

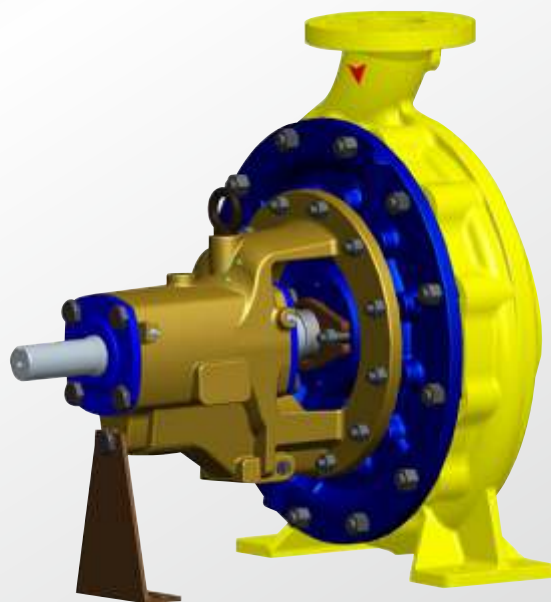

Enriching Lives

Instruction on installation,  
Operation & Maintenance for  
Kirloskar Pump Type - GK



**KIRLOSKAR BROTHERS LIMITED**

Established 1888

A Kirloskar Group Company

**KIRLOSKAR BROTHERS LIMITED**  
“Yamuna” S.No.98/3 to 7, Baner, Pune 41104

## **WARRANTY**

We warrant that the pump supplied from us is free from defective material and faulty workmanship. This warranty holds good for a period of 12 months from the date of commissioning the equipment or 18 months from the date of dispatch from our factory, whichever is earlier. Our liability in respect of any complaint is limited to replacing part/parts free of charge ex-works or repairs of the defective part/parts only to the extent that such replacement / repairs are attributable or arise solely from faulty workmanship or defective material.

This warranty holds good only for the products manufactured by us.

**KIRLOSKAR BROTHERS LIMITED**

# Table of contents

Sr. No. Page No.	Description	
1.0	General	04
2.0	Safety Instructions	05
3.0	Equipment Schedule	09
4.0	Operation	12
5.0	Maintenance Manual	14
5.1	Maintenance EHS instructions	14
5.2	General maintenance documents	14
5.3	Overhauling	14
5.3.1	Dismantling	15
5.3.2	Reassembly	18
5.4	Maintenance Tools required	19
5.5	Preventive Maintenance	19
5.5.1	Daily Checks	19
5.5.2	Periodical Checks	19
5.5.3	Annual Checks	20
5.5.4	Mechanical Seal in Pumps	20
5.6	Corrective Maintenance	21
6.0	Technical Data	21
6.1	Direction of Rotation	21
6.2	Bearing Details	21
6.3	Bearing Lubrication	21
6.4.1	Stuffing Box Sealing	22
6.4.2	Stuffing Box packing specification	22
6.4.3	Stuffing Box Packing & Lantern Ring	22
6.4.4	Gaskets, O-rings & Wear Ring details	23
6.4.5	Interchangeability Chart of Components	26
6.4.6	Recommended Spare Parts	29
7.0	Part Description and Sectional Drawings	30
8.0	Exploded View	36
9.0	General Outline Dimensions	37
10.0	Cut section View	39



## 1.0 GENERAL:

1.1 'KIRLOSKAR' make GK series pumps are of back pull out design which enables to remove the rotating unit of pump for inspection and repairs without disturbing suction and delivery pipe connections.

1.2 The booklet covers instructions for installation, operation & maintenance of following models of GK Pumps:

GK UNIT – 30	GK UNIT – 40	GK UNIT – 50
GK32/13A	GK40/26B	GK65/32B , 65/32BF
GK32/13B	GK50/26 B	GK80/32B , 80/32BF
GK32/16	GK50/32A	GK80/40B , 80/40BF
GK32/20A	GK65/16B	GK100/26B
GK32/20B	GK65/20B	GK100/32B
GK40/1 3	GK65/26A	GK100/40A , 100/40AF
GK40/16	GK65/26B	GK100/40B , 100/40BF
GK40/20A	GK80/16A	GK125/26A
GK40/20B	GK80/20A	GK125/32A
GK50/13	GK80/26A	GK125/32B
GK50/16A	GK100/20A	
GK50/20A		
GK65/13A		

### Applications:

GK pumps are mainly used for clean and clear liquids which are free from suspended solids/particles. Few of the applications are as below:

Water supply, Sprinkling, Air conditioning, Industrial water, Swimming pool water, Hot water, Fire fighting, Irrigation, Drinking water/Potable water, Cooling water, Condensate, Clear juice.

### 1.3 Nameplate information:

Every pump has the following nameplate fitted to bearing housing (2400000) provided with necessary identification of the pump and its specific hydraulic characteristics. The nameplate must not be removed. Loss of this plate could make identification impossible. This in turn could affect safety and cause difficulty in obtaining spare parts. Such accidental loss or damage if occur, contact KBL immediately.



Enriching Lives

PUMP TYPE	<input type="text"/>	 Enriching Lives
PUMP NO.	<input type="text"/>	
O/A NO.	<input type="text"/>	
TOTAL HEAD	<input type="text"/> m MFG. <input type="text"/>	
DISCHARGE	<input type="text"/> m <sup>3</sup> /hr	
PUMP INPUT	<input type="text"/> kW	SPEED <input type="text"/> rpm
IMP. DIA. mm	<input type="text"/>	MAT. CODE <input type="text"/>
MEI > <input type="text"/>	MEI = <input type="text"/>	SIZE <input type="text"/> mm
RECOMMENDED PRIME MOVER RATING	<input type="text"/> kW	
WARNING: PUMP SHOULD NOT BE RUN BELOW/ABOVE <input type="text"/> m TOTAL HEAD		
REGD. USERS - <input type="text"/> m TOTAL HEAD		
<b>KIRLOSKAR BROTHERS LIMITED</b>		
UDYOG BHAVAN, PUNE-411002, (INDIA), WORKS- KIRLOSKARVADI.		

1.4 Pumps when properly installed & given due care in operation & maintenance should operate satisfactorily for a long period.

1.5 When the pump is received, sometime before the actual use of pump, it should be inspected & located in dry place. The shaft should be rotated once in a month to prevent pitting of bearing surfaces.

## 2.0 Safety Instructions:

### 2.1 General Information

Before performing any actions detailed within this instruction, the site Health and Safety instructions and the instructions in this document shall be read and fully understood.

Whenever the equipment is operated, maintained or used in any way, the procedures detailed within these instructions shall be followed. The pump supplied by Kirloskar Brothers Limited (KBL) has been designed with safety in mind; where hazards cannot be eliminated, the risk has been minimized by the use of guards and other design features. Some hazards cannot be guarded against and the instructions below **MUST BE COMPLIED WITH** for safe operation. These instructions cannot cover all circumstances. It is the responsibility of the user of the equipment for maintaining safe working practices at all times. The pumps are supplied with stickers for hazard, caution & safety wherever these are applicable.

2.2.1 Within the manual, safety instructions are marked with safety symbols.

Hazard.



This symbol refers to general mechanical aspects of safety.

Hazard.



This symbol refers to electrical safety.



**CAUTION**

This symbol is used to introduce safety instructions whose nonobservance may lead to damage to the machine and its functions.

- 2.1.2 KBL products are designed for installation in designated areas, which are to be kept clean and free of obstructions that may restrict safe access to the controls and maintenance access points.
- 2.1.3 Access to the equipment should be restricted to the personnel responsible for installation, operation and maintenance and they must be qualified, adequately trained and supplied with the appropriate tools for their respective tasks.
- 2.1.4 This product must be serviced by qualified personnel who are familiar with the design and operation of this product and the system with the essential safety aspects involved.
- 2.1.5 KBL firmly insists that all personnel responsible for installation, operation and maintenance of the equipment must read the manual before any work is done.
- 2.1.6 Our guarantee will be valid only if the installation, operation, maintenance and repairs of this pump are carried out in accordance with these instructions. The plant operator is to make sure that the contents of these instructions are fully understood by the operating personnel. During operation, periodic inspections should be made to assure safe operation under the prevailing conditions.
- 2.1.7 Ear defenders should be worn where the specified equipment noise level exceeds locally defined safe levels. Safety glasses or goggles should be worn where working with pressurized systems and hazardous substances. Other personal protection equipment must be worn where local rules apply.
- 2.1.8 Any modification may be made to the product only after consultation with the manufacturer. Using spare parts and accessories authorized by the manufacturer is a relevant safety aspect. Only genuine spare parts which are in accordance with the original delivery (in the parts list) are to be used.
- 2.2 **CAUTION** DO NOT wear loose or frayed clothing or jewellery, which could catch on the controls or become trapped in the equipment.
- 2.3 Operation of the equipment for the application other than for which it is supplied can increase the risk from hazards. Please consult KBL before making such change in the application of the equipment.
- 2.4 Improper installation, operation and maintenance of the product supplied by KBL could result in injury or death.
- 2.5 Within the manual, safety instructions are marked with safety symbols.



## 2.6 Transport Handling and Storage Instructions:

### 2.6.1 Transport

Pumps are dispatched in duly assembled condition. Lubricating oil in the bearing housing is drained prior to dispatch of pump. Pumps are protected against corrosion and packed for transport by normal road, rail and sea carriers.

### 2.6.2 Handling



#### Crushing Hazard.

When lifting the pump or pump set, use lifting equipment having a safe working load rating suitable for the weight specified. Use suitable slings for lifting the pump which is not provided with lifting points.

The use of suitable forklift truck and four chain crane sling equipment is recommended but locally approved equipment rating may be used. Pump should be slung as shown.

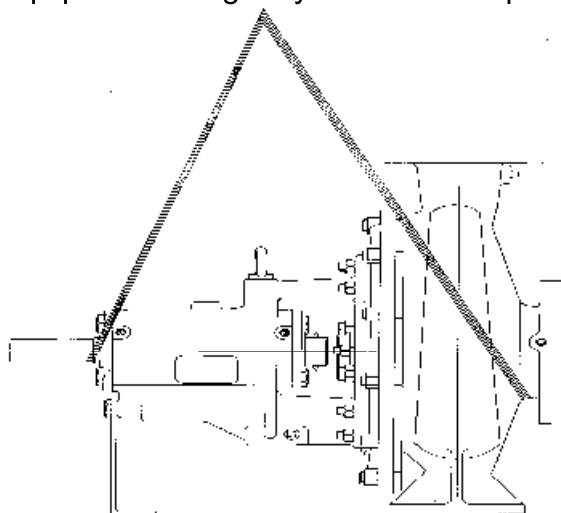

Pump set must be lifted from the lifting holes provided using suitable four chain lifting equipment.

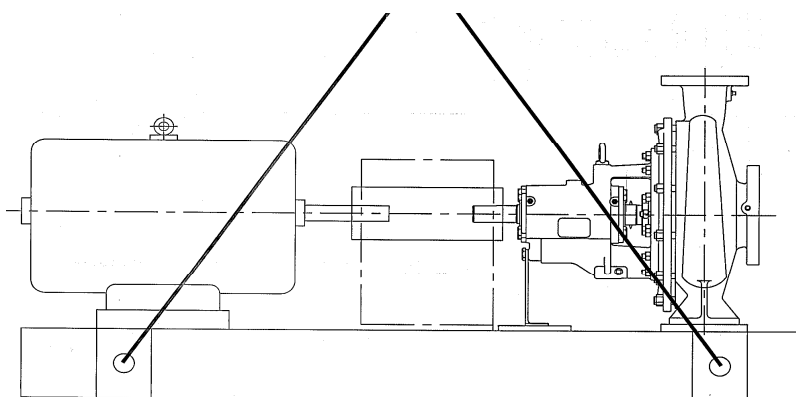



## 2.6.3 Storage:

### 2.6.3.1 Temporary Storage for up to six weeks.

If the pump unit is not to be used immediately it should be stored carefully in a horizontal position, in a sheltered, dry location. Additional rust preventive should be applied to all unpainted carbon steel or cast-iron parts and should not be removed until final installation.

### 2.6.3.2 Long Term Storage.

If the pump is not to be installed and operated soon after arrival, store it in a clean, dry place, having slow, moderate changes in ambient temperature. Step should be taken to protect the pump from moisture, dust, dirt, and foreign bodies. It is recommended that the following precautions to be taken:

- a) Ensure that the bearings are packed with the recommended grease, to prevent moisture from entering around the shaft.
- b) Remove the glands, packings and lantern rings from the stuffing box if the pump is equipped in this manner. If the pump is equipped with mechanical seal, dismantle and coat the seal with light oil.
- c) Ensure that suction and discharge branches of the pump and all other openings are covered with cardboard, wood or masking tape to prevent foreign objects entering the pump.
- d) If the pump is to be stored where there is no protective covering, it is advisable to cover the unit with a tarpaulin or other suitable covering.
- e) The pump shaft should be manually rotated periodically to prevent pitting of the bearing surfaces due to moisture.



Shearing Hazard.

Do NOT place fingers or hands, etc., into the suction or discharge pipe outlets and do NOT touch impeller, if rotated this may cause severe injury.

Fill the bearing housing with recommended grease to ensure that the shaft and bearings remain rust free.

### 2.6.3.3 Exposed or Extreme Conditions Storage.

For exposed storage or extreme variants in atmospheric or environmental conditions, please refer to KBL for special storage instructions to suit the conditions acceptable.

## 2.7 Environmental safety

Always keep the station clean to avoid and/or discover emissions.

Waste and emissions regulations :

Observe these safety regulations regarding waste and emissions:

- Appropriately dispose of all waste.





- Handle and dispose of the processed liquid in compliance with applicable environmental regulations.
- Clean up all spills in accordance with safety and environmental procedures.
- Report all environmental emissions to the appropriate authorities.

#### Electrical installation

For electrical installation recycling requirements, consult your local electric utility.

#### Recycling guidelines

Always follow local laws and regulations regarding recycling.

### 3.0 Equipment Schedule:

#### 3.1 Installation:

3.1.1 For location, preparing foundation, installation, alignment, piping, general maintenance, trouble shooting, etc., the instructions given in our publication - 'GENERAL INSTRUCTIONS FOR INSTALLATION, OPERATION AND MAINTENANCE OF KIRLOSKAR CENTRIFUGAL PUMPS' which is also printed along this booklet must be followed very carefully.

#### 3.1.2 MOUNTING AND ALIGNMENT

A spacer type flexible coupling is used to connect pump shaft to the driver. By using spacer type of coupling, the complete rotating unit can be removed from the volute without removing pump casing or rotor and without disconnecting piping connections. This also avoids any realignment of pump and motor after re-assembly of rotating unit.

#### 3.1.3 ALIGNMENT

ALWAYS REMEMBER "A FLEXIBLE COUPLING IS NOT A UNIVERSAL JOINT".

Correct alignment is essential for the smooth operation of the pump. There are two types of misalignment between the pump shaft and the drive shaft, which are:

- 1) Angular misalignment – Shaft with axis concentric, but not parallel. Maximum allowable misalignment is 1°.

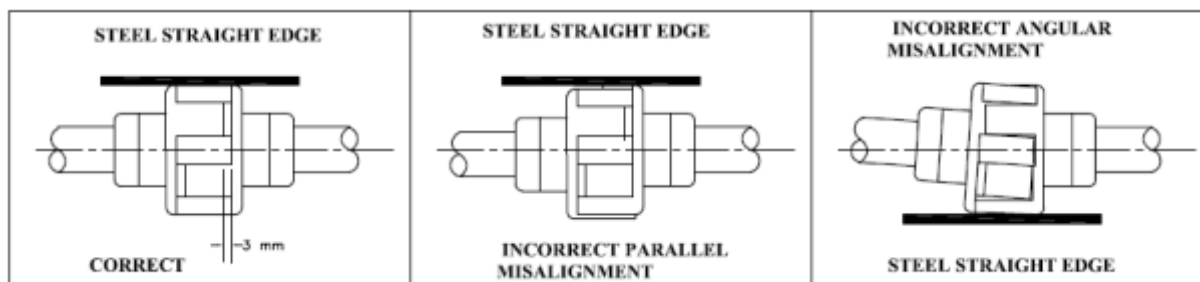

- 2) Parallel misalignment – Shaft with axis parallel, but not concentric.



This misalignment is checked by using a straight edge as shown in figure given above. Before commissioning the pump set, please ensure:

- 3) The pipe connections are flushed and tightened properly.
- 4) Alignment is proper.
- 5) Auxiliary piping connections such as sealing connections, cooling connections, etc., are made. Details of sealing liquid are given in our supply order.

#### FACTORS THAT MAY DISTURB ALIGNMENT

The unit should be periodically checked for alignment. If the unit does not stay in line after being properly installed, the following are possible reasons:

- a) Setting, Seasoning of the foundation.
- b) Pipe strains, distorting or shifting of the machines.
- c) Wear of the bearings.

3.1.4 Before commissioning the pump set, please ensure:

- A. The pipe connections are flushed and tightened properly.
- B. Alignment is proper.
- C. Auxiliary piping connections such as sealing connections, cooling connections, etc., are made.
- D. External connection to the pump if applicable, must be made after installation and before commissioning of pump.

Following tapings are provided on Pump Casing, Suction Cover and bearing housing:

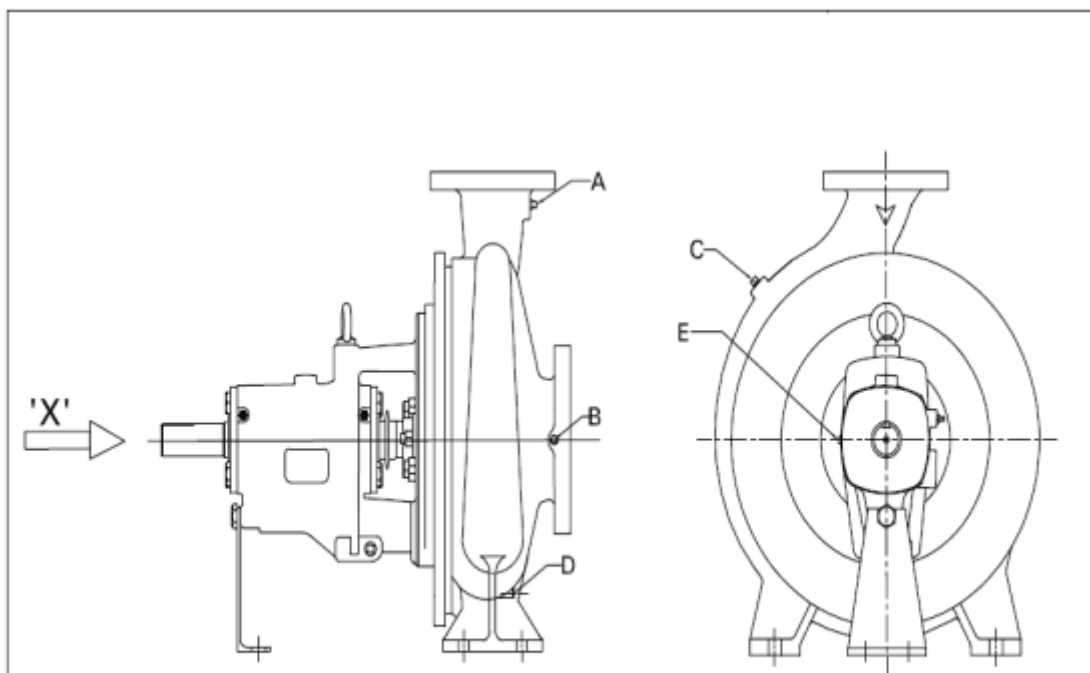

SR. NO.	CODE OF PIPE CONN.	DESCRIPTION	SIZE	CTIONS
			GK-50	
			BSP	
1	A	Gauge Connection Discharge Side	1/4	
2	B	Suction Gauge\ Vacuum Equalising conn.	1/4	
3	C	Flushing\Sealing conn. from Pump Casing	1/4	
4	D	Pump Casing Drain	1/2	
5	E	Stuffing box Sealing Inlet	1/4	

Note: 1) ALL TAPINGS ARE IN INCHES AND LOCATION OF CONNECTIONS ARE SPECIFIED LOOKING FROM ARROW 'X'.



#### 4.0 OPERATION:

##### 4.1 EQUIPMENT DESCRIPTION:

End suction centrifugal pump type GK is from KBL manufactured pump series which dimensionally conforms to ISO 5199 or EN 22858. The mechanical assembly comprises a rigid shaft, supported on deep groove ball bearings with a double shrouded impeller mounted in a removable bearing housing assembly. This is attached to an end suction volute casing fitted with wear rings and back vanes. The bearing housing, shaft and impeller assembly can be withdrawn from the volute for maintenance without disconnection of pipe work.

The discharge branch is positioned vertically upwards while suction branch is horizontal and is at 90° to discharge nozzle. An additional mounting foot is fitted at the outer bearing position for stability.

The complete assembly is of rigid construction, being intended for mounting on suitable base plate with electric motor. A suitable coupling is provided to transmit the rotational drive between pump and motor. A spacer coupling must be used to allow the removal of the pump rotating assembly without disconnecting suction pipe, discharge pipe and motor.

A mechanical seal is used to seal the leakage of pumped liquid across the shaft. Mechanical seal is optional supply.

##### 4.2 EQUIPMENT OPERATION:

###### 4.2.1 Before starting the pump check the following:

- 1) The pump rotates freely by hand.
- 2) Fill in the grease for bearing, if not done earlier. The bearings are packed with grease initially at the factory. However, if the pump is stored for a longer time it is necessary to refill the grease in bearings.
- 3) The direction of rotation of driver. It should correspond to the direction of rotation of pump.
- 4) The pump casing and the suction pipeline is fully primed with the liquid.
- 5) Valve on delivery side is closed.
- 6) The cock for pressure gauge connection is closed.

###### 4.2.2 Starting the pump.

- 1) Start the pump. Let the prime mover pickup its full speed.
- 2) Open the valve on delivery line gradually.
- 3) Regulate the required flow by adjusting the delivery valve.
- 4) Open the cock for pressure gauge connection.

###### 4.2.3 During running the pump check the following things and regulate if needed.

- 1) The pump is running smooth.
- 2) The flow of sealing liquid [if external liquid is provided for sealing purpose] is uninterrupted.
- 3) Leakage through stuffing box is normal. There should be 60-80 drops per minute.



- 4) The bearings are not getting abnormally hot.
- 5) Head and capacity developed by the pump is as specified.
- 6) Power consumption is within limit.
- 7) Ensure that there is no mechanical friction in the pipe.
- 8) Stop the pump immediately, if any defects are detected. Do not start the pump unless the defects are rectified.

#### 4.2.4 During stopping the pump

- 1) Close the valve on the delivery line.
- 2) Stop the motor.
- 3) Close the cooling water and sealing liquid connections.
- 4) If the pump is not required to be operated for a long time, drain the casing completely. If the pump is required to be stored for a long time, the bearing housing should be dried internally with hot air and should be flushed with moisture free protective such as light oil or kerosene.

Be aware of the hazards relating to the pumped fluid, especially the danger from inhalation of noxious and toxic gases, skin and eye contact or penetration.



#### Electric Shock and Accidental Starting Hazard:

Isolate the equipment before any maintenance work is done. Switch off the mains supply, remove fuses, apply lockouts where applicable and affix suitable isolation warning signs to prevent inadvertent re-connection.

In order to avoid the possibility of maintenance personnel inhaling dangerous fumes or vapours, it is recommended that maintenance work be carried out away from the pump location by removal of the rotating unit assembly to a suitable maintenance area.

Failing to follow right shop practices during equipment operation will result into failure of product & in turn product warranty gets void.



## 5.0 MAINTENANCE MANUAL:

### 5.1 MAINTENANCE EHS INSTRUCTIONS:

Following hazards may arise during maintenance work.



Fluid Pressure Jet Hazards.



Check and ensure that the pump operates at below the maximum Working Pressure specified.

Before attempting any maintenance on a pump, ensure that the unit is safe to work on. The pump must be flushed thoroughly with suitable cleaner to purge away any of the product left in the pump components. The plant operator should carry this out and a certificate of cleanliness obtained before starting work. To avoid any risk to health it is also advisable to wear protective clothing as recommended by the site safety officer, especially when removing old packing that may be contaminated.

### 5.2 GENERAL MAINTENANCE DOCUMENTS

Maintenance documents:

- a) Pump Sectional assembly drawing with part list
- b) Pump Outline dimension drawing
- c) Mechanical seal assembly / GA drawing
- d) Foundation plan drawing
- e) Pump data sheet

Specific Maintenance data:

### 5.3 Overhauling:

With normal daily operating spell, the pump will be due for overhaul after about 5000 working hours. This work should be done by skilled personnel.

### Procedure for dismantling and re-assembly

While dismantling and re-assembling, the cross-sectional assembly drawing and specification part list should be referred.

#### 5.3.1 DISMANTLING

Follow the following simple steps to dismantle the pump.

- 5.3.1.1 Isolate power supply to motor.
- 5.3.1.2 Shut off valves controlling flow to and from the pump.
- 5.3.1.3 Drain the liquid from pump by removing the drain plug or open the pump casing drain cock.
- 5.3.1.4 We recommend matching the punch mark of the coupling halves.



- 5.3.1.5 In case of the pumps with spacer type flexible couplings, disconnect coupling (pump half and motor half) from the coupling spacer and remove coupling spacer. In case of ordinary flexible couplings, remove the motor from the base.
- 5.3.1.6 Remove the support foot (25100) hold down bolts.
- 5.3.1.7 Adjust string or chain tension to support the weight of the back pull out assembly.
- 5.3.1.8 Remove the hexagonal nuts (58100) from casing stud holding the casing cover (22000) to pump casing (10500).
- 5.3.1.9 Screw the release bolts provided in casing cover. Turn bolts evenly through a quarter turn at both sides.
- 5.3.1.10 Slightly pull out the driving unit till impeller (15100) clears the pump casing (10500).

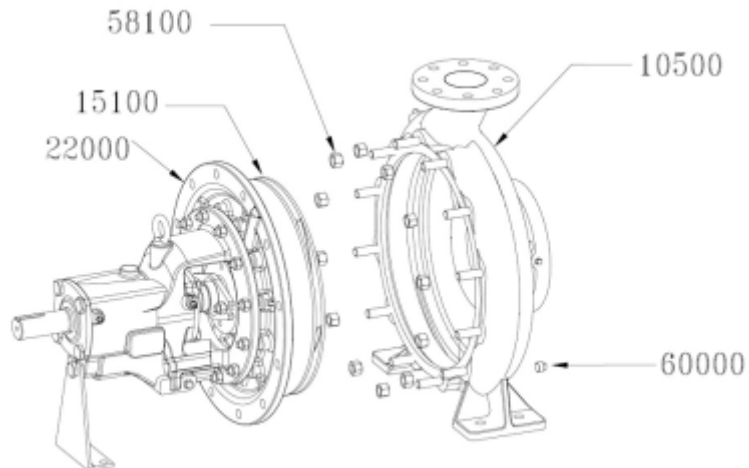

- 5.3.1.11 Place this rotating unit on a table or clear place for further dismantling.
- 5.3.1.12 Remove casing gasket (51100).
- 5.3.1.13 Unscrew the impeller screw (66900) & remove impeller screw gasket (51500).
- 5.3.1.14 Take out the impeller (15100) from pump shaft (18000).

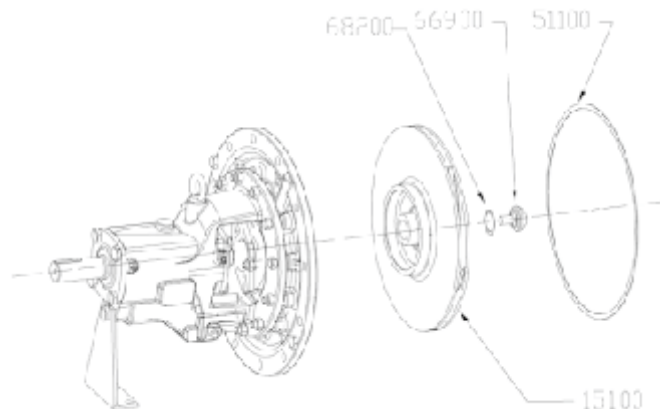

### 5.3.1.15 Removal of stuffing box with gland packing:

For this, following steps should be taken: Remove the gland (22900) by taking out bolts used for clamping of the gland. Take out the casing cover (22000) along with gland packing (43000) and lantern ring (22700).

- 1) Remove the gland packing rings (43000) and lantern ring (22700).
- 2) Remove the shaft sleeve (31000) with 'O'ring (52500).
- 3) Remove the liquid deflector (23600).

### 5.3.1.16 Remove the nuts holding the pump casing/casing cover (10500/22000) and bearing housing (24000).

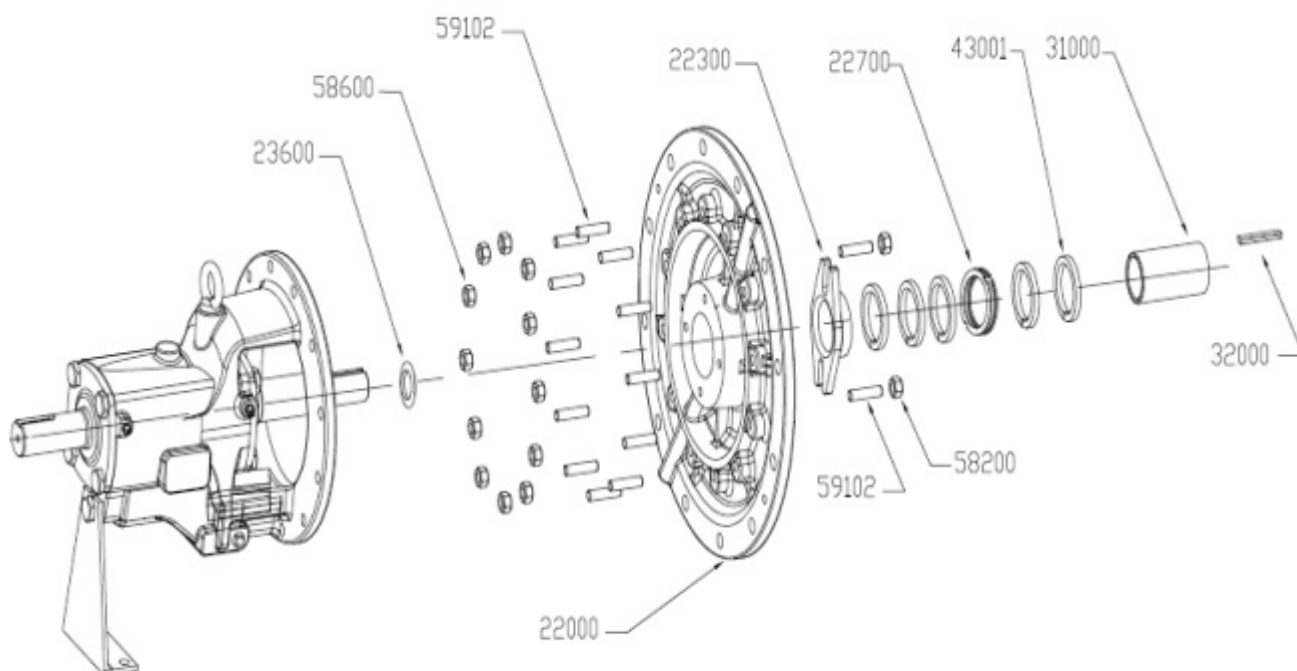

### 5.3.1.17 Take out bearing housing (24000).

### 5.3.1.18 Remove pump half coupling after unscrewing grub screw.

**CAUTION**

Coupling half should be removed with the help of suitable extraction device. To avoid damage to the bearings, coupling half should not be knocked out of shaft.

### 5.3.1.19 Take out coupling key (32100).

### 5.3.1.20 Loosen the bolts holding bearing cover (27000) (driving end). Remove carefully bearing cover.

### 5.3.1.21 Force shaft (18000) carefully in the direction of driving end. After DE side bearing come out along with shaft unclamp the circlip (48500). Now pull shaft, it will come out along with the bearings & circlip.



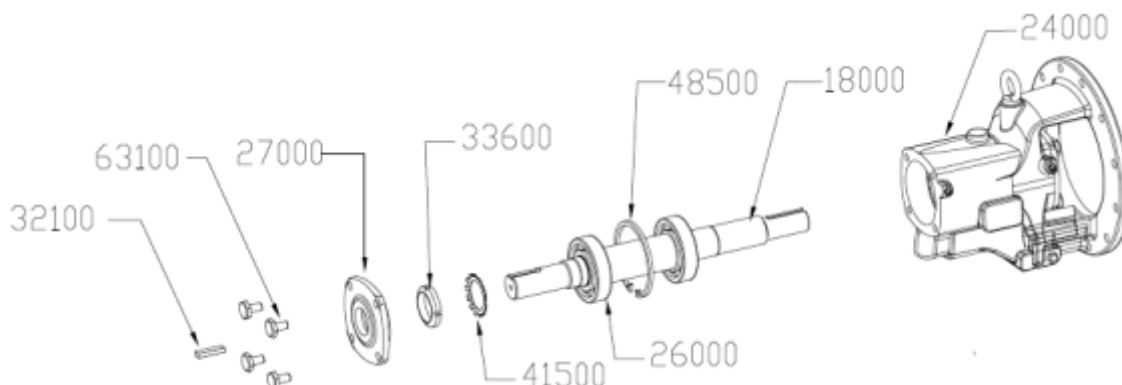

To dismantle shaft seal arrangement:

- a) Clamped casing cover units – The following pumps have this type of construction.

100/26B	32/13B	65/13A
125/26A	40/13	65/16B
32/13A	50/13	80/16A

- b) Soft packed pumps – Remove gland nuts and withdraw gland (22300). Unpack stuffing box.  
 c) Remove impeller (15100). Remove casing cover (22000) from the bearing housing. Draw shaft sleeve (31000) off end of shaft (18000).  
 d) Bolted casing cover units – The following pumps have this type of construction.

65/32B, 65/32BF	80/40B, 80/40BF	50/16A	50/20A	50/26B
80/32B, 80/32BF	100/40A, 100/40AF	32/20A	65/20B	65/26A
100/32B	100/40B, 100/40BF	32/20B	80/20A	65/26B
125/32A	32/16	40/20A	100/20A	80/26A
125/32B	40/16	40/20B	40/26B	50/32A

- e) Soft packed pumps – Remove gland nuts and with draw gland (22300). Unpack stuffing box. Remove impeller (15100) as above. Remove casing cover (22000) from the bearing housing. Draw shaft sleeve (31000) off end of shaft (18000).

5.3.1.22 Remove screws for bearing cover. Draw DE bearing cover (27000) out of bearing housing (24000) and off shaft.

5.3.1.23 Take out the driving end bearing (26000) with the help of puller.

**CAUTION**

- 1) Push the sleeve on arbour press with uniform pressure.
- 2) Steps 5.2.1.22 to 5.2.1.24 are to be followed only if bearings are damaged and to be replaced.

5.3.1.24 The pump shaft (18000) can now be carefully driven with its bearing housing (24000), in the direction of the drive end, for the DE bearing (26000) to just clear the bearing housing (24000).

5.3.1.25 The NDE bearing (26000) can be pressed through the end of the bearing housing. Care must be taken to ensure the bearing passes centrally through the bore of bearing housing.

5.3.1.26 NDE bearing (26000) can be pressed off impeller end of shaft (18000).



5.3.1.27 DE bearing (26000) can be pressed off drive end of shaft (18000), after the careful removal of the shaft circlip ring.

During and after dismantling:

1. Wash all old grease from ball bearings and housings with kerosene or white spirit and thoroughly dry bearings. Renew them if they do not rotate smoothly with no sign of jamming and freely but with slackness, or if running surfaces of balls show any deterioration. Coat bearing with rust preventive oil and wrap in greaseproof paper.
2. Mount shaft on between point centres or on rollers and place stem of dial indicator in contact with the shaft. Set the indicator dial at zero and turn the shaft slowly by hand. Reading at any point must not vary more than 0.05mm.
3. Examine shaft sleeve for wear and check for true. It is important that the surfaces of the sleeve, which run in the stuffing box, against soft packing, are concentric and not scored or damaged. If true of shaft is satisfactory, remount the shaft as in 2 above, but with the sleeve fitted and check for true with dial indicator. Indicator readings must not vary more than 0.08mm.

5.3.2 Re-assembly:

This procedure covers re-assembly of pump after complete dismantling of the pump. Before re-assembly, all the parts should be thoroughly cleaned in kerosene, petrol or benzene to remove the dust, rust, etc. After cleaning, the necessary parts should be replaced.

5.3.2.1 The assembly of the pump unit is carried out in the reverse order of dismantling .

**CAUTION**

Use arbour press while fitting the bearings. However, it is recommended that bearings should be heated in oil bath at temperature 70 to 80°C and then fitted. (If hot oil bath is not available then ARBOUR PRESS must be used).

Use gloves while fitting bearings from hot oil bath.

- a) Slide inboard ball bearing on shaft by hand, make sure that it is square with shaft. Press evenly the inner race of the bearing until bearing is seated firmly against the shaft shoulder.
- b) Do not use hammer to fit the bearings. Do not damage the shaft surface especially where it is in contact with oil seal.

5.3.2.2 If the shaft is to be fitted with new bearing, it is necessary to heat to a temperature of 80 ° C. The bearings must locate against the shoulders of the shaft.

5.3.2.3 Prior to assembly of bearings, they should be packed with clean, good quality lubricating grease. DE and NDE bearing covers (27000/27100) should also be lightly packed with grease, before sliding over shaft end, locating and securing to bearing housing (24000).

5.4 Maintenance Tools required:

No special tools are required for dismantling and reassembling. Toolbox containing a general set of tools such as different size ring spanners, torque



wrenches, open ended spanners, light ball peen hammer, wooden mallet, various sizes Allen keys, etc., serves the purpose. It is important to ensure that the suitable lifting equipment is available and that the work is carried out in clean area.

## 5.5 PREVENTIVE MAINTENANCE

Preventive maintenance schedule is the periodical checks and precautions by which possibilities of failures and breakdowns are minimized.

### 5.5.1 Daily Checks:

- 5.5.1.1 Hourly record of suction and delivery pressure, discharge quantity, input to the pump driver should be maintained.
- 5.5.1.2 Bearing temperature, stuffing box leakage / stuffing box temperature, this gives an idea of mechanical performance of the pump.
- 5.5.1.3 Noise and vibrations are the first signs of impending troubles like cavitation, air lock, bearing failure, choking of impeller or casing and such other operating troubles. The pump performance should the refore be checked for noise and vibrations.

### 5.5.2 Periodical Checks :

- 5.5.2.1 The temperature of the bearing should be measured by thermometer. Safe maximum working temperature of the bearing is 80° C.
- 5.5.2.2 The lubricants of the bearing should be checked. The lubricant might get contaminated with foreign material or get blackened due to overheating. In such cases, bearings should be flushed and charged with fresh lubricants.
- 5.5.2.3 Check for the stuffing box leakage.
- 5.5.2.4 The alignment of the pump unit should be checked. Due to operational vibrations, atmospheric temperature or stress induced by the weight of the piping, the alignment may get disturbed.
- 5.5.2.5 Sufficient quantity of suitable type of lubricant should be ready for daily and emergency use.
- 5.5.2.6 Calibrate the measuring instrument.

### 5.5.3 Annual Checks:

- 5.5.3.1 The pump should be overhauled completely to check the clearance and to replace worn-out parts. Clearance between impeller and casing rings, shaft sleeves and throat bush, lantern ring and shaft sleeve, etc., are very important. The bearings should be cleaned thoroughly and lubricated.
- 5.5.3.2 The effects of liquid handled on pump components should be checked. If abnormal corrosion, erosion is observed, the component should be replaced with that of suitable material.



- 5.5.3.3 The auxiliary pipelines and functioning of the auxiliary system should be checked. The main pipe also should be checked for scaling, leakage etc.
- 5.5.3.4 The measuring instruments, gauges, etc., should be recalibrated.
- 5.5.3.5 Full running test may be carried out to check whether there is any fault in the performance, in comparison with original performance.
- 5.5.3.6 Piping supports should be checked so that the pipes do not induce unwanted stresses on the pump.

In case failure to check above points & maintain proper records/precautions of checks by customer/user, KBL warranty gets void.

#### 5.5.4 Mechanical Seal in Pumps :

The mechanical seal is a precision product having been subjected to quality control throughout all stages of manufacture. The seals are designed to accommodate reasonable tolerances in the equipment, however in order to obtain the maximum life with trouble free performance, the equipment should be adequately maintained.

When mechanical seal is functioning satisfactorily without any leakage, the preventive maintenance is not advocated. If leakage occurs, a thorough check up is needed. While fitting the mechanical seals in the pump initially by KBL, due care is taken for its proper fitment.

Like other parts in the equipment the mechanical seals are subject to wear at the mating faces of the rotating and stationary ring. The rate of wear will differ with the operating conditions and various other factors such as lubricating property of the liquid pumped, the presence of impurities in liquid and other operating conditions. In view of this no firm recommendations can be given for renewal of seal rings / complete seals.

The mechanical seal is optional feature and supply will be of unbalanced cartridge type mechanical seal as standard construction for which no further operating length adjustments are required.

Before any action to be taken for cartridge seal removal, **FIRST SLIDE THE SLIDING WASHERS AND ENGAGE THEM IN THE GROOVE ON DRIVE COLLAR FIRMLY.** Remove grub screw of driving collar which is engaged on Shaft / Shaft sleeve.

For fitting cartridge type mechanical seal, always refer mechanical seal drawing Important - While sliding the cartridge assembly, ensure the sleeve slides forward easily to avoid the seals getting over compressed and damaged. Do not give jerks to the assembly, which may damage the mating ring. While sliding the complete assembly do not hammer on the gland/seal cover. Apply synthetic grease or oil on the shaft while sliding the assembly. This will ease the sliding of O-ring. Tighten the mechanical seal cover with casing cover stud & grub screws of drive collar on shaft / shaft sleeve. Then remove **SLIDING WASHER** and check free rotation of drive collar.



## 5.6 CORRECTIVE MAINTENANCE

### PUMP TROUBLE

When investigating trouble with Kirloskar pumps, always remember that pumps have been tested at the factory and are mechanically correct when sent out. Discounting the possibility of damage during transit, most of the trouble in the field is due to faulty installation. Investigation shows that the majority of troubles with centrifugal pumps result from faulty conditions on the suction side.

### BREAK-DOWN-CAUSE-CHECK-POINTS

In case of breakdown we recommend the location of the fault by referring the table for 'Break Down Check Points' given at the end of this manual.

## 6.0 TECHNICAL DATA:

### 6.1 Direction of rotation:

The direction of rotation is clockwise when viewed from driving end.

### 6.2 Bearings:

The shaft is supplied with antifriction ball bearing at driving end and non-driving end. The bearing specifications are given below. The designations of bearings are as per SKF catalogue. However, equivalent bearing in type, capacity and dimensions are also used.

#### BEARING DETAILS:

Driving Unit	Deep groove Ball Bearing size		Bearing life	
	Driving End	Non-Driving End	Within 0.75 to 1.1 BEP zone	Beyond 0.75 to 1.1 BEP zone
30	6306 (1no.)	6306 (1no.)	25,000 hrs.	17,500 hrs.
40	6308 (1no.)	6308 (1no.)	25,000 hrs.	17,500 hrs.
50	6310 (1no.)	6310 (1no.)	25,000 hrs.	17,500 hrs.

Bearing temperature:

a) Maximum allowable temperature of bearings: 80°C

b) Bearing details:

Driving end: SKF Deep groove ball bearing

Non-driving end: Deep groove ball Bearings of SKF or equivalent make and with C3 clearance are used. SKF or equi.



### 6.3 Bearing Lubrication:

6.3.1 Bearings are grease lubricated. Bearings are lubricated during assembly of pump at our factory. The re-greasing should be done after every 2000 hours of running. To recharge the bearing with fresh grease, use a grease gun through the nipples provided. **DO NOT APPLY LUBRICANT WHEN PUMP IS RUNNING.**

6.3.2 Following lubricant grades available in the market are suitable.

#### [A] GREASE:

Details of Grease Lubrication:

MANUFACTURER	SPEED	
	1500 RPM	3000 RPM
INDIAN OIL	SERVOGEM 3	SERVOGEM 2
CALTEX	STARFAX 3	STARFAX 2
HINDUSTAN PETROLEUM	NATRA 3 OR LITHON 3	NATRA 2 OR LITHON 2
SHELL	ALVANIA EP 2	ALVANIA EP 2
EXXON	POLYREX	POLYREX
TEXACO	MULTIFAK EP3	MULTIFAK EP2
CHEVRON	SRI GREASE NLGI 2	SRI GREASE NLGI 2

#### Quantity of Grease:

DRIVING UNIT	QUANTITY APPROX. (gm)
30	15
40	25
50	35

#### Re-greasing intervals:

- 1) 1500 RPM- After 5000 Hrs.
- 2) 3000 RPM- After 4500 Hrs.

### 6.4 Stuffing Box:

#### 6.4.1 Stuffing Box sealing arrangement-

Self liquid sealing is standard supply. External liquid sealing arrangement can be provided on request.

#### 6.4.2 Stuffing Box packing specification-

Champion style 3116 – Graphited cotton greasy packing is used in the pump as a standard supply. However, stuffing box packing suitable for liquid handled is supplied against specific requirements.

#### 6.4.3 Stuffing Box Packing and Lantern Ring –

Please refer to the following chart for stuffing box packing size and position of lantern ring.



UNIT	STUFFING BOX PACKING SIZE [mm]	TOTAL LENGTH OF PACKING [mm]	POSITION FROM IMPELLER L=LANT.RING
50	8	1180	2+L+3
40	10	690	2+L+2
30	8	540	2+L+2

#### 6.4.4 Gaskets, O-rings and Wear Ring details:

##### A) Gasket Details:

As a standard scope pumps are supplied with following gasket and gland packing in materials:

Gasket: Ferrolite NAM 37 or equivalent.

PART DESCRIPTION	GASKET FOR CASING & CASING COVER	GASKET FOR SHAFT SLEEVE	GASKET FOR IMPELLER NUT
PART NO.	51100	51500	68200
GK65/32B, 65/32BF	331D X 348D X 1.5TH	44D X 50D X 1TH	38D X 48D X 1TH
GK80/32B, 80/32BF	330D X 348D X 1TH	44D X 50D X 1TH	38D X 48D X 1TH
GK80/40B, 80/40BF	330D X 348D X 1TH	44D X 50D X 1TH	38D X 48D X 1TH
GK100/32B	330D X 348D X 1TH	44D X 50D X 1TH	38D X 48D X 1TH
GK100/40A, 100/40AF	410D X 430D X 1TH	44D X 50D X 1TH	38D X 48D X 1TH
GK100/40B, 100/40BF	410D X 430D X 1TH	44D X 50D X 1TH	38D X 48D X 1TH
GK100/26B	266D X 286D X 1TH	44D X 50D X 1TH	38D X 48D X 1TH
GK125/32A	330D X 348D X 1TH	44D X 50D X 1TH	38D X 48D X 1TH
GK125/32B	330D X 348D X 1TH	44D X 50D X 1TH	38D X 48D X 1TH
GK125/26A	266D X 286D X 1TH	44D X 50D X 1TH	38D X 48D X 1TH
GK32/13A	141D X 152D X 1TH	20D X 24D X 0.5TH	20D X 28D X 1.5TH
GK32/13B	141D X 152D X 1TH	20D X 24D X 0.5TH	20D X 28D X 1.5TH
GK40/13	141D X 152D X 1TH	20D X 24D X 0.5TH	20D X 28D X 1.5TH
GK50/13	141D X 152D X 1TH	20D X 24D X 0.5TH	20D X 28D X 1.5TH
GK65/13A	141D X 152D X 1TH	20D X 24D X 0.5TH	20D X 28D X 1.5TH
GK32/16	176D X 188D X 1.5TH	20D X 24D X 0.5TH	20D X 28D X 1.5TH
GK40/16	176D X 188D X 1.5TH	20D X 24D X 0.5TH	20D X 28D X 1.5TH
GK50/16A	176D X 188D X 1.5TH	20D X 24D X 0.5TH	20D X 28D X 1.5TH
GK32/20A	216D X 230D X 1.5TH	20D X 24D X 0.5TH	20D X 28D X 1.5TH
GK32/20B	216D X 230D X 1.5TH	20D X 24D X 0.5TH	20D X 28D X 1.5TH
GK40/20A	216D X 230D X 1.5TH	20D X 24D X 0.5TH	20D X 28D X 1.5TH



PART DESCRIPTION	GASKET FOR CASING & CASING COVER	GASKET FOR SHAFT SLEEVE	GASKET FOR IMPELLER NUT
PART NO.	51100	51500	68200
GK40/20B	216D X 230D X 1.5TH	20D X 24D X 0.5TH	20D X 28D X 1.5TH
GK50/20A	216D X 230D X 1.5TH	20D X 24D X 0.5TH	20D X 28D X 1.5TH
GK65/16B	176D X 188D X 1.5TH	28D X 32D X 0.5TH	28D X 38D X 1.5TH
GK80/16A	176D X 188D X 1.5TH	28D X 32D X 0.5TH	28D X 38D X 1.5TH
GK65/20B	216D X 230D X 1.5TH	28D X 32D X 0.5TH	28D X 38D X 1.5TH
GK80/20A	216D X 230D X 1.5TH	28D X 32D X 0.5TH	28D X 38D X 1.5TH
GK100/20A	216D X 230D X 1.5TH	28D X 32D X 0.5TH	28D X 38D X 1.5TH
GK40/26B	266D X 282D X 1.5TH	28D X 32D X 0.5TH	28D X 38D X 1.5TH
GK50/26B	266D X 282D X 1.5TH	28D X 32D X 0.5TH	28D X 38D X 1.5TH
GK65/26A	266D X 282D X 1.5TH	28D X 32D X 0.5TH	28D X 38D X 1.5TH
GK65/26B	266D X 282D X 1.5TH	28D X 32D X 0.5TH	28D X 38D X 1.5TH
GK80/26A	266D X 282D X 1.5TH	28D X 32D X 0.5TH	28D X 38D X 1.5TH
GK50/32A	331D X 348D X 1.5TH	28D X 32D X 0.5TH	28D X 38D X 1.5TH

Note: Against requirement, gland packing and gasket in PTFE can be supplied at extra cost.

B) 'O'-Ring Details:

PART DESCRIPTION	'O' RING FOR SHAFT SLEEVE
PART NO.	52500
UNIT 50	55.15ID X 1.58D
UNIT 40	40.15ID X 1.58D
UNIT 30	30.40ID X 1.58D

C) Wear Ring Details:

MODEL	SUCTION SIDE			DELIVERY SIDE		
	BASIC DIA.	MIN.	MAX.	BASIC DIA.	MIN.	MAX.
GK65/32B, 65/32BF	150	0.443	0.606	150	0.443	0.606
GK80/32B, 80/32BF	180	0.443	0.606	180	0.443	0.606
GK100/32B,	180	0.443	0.606	180	0.443	0.606
GK125/32A	180	0.443	0.606	180	0.443	0.606
GK125/32B	200	0.450	0.622	200	0.450	0.622
GK80/40B, 80/40BF	165	0.443	0.606	180	0.443	0.606
GK100/40A, 100/40AF	165	0.443	0.606	180	0.443	0.606





Enriching Lives

MODEL	SUCTION SIDE			DELIVERY SIDE		
	BASIC DIA.	MIN.	MAX.	BASIC DIA.	MIN.	MAX.
GK100/40B, 100/40BF	180	0.443	0.606	180	0.443	0.606
GK100/26B	195	0.450	0.62	Back Vane		
GK125/26A	195	0.450	0.62	Back Vane		
GK32/13A	80	0.430	0.57	Back Vane		
GK32/13B	80	0.430	0.57	Back Vane		
GK40/13	95	0.336	0.49	Back Vane		
GK50/13	105	0.336	0.49	Back Vane		
GK65/13A	115	0.336	0.49	Back Vane		
GK32/16	90	0.336	0.490	90	0.336	0.490
GK40/16	105	0.336	0.490	105	0.336	0.490
GK50/16A	105	0.336	0.490	105	0.336	0.490
GK32/20A	95	0.436	0.590	95	0.436	0.590
GK32/20B	95	0.436	0.590	95	0.436	0.590
GK40/20A	95	0.436	0.590	95	0.436	0.590
GK40/20B	95	0.436	0.590	95	0.436	0.590
GK50/20A	95	0.436	0.590	95	0.436	0.590
GK65/16B	140	0.443	0.606	140	0.443	0.606
GK80/16A	140	0.443	0.606	140	0.443	0.606
GK65/20B	130	0.443	0.606	155	0.443	0.606
GK80/20A	130	0.443	0.606	155	0.443	0.606
GK100/20A	165	0.443	0.606	155	0.443	0.606
GK40/26B	115	0.436	0.590	115	0.436	0.590
GK50/26B	115	0.436	0.590	115	0.436	0.590
GK65/26A	115	0.436	0.590	115	0.436	0.590
GK65/26B	130	0.443	0.606	130	0.443	0.606
GK80/26A	130	0.443	0.606	130	0.443	0.606
GK50/32A	120	0.436	0.590	120	0.436	0.590



### 6.4.5 INTERCHANGEABILITY CHART OF COMPONENTS

CT1GK007-1

## INTERCHANGEABILITY CHART OF GK PUMP COMPONENTS

PART CODE NO.	PART DESCRIPTION	QTY.PER UNIT	PUMP SIZE									
			DRIVING UNIT 50									
			65/32B 65/32BF	80/32B 80/32BF	100/32B	125/32A	125/32B	80/40B 80/40BF	100/40A 100/40AF	100/40B 100/40BF	100/26B	125/26A
105	PUMP CASING	1	1	2	3	4	5	6	7	8	9	10
151	ENCLOSED IMPELLER	1	1	2	3	3	4	5	6	7	8	8
220	CASING COVER	1	1	2	2	2	3	4	4	4	5	5
190	WEAR RING (SUCTION)	1	1	2	3	2	4	5	6	2	7	7
191	WEAR RING (ST.BOX)	1	1	2	2	2	3	4	4	4	-	-
251	SUPPORT FOOT	1	1	2	2	3	3	3	3	3	1	2
227	LANTERN RING	1	1	1	1	1	1	1	1	1	1	1
310	SHAFT SLEEVE	1	1	1	1	1	1	1	1	1	1	1
223	GLAND	1	1	1	1	1	1	1	1	1	1	1
430	GLAND PACKING	1	1	1	1	1	1	1	1	1	1	1
240	BEARING HOUSING	1	1	1	1	1	1	1	1	1	1	1
270	BEARING COVER (DE)	1	1	1	1	1	1	1	1	1	1	1
271	BEARING COVER (NDE)	1	1	1	1	1	1	1	1	1	1	1
260	BALL BEARING (DE)	1	1	1	1	1	1	1	1	1	1	1
260	BALL BEARING (NDE)	1	1	1	1	1	1	1	1	1	1	1
180	PUMP SHAFT	1	1	1	1	1	1	1	1	1	1	1
669	IMPELLER SCREW	1	1	1	1	1	1	1	1	1	1	1
236	LIQUID DEFLECTOR	1	1	1	1	1	1	1	1	1	1	1
320	KEY FOR IMPELLER	1	1	1	1	1	1	1	1	1	1	1
321	KEY FOR COUPLING	1	1	1	1	1	1	1	1	1	1	1



CT1GK008-0

INTERCHANGEABILITY CHART OF GK PUMP COMPONENTS

PART CODE NO.	PART DESCRIPTION	QTY. PER UNIT	PUMP SIZE												
			DRIVING UNIT 30												
			32/13A	32/13B	40/13	50/13	65/13A	32/16	40/16	50/16A	32/20A	32/20B	40/20A	40/20B	50/20A
105	PUMP CASING	1	1	2	3	4	5	6	7	8	9	9	10	11	12
151	ENCLOSED IMPELLER	1	1	2	3	4	5	6	7	8	9	10	10	11	11
220	CASING COVER	1	1	1	1	1	1	2	2	3	4	4	4	4	5
190	WEAR RING (SUCTION)	1	1	1	2	3	4	5	2	2	2	2	2	2	2
191	WEAR RING (ST.BOX)	1	-	-	-	-	-	1	2	2	2	2	2	2	2
251	SUPPORT FOOT	1	1	1	1	2	3	2	2	3	3	3	3	3	3
227	LANTERN RING	1	1	1	1	1	1	1	1	1	1	1	1	1	1
310	SHAFT SLEEVE	1	1	1	1	1	1	1	1	1	1	1	1	1	1
223	GLAND	1	1	1	1	1	1	1	1	1	1	1	1	1	1
430	GLAND PACKING	1	1	1	1	1	1	1	1	1	1	1	1	1	1
240	BEARING HOUSING	1	1	1	1	1	1	1	1	1	1	1	1	1	1
270	BEARING COVER (DE)	1	1	1	1	1	1	1	1	1	1	1	1	1	1
271	BEARING COVER (NDE)	1	1	1	1	1	1	1	1	1	1	1	1	1	1
260	BALL BEARING (DE)	1	1	1	1	1	1	1	1	1	1	1	1	1	1
260	BALL BEARING (NDE)	1	1	1	1	1	1	1	1	1	1	1	1	1	1
180	PUMP SHAFT	1	1	1	1	1	1	1	1	1	1	1	1	1	1
330	IMPELLER NUT	1	1	1	1	1	1	1	1	1	1	1	1	1	1
236	LIQUID DEFLECTOR	1	1	1	1	1	1	1	1	1	1	1	1	1	1
320	KEY FOR IMPELLER	1	1	1	1	1	1	1	1	1	1	1	1	1	1
321	KEY FOR COUPLING	1	1	1	1	1	1	1	1	1	1	1	1	1	1



CT1GK009-0

## INTERCHANGEABILITY CHART OF GK PUMP COMPONENTS

PART CODE NO.	PART DESCRIPTION	QTY./PER UNIT	PUMP SIZE										
			DRIVING UNIT 40										
			65/16B	80/16A	65/20B	80/20A	100/20A	40/26B	50/26B	65/26A	65/26B	80/26A	50/32A
105	PUMP CASING	1	1	2	3	4	5	6	7	8	9	10	11
151	ENCLOSED IMPELLER	1	1	1	2	2	3	4	5	5	6	7	8
220	CASING COVER	1	1	1	2	2	2	3	3	3	4	4	5
190	WEAR RING (SUCTION)	1	1	1	2	2	3	4	4	4	5	6	7
191	WEAR RING (ST.BOX)	1	1	1	2	2	3	4	4	4	5	6	7
251	SUPPORT FOOT	1	1	2	2	2	3	4	4	5	3	6	7
227	LANTERN RING	1	1	1	1	1	1	1	1	1	1	1	1
310	SHAFT SLEEVE	1	1	1	1	1	1	1	1	1	1	1	1
223	GLAND	1	1	1	1	1	1	1	1	1	1	1	1
430	GLAND PACKING	1	1	1	1	1	1	1	1	1	1	1	1
240	BEARING HOUSING	1	1	1	1	1	1	1	1	1	1	1	1
270	BEARING COVER (DE)	1	1	1	1	1	1	1	1	1	1	1	1
271	BEARING COVER (NDE)	1	1	1	1	1	1	1	1	1	1	1	1
260	BALL BEARING (DE)	1	1	1	1	1	1	1	1	1	1	1	1
260	BALL BEARING (NDE)	1	1	1	1	1	1	1	1	1	1	1	1
180	PUMP SHAFT	1	1	1	1	1	1	1	1	1	1	1	1
330	IMPELLER NUT	1	1	1	1	1	1	1	1	1	1	1	1
236	LIQUID DEFLECTOR	1	1	1	1	1	1	1	1	1	1	1	1
320	KEY FOR IMPELLER	1	1	1	1	1	1	1	1	1	1	1	1
321	KEY FOR COUPLING	1	1	1	1	1	1	1	1	1	1	1	1



## 6.4.6 RECOMMENDED SPARE PARTS:

Item No.	Description	No. / Unit	No. / Spares kit		
			1 year	2 years	3 years
15100	Impeller	1	-	-	1
18000	Pump Shaft	1	-	-	1
19000	Suction Wear ring	1	1 set	1 set	1 set
19100	Delivery Wear ring	1	1 set	1 set	1 set
22700	Lantern ring	1	-		1
22300	Glan	1	-	1	1
23600	Liquid Deflecto	1	-	1	1
24000	Bearing Housin	1	-	-	1
25100	Support Foo	1	-	-	1
26000	Bearing SK	2	-	1	1
27000	Bearing Cover D	1	-	-	1
27100	Bearing Cover ND	1	-	-	1
31000	Shaft Sleeve	1	-	1	1
32000	Key for impeller	1	-	1	1
32100	Key for coupling	1	-	1	1
33000	Impeller Nut	1	-	1	1
33600	Bearing Locknut	1	-	1	1
41100	Lock Washer	1	-	1	1
43000	Gland Packing	5	1 set	1 set	1 set
44100	Grease Nipple	1	-	-	1
47900	Helicoil Lock Insert	1	-	1	1
48500	Internal Circlip	1	1	1	1
51100	Gasket for Casing Cover	1	1	1	1
51500	Gasket for Shaft Sleeve	1	1	1	1
52500	O-ring for Shaft Sleeve	1	1	1	1
65001	Hex. Grub Screw	4	-	1 set	1 set
66900	Impeller Screw	1	-	1	1
68202	Gasket for impeller Screw / Impeller Nut	1	1		1



7.0 CROSS-SECTIONAL DRAWING, PART NO. AND PART DESCRIPTION:

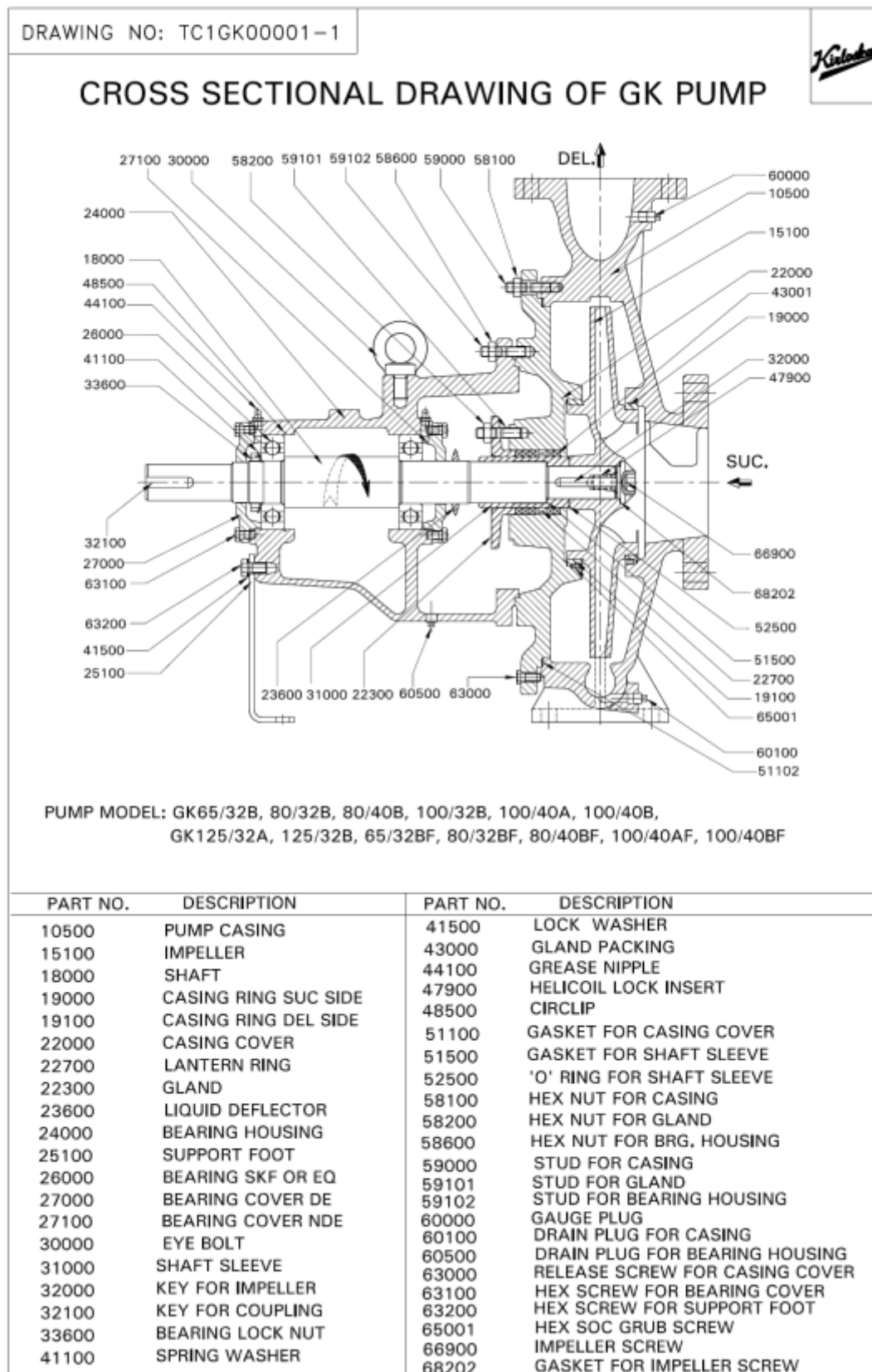



DRAWING NO: TC1GK00002-0

### CROSS SECTIONAL DRAWING OF GK PUMP

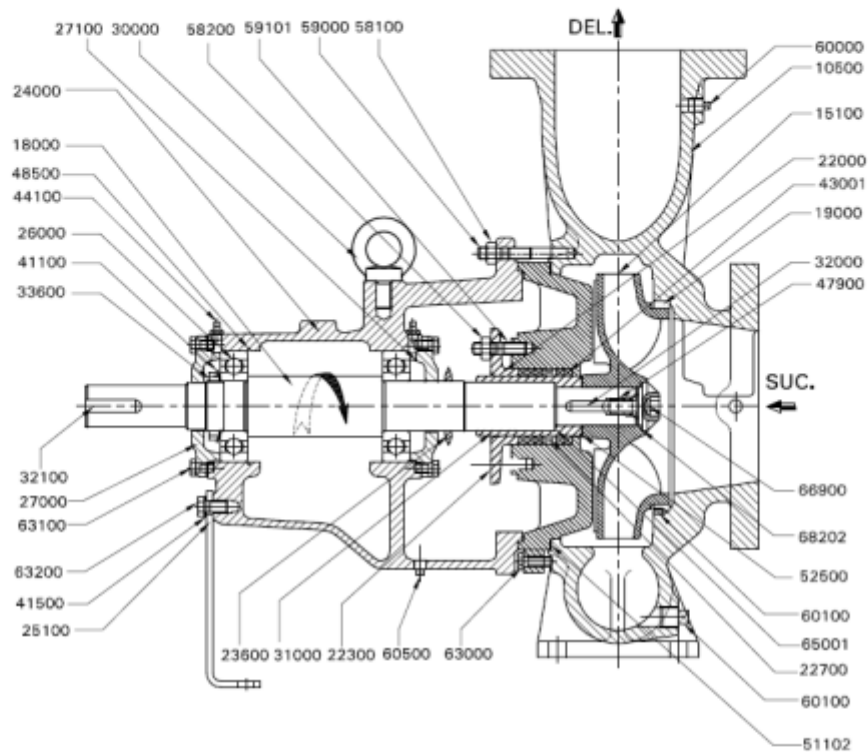

PUMP MODEL: GK100/26B & GK125/26A

PART NO.	DESCRIPTION	PART NO.	DESCRIPTION
10500	PUMP CASING	41500	LOCK WASHER
15100	IMPELLER	43000	GLAND PACKING
18000	SHAFT	44100	GREASE NIPPLE
19000	CASING RING SUC SIDE	47900	HELI COIL LOCK INSERT
19100	CASING RING DEL SIDE	48500	CIRCLIP
22000	CASING COVER	51100	GASKET FOR CASING COVER
22700	LANTERN RING	51500	GASKET FOR SHAFT SLEEVE
22300	GLAND	52500	'O' RING FOR SHAFT SLEEVE
23600	LIQUID DEFLECTOR	58100	HEX NUT FOR CASING
24000	BEARING HOUSING	58200	HEX NUT FOR GLAND
25100	SUPPORT FOOT	59000	STUD FOR CASING
26000	BEARING SKF OR EQ	59101	STUD FOR GLAND
27000	BEARING COVER DE	60000	GAUGE PLUG
27100	BEARING COVER NDE	60100	DRAIN PLUG FOR CASING
30000	EYE BOLT	60100	DRAIN PLUG FOR BEARING HOUSING
31000	SHAFT SLEEVE	60500	RELEASE SCREW FOR CASING COVER
32000	KEY FOR IMPELLER	63000	HEX SCREW FOR BEARING COVER
32100	KEY FOR COUPLING	63100	HEX SCREW FOR SUPPORT FOOT
33600	BEARING LOCK NUT	63200	HEX SOC GRUB SCREW
41100	SPRING WASHER	65001	IMPELLER SCREW
		66900	GASKET FOR IMPELLER SCREW
		68202	



DRAWING NO: TC1GK0003-0

### CROSS SECTIONAL DRAWING OF GK PUMP

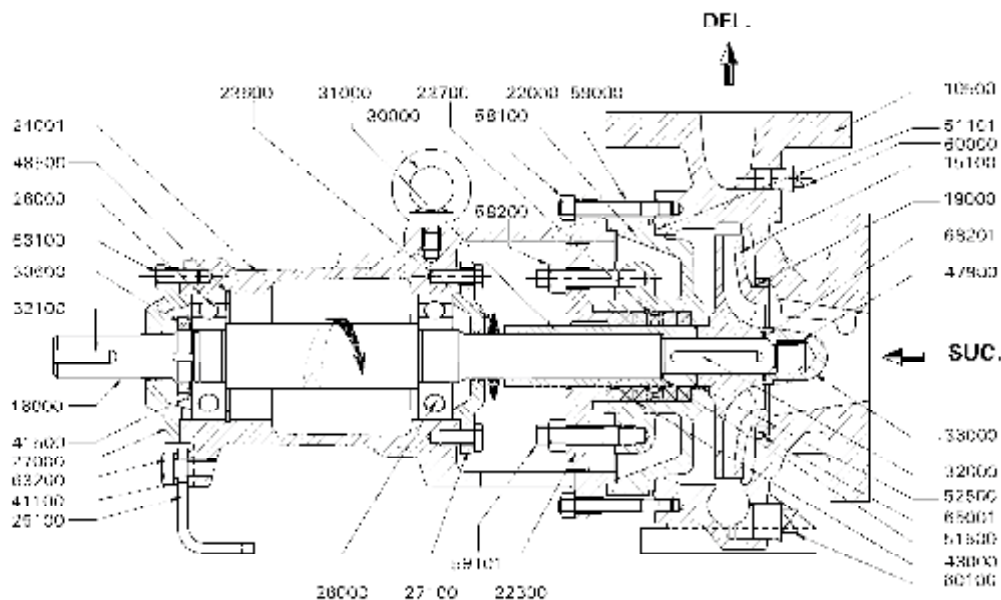

PUMP MODEL: GK52/13A, 32/13B, 40/13, 50/13, 65/13A

PART NO.	DESCRIPTION	PART NO.	DESCRIPTION
10500	PUMP CASING	41500	LOCK WASHER
15100	IMPELLER	43000	GLAND PACKING
18000	SHAFT	47900	HELICOIL LOCK INSERT
19000	CASING RING SUC SIDE	49500	CIRCLIP
22000	CASING COVER	51100	GASKET FOR CASING COVER
22700	LANTERN RING	51500	GASKET FOR SHAFT SLEEVE
22500	GLAND	52500	O-RING FOR SHAFT SLEEVE
23600	LIQUID DEFLECTOR	58100	HEX NUT FOR CASING
24000	BEARING HOUSING	58200	HEX NUT FOR GLAND
25100	SUPPORT FOOT	59000	STUD FOR CASING
26000	BEARING SKF OR EQ	59101	STUD FOR GLAND
27000	BEARING COVER DE	60000	GAUGE PLUG
27100	BEARING COVER NDE	60100	DRAIN PLUG FOR CASING
30000	FYF BOLT	63100	HEX SCREW FOR BEARING COVER
31000	SHAFT SLEEVE	63200	HEX SCREW FOR SUPPORT FOOT
32000	KEY FOR IMPELLER	65001	HEX SCW GRUB SCREW
32100	KEY FOR COUPLING	65000	IMPELLER NUT
33600	BEARING LOCK NUT	68202	GASKET FOR IMPELLER NUT
41100	SPRING WASHER		





DRAWING NO: TC1GK00004-0

### CROSS SECTIONAL DRAWING OF GK PUMP

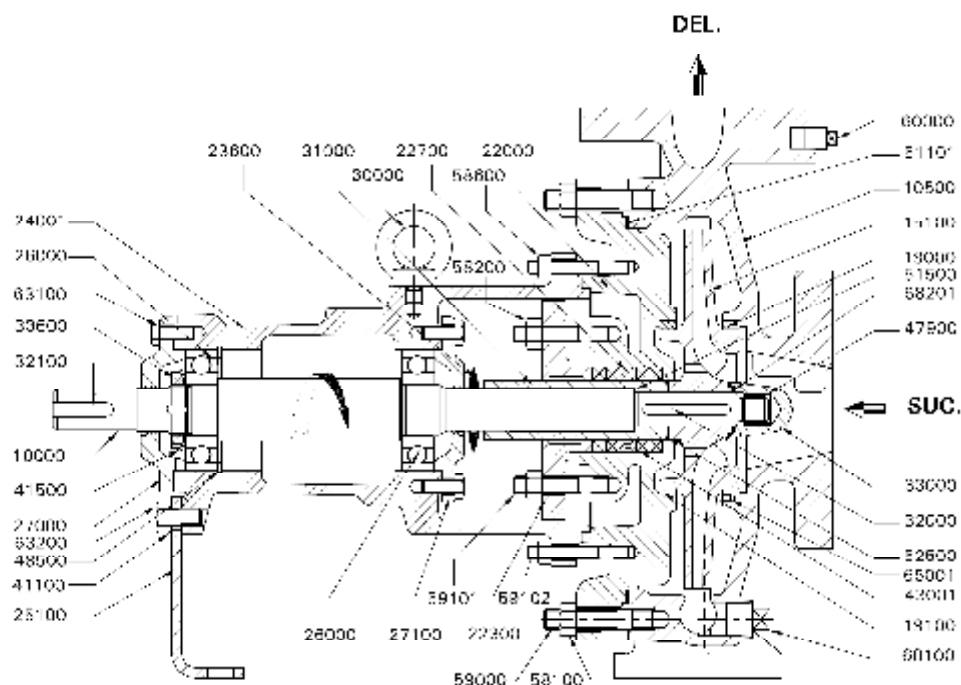

PUMP MODEL: GK32/16, 40/16, 50/16A, 32/20A, 32/20B, 40/20A, 40/20B, 50/20A

PART NO.	DESCRIPTION	PART NO.	DESCRIPTION
10500	PUMP CASING	41500	LOCK WASHER
15100	IMPELLER	43000	GLAND PACKING
18000	SHAFT	47800	HEX COIL LOCK INSERT
19000	CASING RING SUC SIDE	48500	CIRCLIP
19100	CASING RING DEL SIDE	51100	GASKET FOR CASING COVER
22000	CASING COVER	51500	GASKET FOR SHAFT SLEEVE
22700	LANIHEIN RING	52500	O RING FOR SHAFT SLEEVE
22300	GLAND	58100	HEX NUT FOR CASING
23600	LIQUID DIFFICTOR	58200	HEX NUT FOR GLAND
24000	BEARING HOUSING	58600	HEX NUT FOR BRG. HOUSING
25100	SUPPORT FOOT	59000	STUD FOR CASING
26000	BEARING SKF OR EQ	58101	STUD FOR GLAND
27000	BEARING COVER DE	58102	STUD FOR BEARING HOUSING
27100	BEARING COVER NDF	60000	GAUGE PLUG
30000	EYE BOLT	60100	DRAIN PLUG FOR CASING
31000	SHAFT SLEEVE	63100	HEX SCREW FOR BEARING COVER
32000	KEY FOR IMPELLER	63200	HEX SCREW FOR SUPPORT FOOT
32100	KEY FOR COUPLING	65001	HEX SOC GRUB SCREW
33600	BEARING LOCK NUT	33000	IMPELLER NUT
41100	SPRING WASHER	68202	GASKET FOR IMPELLER NUT



DRAWING NO: TC1GK00005-0

### CROSS SECTIONAL DRAWING OF GK PUMP

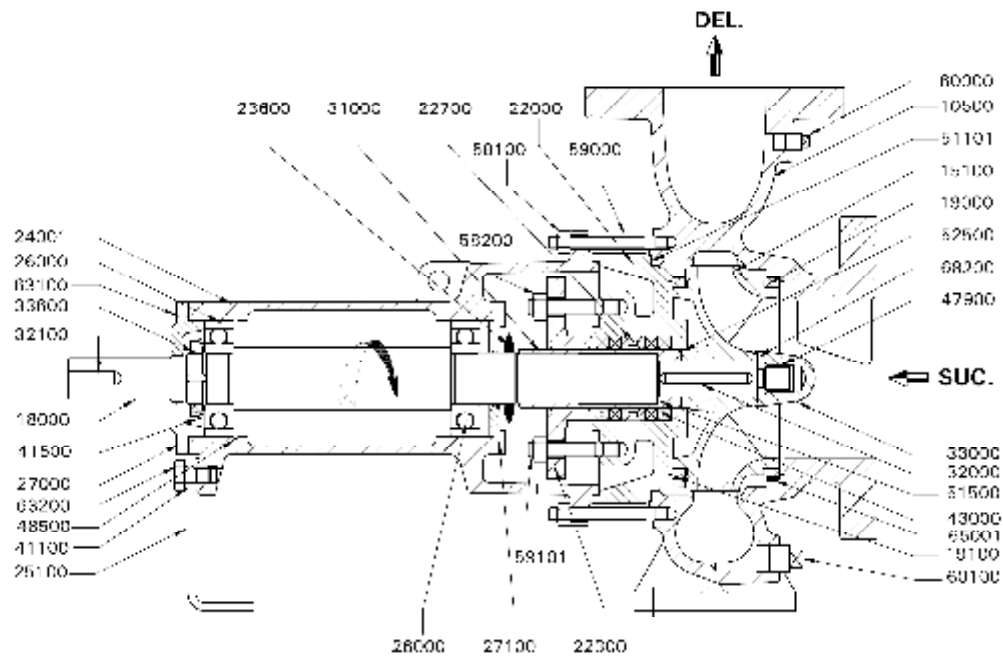

PUMP MODEL: GK65/16B, 80/16A

PART NO.	DESCRIPTION	PART NO.	DESCRIPTION
10500	PUMP CASING	41500	LOCK WASHER
15100	IMPELLER	43000	GLAND PACKING
18000	SHAFT	47900	HELICOIL LOCK INSERT
19000	CASING RING SUC SIDE	48500	CLIP
19100	CASING RING DEL SIDE	51100	GASKET FOR CASING COVER
22000	CASING COVER	51500	GASKET FOR SHAFT SLEEVE
22700	LANTERN RING	52500	O-RING FOR SHAFT SLEEVE
22300	GLAND	58100	HEX NUT FOR CASING
23800	LIQUID DEFLECTOR	58200	HEX NUT FOR GLAND
24000	BEARING HOUSING	59000	STUD FOR CASING
25100	SUPPORT FOOT	59100	STUD FOR GLAND
26000	BEARING SKF OR EQ	60000	GAUGE PLUG
27000	BEARING COVER DE	80100	DRAIN PLUG FOR CASING
27100	BEARING COVER NDE	63100	HEX SCREW FOR BEARING COVER
31000	SHAFT SLEEVE	63200	HEX SCREW FOR SUPPORT FOOT
32000	KEY FOR IMPELLER	65000	HEX SOC GRUB SCREW
32100	KEY FOR COUPLING	33000	IMPELLER NUT
33600	BEARING LOCK NUT	68202	GASKET FOR IMPELLER NUT
41100	SPRING WASHER		



DRAWING NO: TC1GK00006-0

### CROSS SECTIONAL DRAWING OF GK PUMP

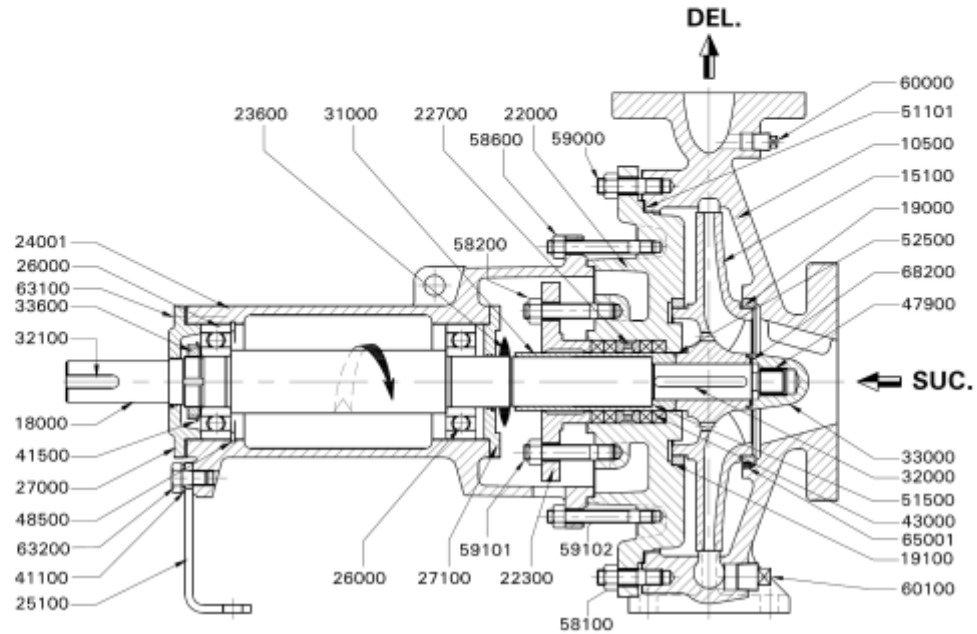

PUMP MODEL: GK65/20B, 80/20A, 100/20A, 40/26B, 50/26B, 65/26A, 65/26B, 80/26A, 50/32A

PART NO.	DESCRIPTION	PART NO.	DESCRIPTION
10500	PUMP CASING	41500	LOCK WASHER
15100	IMPELLER	43000	GLAND PACKING
18000	SHAFT	47900	HELICOIL LOCK INSERT
19000	CASING RING SUC SIDE	48500	CIRCLIP
19100	CASING RING DEL SIDE	51100	GASKET FOR CASING COVER
22000	CASING COVER	51500	GASKET FOR SHAFT SLEEVE
22700	LANTERN RING	52500	'O' RING FOR SHAFT SLEEVE
22300	GLAND	58100	HEX NUT FOR CASING
23600	LIQUID DEFLECTOR	58200	HEX NUT FOR GLAND
24000	BEARING HOUSING	58600	HEX NUT FOR BRG. HOUSING
25100	SUPPORT FOOT	59000	STUD FOR CASING
26000	BEARING SKF OR EQ	59101	STUD FOR GLAND
27000	BEARING COVER DE	59102	STUD FOR BEARING HOUSING
27100	BEARING COVER NDE	60000	GAUGE PLUG
31000	SHAFT SLEEVE	60100	DRAIN PLUG FOR CASING
32000	KEY FOR IMPELLER	63100	HEX SCREW FOR BEARING COVER
32100	KEY FOR COUPLING	63200	HEX SCREW FOR SUPPORT FOOT
33600	BEARING LOCK NUT	65001	HEX SOC GRUB SCREW
41100	SPRING WASHER	33000	IMPELLER NUT
		68202	GASKET FOR IMPELLER NUT



### 8.0 EXPLODED VIEW:

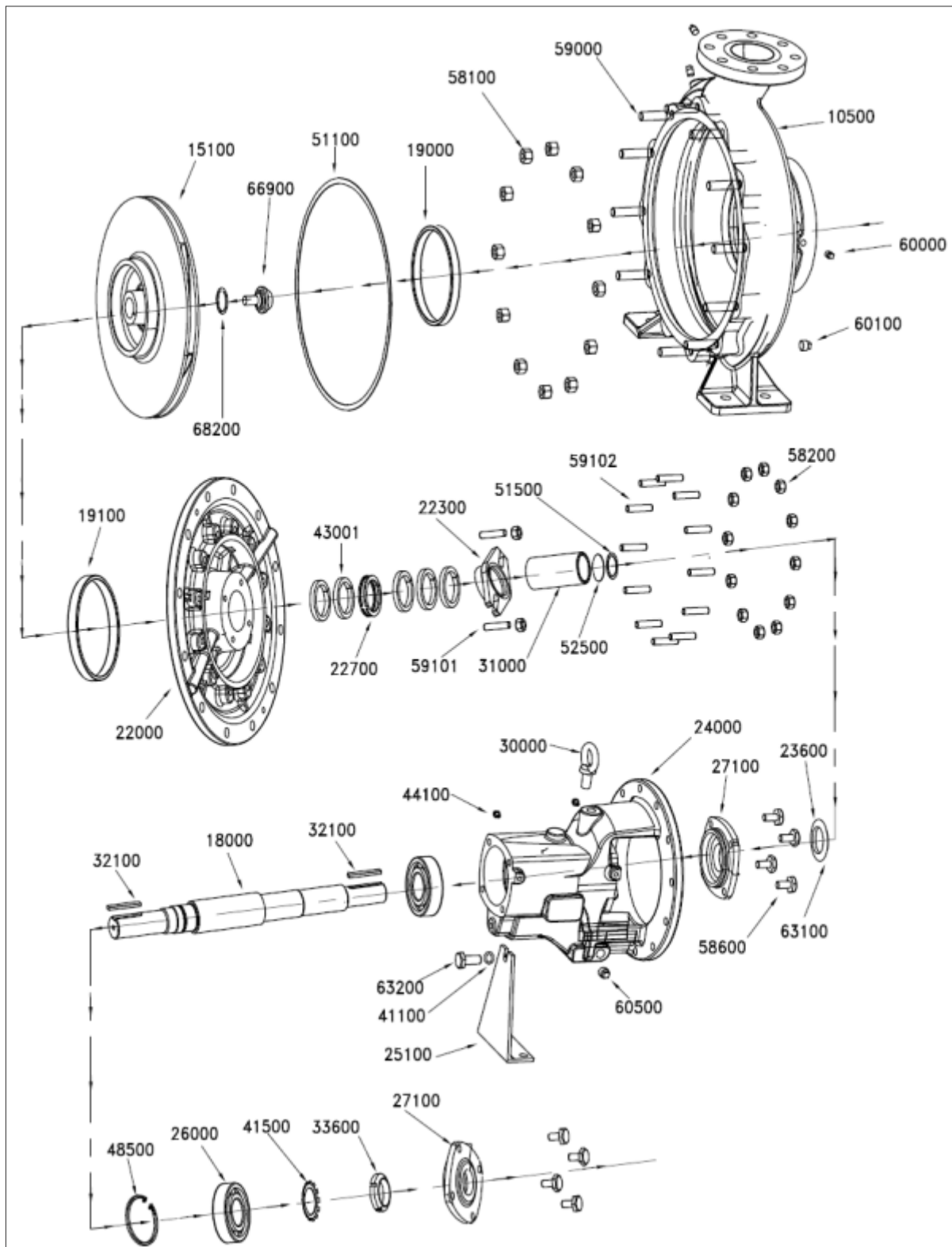

### 9.0 GENERAL OUTLINE DIMENSIONS:

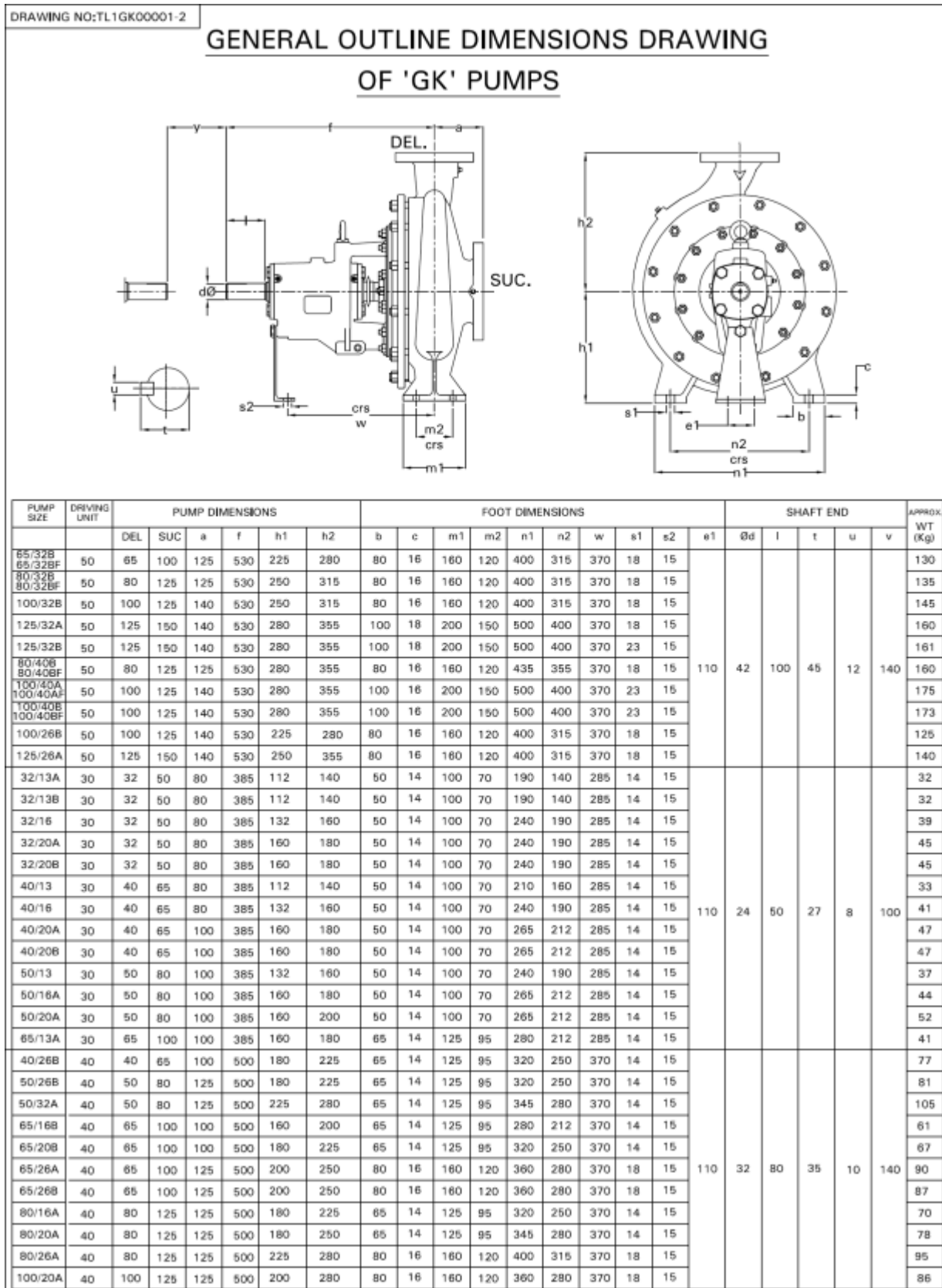



### 10.0 CUT SECTION VIEW

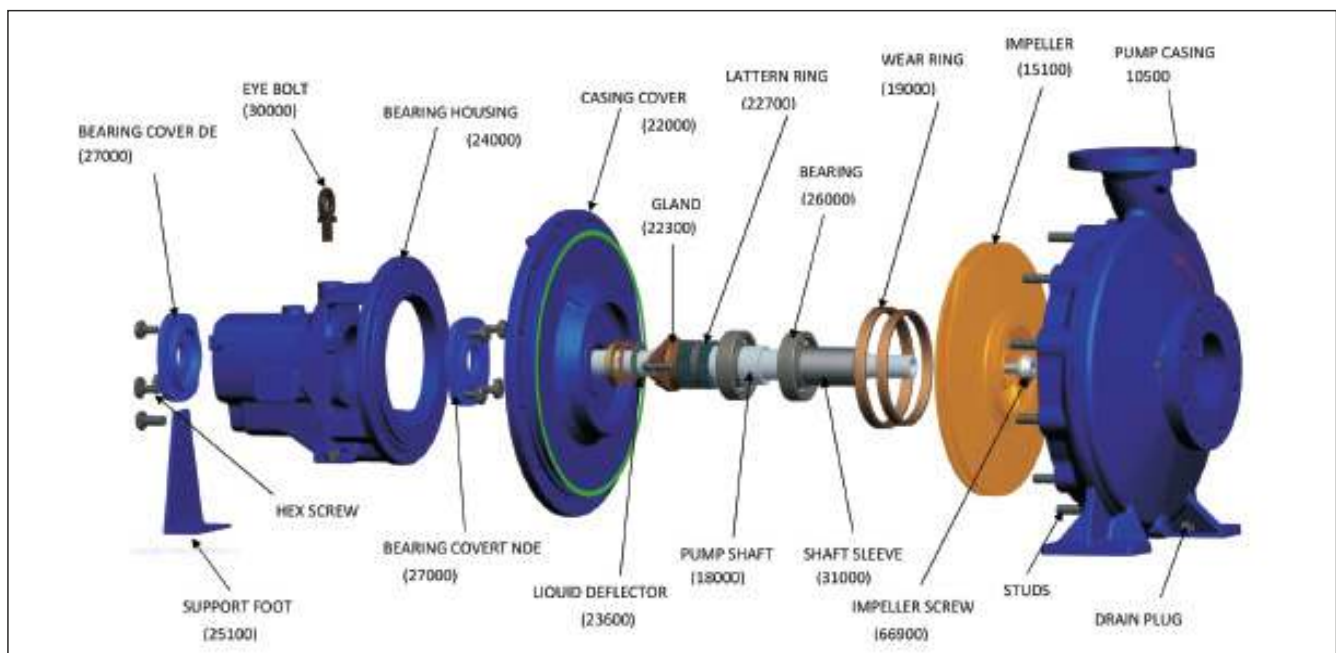
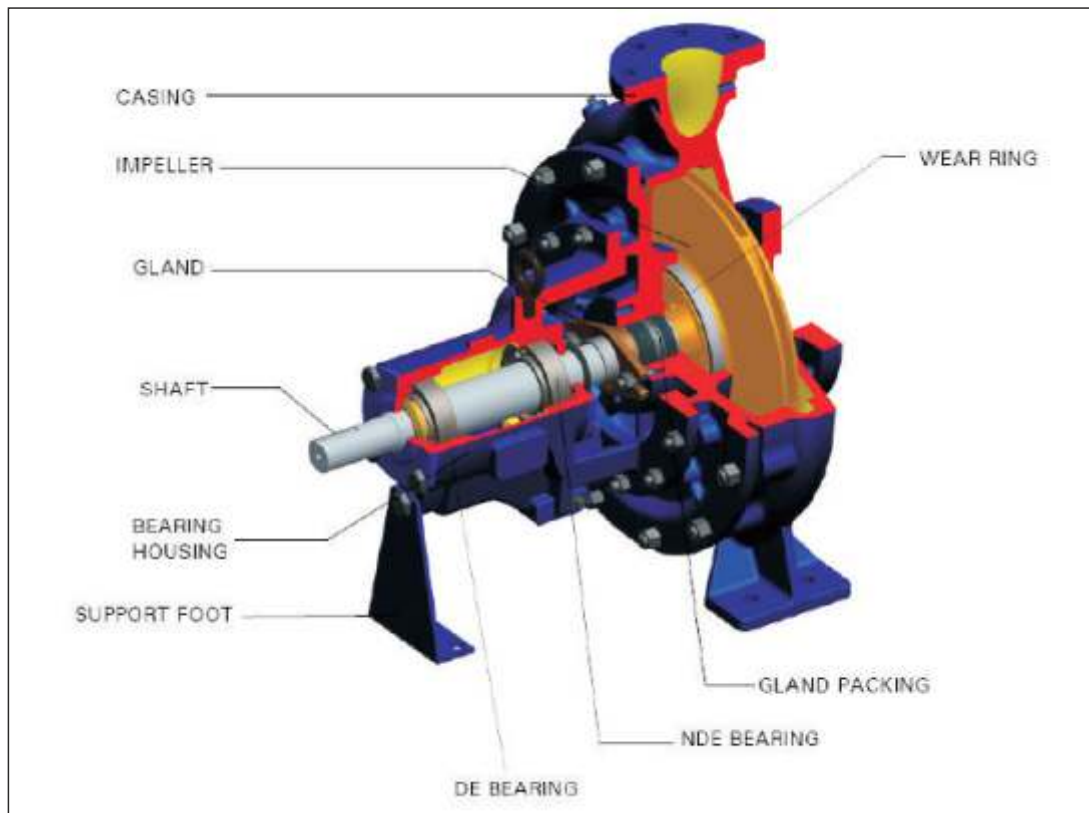



## 1.0 GENERAL INFORMATION & SAFETY REQUIREMENTS:

- 1.1 The products supplied by KBL have been designed with safety in mind. Where hazards cannot be eliminated, the risk has been minimized by the use of guards and other design features. Some hazards cannot be guarded against and the instructions below **MUST BE COMPLIED WITH** for safe operation. These instructions cannot cover all circumstances; **YOU** are responsible for using safe working practices at all times.
- 1.2 KBL products are designed for installation in designated area, which are to be kept clean and free of obstructions that may restrict safe access to the controls and maintenance access points.  
A pump duty nameplate is fitted to each unit and must not be removed. Loss of this plate could make identification impossible. This in turn could affect safety and cause difficulty in obtaining spare parts. If accidental loss or damage occurs, contact KBL immediately.
- 1.3 Access to the equipment should be restricted to the personnel responsible for Installation, operation and maintenance and they must be trained, adequately qualified and supplied with appropriate tools for their respective tasks.
- 1.4 Most accidents involving product operation, maintenance and repair are caused by failure to observe safety rules or precautions. An accident can often be avoided by recognizing potentially situations before an accident occurs. A person must be aware of potential hazard associated in activities of installation, operation and maintenance.
- 1.5 KBL requires that, all personnel that are responsible for installation, operation or maintenance of the equipment, have access to and study the product instruction manual **BEFORE** any work is done and that they will comply with all local and industry based safety instructions and regulations.
- 1.6 Ear defenders should be worn where the specified equipment noise level exceeds locally defined safe levels. Safety glasses or goggles should be worn where working with pressurized systems and hazardous substances. Other personnel protection equipment must be worn where local rules apply. Wear safety shoes, helmets and cotton overalls (apron) when you enter pump house. Noise level should not exceed 90dbA and 110 dbA for motor driven and engine driven pumps respectively.
- 1.7 Do not wear loose clothing or jewellery which could catch on the controls or become trapped in the equipment.
- 1.8 Read the instruction manual before installation, operation and maintenance of the equipment. Check and confirm that the manual is relevant copy by comparing pump type on the nameplate and with that on the manual.
- 1.9 Note the 'Limits of product application – permissible use' specified in the manual. Operation of the equipment beyond these limits will increase the risk from hazards noted below and may lead to premature and hazardous pump failure.
- 1.10 Clear and easy access to all controls, gauges and dials, etc., must be maintained all the times. Hazardous or flammable materials must not be stored in pump rooms unless safe areas or racking and suitable containers have been provided.



1.11 Use suitable earthing and tripping devices for electrical equipments.

1.12 IMPROPER INSTALLATION, OPERATION OR MAINTENANCE OF THIS KBL PRODUCT COULD RESULT IN INJURY OR DEATH.

If tool, procedure, work method or operating techniques not specifically recommended by KIRLOSKAR BROTHERS LIMITED is used, it should be ensured that it is safe for personnel around and others. It should also be ensured that the product will not be damaged or made unsafe by the operation, lubrication and maintenance or repair procedures you choose.

2.0 SAFETY INSTRUCTIONS WHILE HANDLING AND STORAGE

When lifting the pump, use the lifting points specified on general arrangement drawing. Use lifting equipment having a safe working load rating suitable for the weight specified. Use suitable slings for lifting pump which is not provided with lifting points. The use of fork-lift truck and chain crane sling equipment is recommended but locally approved equipment of suitable rating may be used.

Do not place fingers or hands, etc., into the suction or discharge pipe outlets and do not touch the impeller, if rotated this may cause severe injury. To prevent ingress of any objects, retain the protection covers or packaging in place until removal is necessary for installation. If the packaging or suction and discharge covers are removed for inspection purposes, replace afterwards to protect the pump and maintain safety.

3.0 SAFETY INSTRUCTIONS WHILE ASSEMBLY & INSTALLATION

Shaft alignment must be checked again after the final positioning of the pump unit and connection to pipe work as this may have disturbed the pump or motor mounting positions. If hot liquids (above 80°C) are being pumped, alignment should be checked and reset with the pump and motor at their normal operating temperature. If this is not possible, KBL can supply estimated initial offset figures to suit extreme operating temperatures. Failure to support suction and delivery pipe work may result in distortion of the pump casing, with the possibility of early pump failure.

4.0 SAFETY INSTRUCTIONS WHILE COMMISSIONING & OPERATION

Never attempt adjustments while the pump is running, unless otherwise specified in the operation, maintenance manual.

Do not touch any moving or rotating parts. Guards are provided to prevent access to these parts, where they have been removed for maintenance they must be replaced before operating the equipment.

Check that the pump is primed. Pump should never be run dry as the pumped liquid acts, as lubricant for the close running fits surrounding impeller and damage will be incurred.

Failure to supply the stuffing box or mechanical seal with cooling of flush water may result in damage and premature failure of the pump.

Do not touch surfaces which during normal running will be sufficiently hot to cause injury. Note that these surfaces will remain hot after the pump has stopped; allow





sufficient time for cooling before maintenance. Be cautious and note that other parts of the pump may become hot if a fault is developing.

Do not operate water pumps in temperatures below freezing point, without first checking that the pumped fluid is not frozen and the pump is free to rotate. Pumps in these environments should be drained down during in activity and re-primed before starting.

In addition to local or site regulations for noise protection, KBL recommend the use of personal ear protection equipment in all enclosed pump rooms and particularly those containing diesel engines. Care must be taken to ensure that any audible alarm or warning signal can be heard with ear defenders worn.

Be aware of the hazards relating to the pumped fluid, especially the danger from inhalation of noxious and toxic gases, skin and eye contact or penetration. Obtain and understand the hazardous substance data sheets relating to the pumped fluid and note the recommended emergency and first aid procedures.

## 5.0 SAFETY INSTRUCTIONS WHILE MAINTENANCE & SERVICING

Do not attempt repairs, you do not understand. Use proper tools.

Before attempting any maintenance on a pump particularly if it has been handling any form of hazardous liquid, it should be ensured that the unit is safe to work on. The pump must be flushed thoroughly with suitable cleaner to purge away any of the product left in the pump components.

This should be carried out by the plant operator and a certificate of cleanliness obtained before starting work. To avoid any risk to health it is also advisable to wear protective clothing as recommended by the site safety officer especially when removing old packing which may be contaminated.

Isolate the equipment before any maintenance work is done. Switch off the main supply, remove fuses, apply lockouts where applicable and affix suitable isolation warning signs to prevent inadvertent reconnection. In order to avoid the possibility of maintenance personnel inhaling dangerous fumes or vapours, it is recommended that maintenance work be carried out away from the pump location by removal of the rotating unit assembly to a suitable maintenance area.

Check and ensure that the pump operates at below the maximum working pressure specified in the manual or on the pump nameplate and before maintenance, ensure that the pump is drained down.

Wear a suitable mask or respirator when working with packing and gasket components which contain fibrous material, as these can be hazardous when the fibrous dust is inhaled. Be cautious, if other supplier's components have been substituted for genuine KBL parts, these may then contain hazardous materials.

Store all oily rags or other flammable material in a protective container in a safe place. Do not weld or flame cut on pipes/tubes that contain flammable fluids. Clean them thoroughly with nonflammable solvent before welding or flame cutting on them. Use solvent/chemical resistant gloves for hand protection.



Enriching Lives

Dispose of all wastes like gaskets, gland packing, oil batteries, packing material, etc., in accordance with local regulations. Normally this would involve incineration of liquid waste and controlled landfill of polymerized material.

Adequacy of suitable crane should be checked before lifting the pump/pump components. Also condition of pulleys, chain and lifting shackles should be checked before use.



## GENERAL INSTRUCTIONS FOR INSTALLATION, OPERATION & MAINTENANCE OF KIRLOSKAR CENTRIFUGAL PUMPS

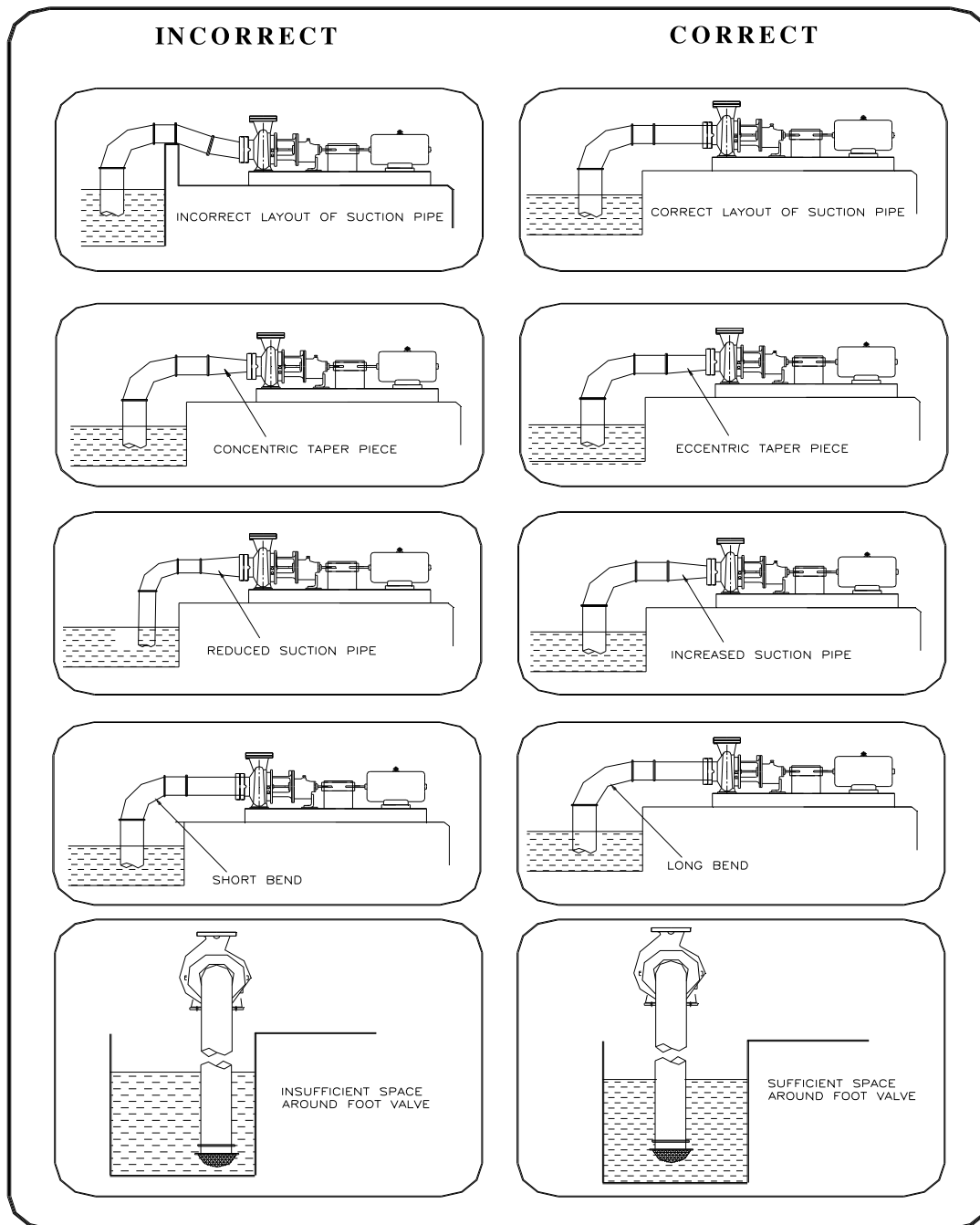



### WARNING

The equipment supplied is designed for specific capacity, speed, pressure and temperature. Do not use the equipment beyond the capacities for which it is manufactured. The equipment manufactured is also shop tested for satisfactory performance and if it is operated in excess of the conditions for which it is manufactured, the equipment is subjected to excessive stresses and strains.

### LOCATION

The pump should be located as near the liquid source as possible. This will minimize suction lift and pump will give better performance.

Ample space should be provided on all the sides so that the pump can be inspected while in operation and can be serviced whenever required.

### FOUNDATION

The foundation should be sufficiently substantial to sustain any vibrations and to form a permanent rigid support for the base plate. This is important in maintaining the alignment of a directly connected unit. A concrete foundation on a solid base is advisable. Foundation bolts of the proper size should be embedded in the concrete located by a drawing or template. A pipe sleeve of two and one half diameter larger than the bolt should be used to allow movement for the final position of the foundation bolts.

### ALIGNMENT

Pumps and the drivers supplied by the manufacturers, mounted on a common base plate are accurately aligned before dispatch. However, as the alignments are likely to be disturbed during transit to some extent and hence must not be relied upon to maintain the factory alignment. Re-alignment is necessary after the complete unit is been leveled on the foundation and again after the grout has been set and foundation bolts have been tightened. The alignment must be checked after the unit is piped up and re-checked periodically.

### FLEXIBLE COUPLING

A flexible coupling will not compensate for the misalignment of the pump and driver shafts. The purpose of the flexible coupling is to compensate for temperature changes and to permit the movement of the shafts without interference with each other while transmitting power from the driver to the pump. There are two types of misalignments.

- 1) Angular misalignment – Shaft with axis concentric, but not parallel.
- 2) Parallel misalignment – Shaft with axis parallel, but not concentric.

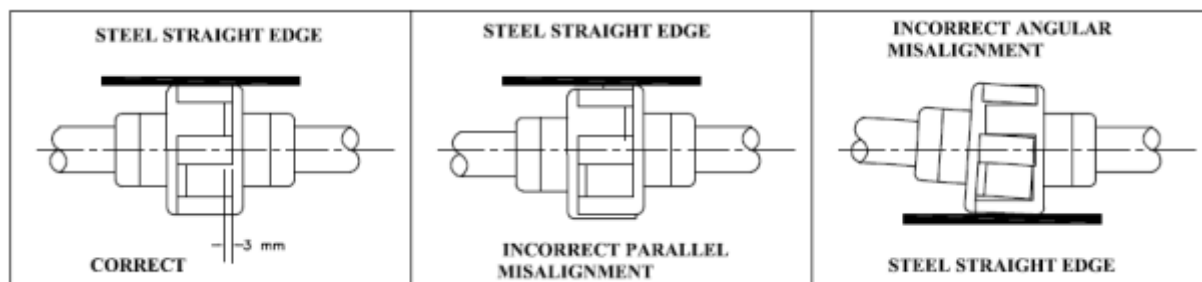



### LEVELING THE UNIT

When the unit is received with the pump and driver mounted on the base plate, it should be placed on the foundation and the coupling halves disconnected. The coupling should not be reconnected until all misalignment operations have been completed. The base plate must be supported evenly on wedges inserted under the four corners so that it will not be distorted or sprung by the uneven distribution of the weight. Adjust the wedges until the shafts of the pump and the driver are in level. Check the coupling faces, suction and discharge flanges for the horizontal and vertical position by means of spirit level.

### FLEXIBLE COUPLING ALIGNMENT

The two halves of the coupling should be at least 3mm apart so that they cannot touch each other when the driver shaft is rotated. Necessary tools for approximately checking are straight edge or an outside caliper. A check for parallel misalignment is made by placing a straight edge across both coupling periphery at the top, bottom and both the sides. The unit will be in parallel alignment when the straight edge rests evenly on the coupling periphery at all the positions. Care must be taken that the straight edge must be parallel to the axis of the shaft.

### GROUTING

When the alignment is correct, the foundation bolts should be tightened evenly but not too firmly. The unit can then be grouted by working soft concrete under the edges. Foundation bolts should not be fully tightened until the grout is hardened, usually 48 hours after pouring.

### FACTORS THAT MAY DISTURB ALIGNMENT

The unit should be periodically checked for alignment. If the unit does not stay in line after being properly installed, the following are possible causes:

- a) Setting, seasoning of the foundation.
- b) Pipe strains distorting or shifting the machines.
- c) Wear of the bearing.

### PIPING

Both suction and delivery pipes and accessories should be independently supported near the pump, so that when the flanges, bolts are tightened no strains will be transmitted to the pump casing. It is usually advisable to increase the size of both the suction and delivery pipe at the pump nozzles in order to decrease the loss of head due to friction and for the same reason piping should be arranged with minimum possible bends as possible, or it should be made with long radius wherever possible. The pipe lines should be free from scales, welding residuals, etc., and have to be mounted in such a way that they can be connected to suction and delivery flanges without any stress on the pump. It can be achieved by supporting the pipelines at appropriate locations.

### SUCTION PIPE

The suction pipe should be as short as possible. This can be achieved by placing the pump near the liquid to be pumped. The suction pipe must be kept free from air leakages. This is particularly important when the suction lift is high. A horizontal suction line must have a gradual rise to the pump. Any high point in the pipe will be filled with air and thus prevent proper operation of the pocket in the top of the reducer and the pipe. Use an eccentric piece instead.



The end of the suction pipe must be well submerged to avoid whirlpools and ingress of air but must be kept clear of any deposits of mud, silt, grit, etc. The pipe must be away from any side of the wall by 450 mm. the end of the strainer must be provided with a strainer of sufficient open area.

#### DELIVERY PIPE

A check (non-return) valve and a gate or sluice valve (regulating valve) should be installed in the discharge line. The check valve placed between the pump and the gate valve is to protect the pump from excessive pressure and to prevent water running back through the pump in case of failure of the driving machine.

Discharge piping should be provided with a sluice valve adjacent to the delivery flange to control the discharge if required.

#### VACUUM EQUALIZING LINE (AND LIQUID LINE)

If the pump draws from a system under vacuum an equalizing pipe must be carried from the highest point of the suction line, however as close to the suction flange of the pump as possible, to the top of the feed tank to keep gas bubbles that might have been entrapped in the flow from entering the pump. The line should be fitted with an isolating valve which should be closed only for maintenance work on the pump set.

Apply sealing liquid (external sealing) to the shaft seal cage to prevent entry of air in the case of the pumps with packed stuffing box. It is convenient to tap the sealing liquid from the delivery line above the non-return valve.

#### FOOT-VALVE

It is advisable to install a foot-valve to facilitate priming. The foot-valve should have sufficient clear passage for water. Care must be taken to prevent foreign matter from being drawn in to the pump or choking the foot-valve and for this purpose an efficient strainer should be provided.

---

#### STUFFING BOXES AND PACKING (only for gland packed pump)

Stuffing boxes should be carefully cleaned and packing rings placed in them. Be sure that sufficient packing is placed at the back of the water seal cage. If the water to be pumped is dirty or gritty, sealing water should be piped to the stuffing boxes from clean outside source of supply in order to prevent damage to the packing and shaft. In placing the packing, each packing ring should be cut to the proper length so that ends come together but don't overlap. The succeeding rings of packing should not be pressed too tight, as it may result in burning the packing and cutting the shaft. If the stuffing box is not properly packed, friction in stuffing box prevents turning the rotor by hand. On starting the pump, it is well to have the packing slightly loose without causing an air leak, and if it seems to leak, instead of putting too much pressure on the gland, put some heavy oil in the stuffing box until the pump works properly and then gradually tighten up the gland. The packing should be occasionally changed.

#### BALL BEARINGS

Correct maintenance of ball bearings is essential. The bearing manufacturers give the following as a guide to re-lubrication periods under normal condition.

Three monthly when on continuous duty.

Six monthly when on eight hour per day duty.

The bearings and housings should be completely cleaned and recharged with fresh grease after 2500 hrs. Or the nearest pump overhaul time.



## PRIMING

No pumping action occurs unless the pump casing is filled with the liquid. Pump casing and suction pipe must therefore be completely filled with liquid and thus all air removed before the pump is started. Several different priming methods can be used depending on the kind of installation and service involved.

- 1) Liquid level above pump level.  
Pump is set below liquid level of source of supply, so that liquid always flows to pump under positive head.
- 2) Priming with foot-valve.
  - a. When pump is installed on suction lift with foot valve at the end of suction line, fill pump with water from some outside source till all air is expelled and water flows through the air vent.
  - b. When there is liquid under some pressure in the discharge pipe, priming can be effected by bypassing the pressured liquid around the check and gate valve. Of course, the initial priming must be effected from some outside source.

**Note:** In this case, the foot-valve must be capable of withstanding pump pressure and possible surge.

Priming by ejector.

An ejector operated by steam, compressed air or water under pressure and connected to air vent at the top of casing can be used to remove air from pump and prime the pump on suction lift installations.

Priming by dry vacuum pump.

A hand or power pump sucks in all the air from the casing and the suction pipe, and thus primes the system.

## STARTING

The pump must not be started without being primed. Be sure that the driver rotates in the proper direction as indicated by a direction arrow on the pump casing.

## RUNNING

On account of its simple construction, the centrifugal pump requires practically no attention while running. Lubrication at the bearings and manipulation of the glands are the only things that need attention from the operator.

## STOPPING

Before stopping the pump; close the gate valve. This will prevent water hammer on the check valve.

STUFFING BOXES (only for gland packed pump)

Do not tighten the glands excessively. A slight dripping of water from the stuffing boxes when pump is running keeps packing in good condition.

## CASING RINGS

Casing rings are fitted in the casing to reduce the quantity of water leaking back from the high pressure side to the suction side. These casing rings are fitted to maintain a small



clearance and depend on the water in the pump for lubrication. When the rings are worn out, the clearance becomes greater and more water passes back into the suction side. The rings must be replaced from time to time to restore the pump efficiency to its normal value.

#### SPARE PARTS

A set of ball bearings, a set of casing rings and a set of gland packing rings / mechanical seal must always be kept at hand to ensure uninterrupted service from the pump. While ordering for spare parts, always give type, size and serial number of the pump as stamped on the nameplate.

#### PUMP TROUBLE

When investigating trouble with Kirloskar pumps, always remember that pumps have been tested at the factory and are mechanically correct when sent out. Discounting the possibility of damage during transit, most of the trouble in the field is due to faulty installation. Investigation shows that the majority of troubles with centrifugal pumps result from faulty conditions on the suction side.





**CAUSE-CHECK POINTS**

In case of breakdown we recommend the location of the fault by using the following table.

**BREAKDOWN CHECK POINTS:**

Pump does not deliver	1 7 8 9 10 11 12 14 15 17 18 19 23 26 52 53 54
Pump delivers at reduced capacity	1 2 3 4 5 6 7 8 9 10 11 12 13 14 15 17 18 19 20 21 22 52 53 54
Delivery performance deteriorates	1 3 7 9 10 11 12 13 14 19 20 21 22 53 58
Pump delivers too much	16 56 5 3 54
Delivery is interrupted	1 3 6 7 8 9 10 11 12 1 3 14 15 16 19 22 23 26 52 53 54 58
After stopping pump runs in reverse direction	52
Very noisy	1 2 5 6 7 8 11 12 13 15 19 20 22 50 51 52 53 58
Unsteady running of pump	19 20 22 28 29 31 32 33 34 35 36 39 40 43 44 45 46 47 50 51 54
Pump rotor locked in standstill position	22 4 1 42 46
Pump is heating up and seizing	23 26 2 4 25 26 27 36 37 38 41 43 44 45 46 50
Bearing temperature increases	19 20 21 22 28 29 30 31 32 33 34 35 36 37 38 39 40 41 42 43 44 45 47 50 51 54
Motor will not start	14 22 56
Motor gets hot or burns out	14 22 2 4 25 36 39 46 51 52 53 54 55 56 57
Motor is difficult to start	14 22 2 4 25 41 42 46 54 55 56



### CHECK POINTS:

1. Suction pipe, foot valve choked.
2. Nominal diameter of suction line too small.
3. Suction pipe not sufficiently submerged.
4. Too many bends in the suction line.
5. Clearance around suction inlet not sufficient.
6. Shut off valve in the suction line in unfavourable position.
7. Incorrect layout of suction line (formation of air pockets).
8. Valve in the suction line not fully open.
9. Joints in the suction line not leak-proof.
10. Air leaking through the suction line and stuffing box, etc.
11. Suction lift too high.
12. Suction head too low (difference between pressure at suction connection and vapour pressure too low).
13. Delivery liquid contains too much gas and/or air.
14. Delivery liquid too viscous.
15. Insufficient venting.
16. Number of revolutions too high.
17. Number of revolutions too low.
18. Incorrect direction of rotation (electric motor incorrectly connected, leads of phases on the terminal block interchanged).
19. Impeller clogged.
20. Impeller damaged.
21. Casing rings worn out.
22. Separation of crystals from the flow of pumping liquid (falling below the temperature limit/equilibrium temp).
23. Lantern ring in the stuffing box is not positioned below the sealing liquid Inlet.
24. Packing incorrectly fitted.
25. Gland tightened too much/slanted.
26. Packing not suitable for operating conditions.
27. Shaft sleeve worn in the region of the packing.
28. Bearing worn out.
29. Insufficient lubrication of bearings.
30. Ball bearings over-lubricated.
31. Oil/Grease quality unsuitable.
32. Ball bearing incorrectly fitted.
33. Axial stress on ball bearings (no axial clearance for rotor).
34. Bearings dirty.
35. Bearings rusty (corroded).
36. Axial thrust too great because of worn casing rings, relief holes obstructed.
37. Insufficient cooling water supply to stuffing box cooling.
38. Sediment in the cooling water chamber of the stuffing box cooling.
39. Alignment of coupling faulty or coupling loose.
40. Elastic element of coupling worn out.
41. Pump casing under stress.
42. Pipeline under stress.
43. Shaft runs untrue.
44. Shaft bent.
45. Rotor parts insufficiently balanced.
46. Rotor parts touching the casing.



Enriching Lives

47. Vibration of pipe work.
  48. Non-return valve gets caught.
  49. Contaminated delivery liquid.
  50. Obstruction in delivery line.
  51. Delivery flow too great.
  52. Pump unsuitable for parallel operation.
  53. Type of pump unsuitable.
  54. Incorrect choice of pump for existing operating conditions.
  55. Voltage too low/power supply overloaded.
  56. Short circuit in the motor.
  57. Setting of starter of motor too high.
  58. Temperature of delivery liquid too high.
-



Enriching Lives

## **KIRLOSKAR BROTHERS LIMITED**

Established 1888

A Kirloskar Group Company

Global Headquarters & Registered Office

"Yamuna", S. No. 98 (3-7), Plot No. 3, Baner, Pune - 411045, Maharashtra, India.

Phone: +91 (20) 27214444 | Fax No. 020 67211060

Email: [marketing@kbl.co.in](mailto:marketing@kbl.co.in) | Website : [www.kirloskarpumps.com](http://www.kirloskarpumps.com)

CIN No. L29113PN1920PLC000670.

### OUR COMPANIES

