



Enriching Lives

Instructions on installation,
operation and maintenance for
Kirloskar make
i-NS Series



KIRLOSKAR BROTHERS LIMITED

A Kirloskar Group Company

Established 1888

WARRANTY

We warrant that the pump supplied by us is free from defective material and faulty Workmanship. This warranty holds good for a period of 12 months from the date of commissioning the equipment or 18 months from the date of dispatch from our factory, whichever is earlier. Our liability in respect of any complaint is limited to replacing part/parts free of Charge ex-works or repairs of the defective Part/parts only to the extent that such replacement/repairs are attributable to or arise solely from faulty workmanship or Defective material.

This warranty holds good only for the products manufactured by us.

KIRLOSKAR BROTHERS LIMITED



CAUTION

1. DO NOT LOWER OR LIFT THE PUMP WITH THE HELP OF CABLES.
2. DO NOT FILL ANY LIQUID INSIDE THE MOTOR.
3. DO NOT MEGGER CONTROL PANEL CONTROL CIRCUIT TERMINALS.
4. DO NOT RUN THE PUMP DRY OR IN REVERSE DIRECTION.
5. DO NOT RUN THE PUMP WITHOUT CONTROL PANEL.
6. DO NOT RUN THE PUMP WITH CONTROL UNIT IN BYPASSED CONDITION.
7. DO NOT MEGGER CONTROL CABLE OF THE PUMP WITHOUT DISCONNECTING FROM THE CONTROL PANEL.

INDEX

SR. NO.	CONTENTS	PAGE NO.
1	GENERAL	5
2	INSTALLATION	7
3	OPERATION	8
4	MAINTENANCE	10
5	TECHNICAL DATA	11
6	OVERHAULING	18
7	CROSS SECTIONAL DRAWING AND PARTLIST	19
8	OUTLINE DRAWING & DIMENSIONS SHEET	22
9	GENERAL ARRANGEMENT DRAWING & DIMENSIONS SHEET	23
10	SPARE PARTS	24
11	BREAK DOWN & CHECK POINTS	24
12	GENERAL INFORMATION & SAFETY INSTRUCTIONS	26
13	ENVIRONMENTAL ASPECT & PRODUCT RECYCLE PROGRAM	29

NOTE:

- Please ensure these instructions are read fully before installation and operation of the pump.
- Please furnish complete nameplate details, name of parts, part nos. And material of construction while ordering spare parts for the pump

1. GENERAL :

1.1 KIRLOSKAR submersible sewage pumps type “iNS” is available in the following models.

iNS PUMP MODELS
40/20, 50/20
50/26, 80/26, 100/26, 150/26
40/32, 50/32, 65/32, 100/32, 150/32
50/36
80/40

The above models are offered with two vane enclosed impellers, three vane semi-open impeller except 40/20, 40/32 & 50/20.

Unit Size I: 2.2KW/4P to 5.5KW/4P

Unit Size II: 7.5KW/4P to 11KW/4P

Unit Size III: 15KW/4P to 22KW/4P

The following chart (1) can be referred to know the pumps available in type of impellers ratings.

Sl. No.	IMPELLER TYPE									TOTAL	Rating in 4 pole								SUM	VARIETY	
	PUMP	N	QM	Q	QT	NS	QMB	NM	QAM		2.2	3.7	5.5	7.5	8.2	11	15	18.5			22
1	40/20				*					1	*	*							2	2	
2	40/32				*					1	*	*							2	2	
4	50/20				*					1	*	*							2	2	
5	50/26	*	*	*	*					4	*	*	*						4	24	
6	50/32	*	*	*	*					3	*	*	*	*	*	*	*	*	6	18	
7	50/36		*	*	*					1	*	*	*	*	*	*	*	*	4	4	
8	65/32	*	*	*	*	*				6	*	*	*	*	*	*	*	*	6	24	
9	80/26	*	*	*	*					4	*	*	*	*	*	*	*	*	4	24	
10	100/26	*	*	*	*					4	*	*	*	*	*	*	*	*	4	24	
11	100/32	*	*	*	*					4	*	*	*	*	*	*	*	*	4	16	
12	150/26	*	*	*	*					4	*	*	*	*	*	*	*	*	4	32	
13	100/32	*	*	*	*					4	*	*	*	*	*	*	*	*	4	8	
14	80/40	*	*	*	*					4	*	*	*	*	*	*	*	*	2	12	
TOTAL										48	8	4	3	6	6	7	7	9	9	12	204
NO. OF HYDRAULICS WITH VARIOUS IMPELLERS-										48											
NO. OF COMBINATIONS WITH AVAILABLE RATINGS AND HYDRAULICS-																				204	

Chart (1)

* - design available

E.g.: pump 65/32 is available in 6 types of impellers and ratings from 7.5 kW to 22 kW.

Pump can be selected as:

- NS65/32QMB 7.5/4 i
- NS65/32N 11/4 i

1.2 The pump comprises of three units :

- I. **Pump unit** % comprises of a delivery casing having wide volute opening and non-clog type of impeller. The casing is connected with connector unit or stand as per order.
- II. **Stuffing box unit** % comprises double mechanical seal and mechanical seal housing filled with oil for lubricating the seals. The seal behind the impeller is having seat ring of silicon carbide V/s silicon carbide and second seal comprises of carbon ring V/s stainless steel ring.
- III. **Electrical motor unit** % These pumps are provided with submersible three phase squirrel cage induction motors in watertight housing. The entire motor unit is air tested to ensure the leak tightness of the joints. Moisture sensor is provided in the mechanical seal housing to give the indication to control panel which in turn trips the motor, when the seal near impeller fails. The pump is provided with high and low liquid level controllers which avoids dry running of pump.

- 1.3 The iNS pump can be supplied in portable or with fixed arrangement. When the pump is supplied with portable type, hose, connection should be provided to avoid weight of pipe line on the pump casing. The casing is provided with stand for support. For stationary application, the pump is mounted on the support bracket and is connected to the delivery bend through a rubber diaphragm and connector unit. The pump is slides over the guide pipes without disconnecting/disturbing the delivery pipe line.
- 1.4 iNS pump is supplied with wall mounted control panel. These control panels are supplied either with **DIRECT ON LINE** type starter, **STAR DELTA** or **ATS** type starters. These panels are designed for smooth running of pump-set. The pump gets switched off automatically and is protected against the following.
- Contamination of oil with pumped liquid.
 - Dry running of pump.
 - Single phasing/reverse phasing.
 - Over load.
 - Over heating of winding [against order].
- The coding of leads of the cables is clearly marked on each lead and the connections to the control panel should be made as per connections diagram of control panel and below shown figure (1) & (2).

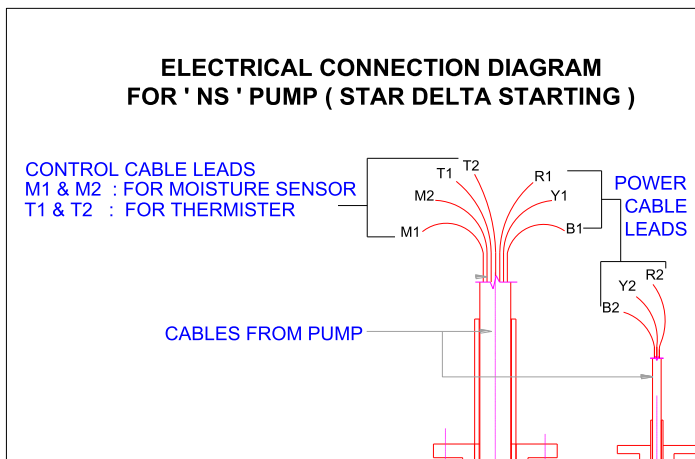

Figure (2): SDS-connection

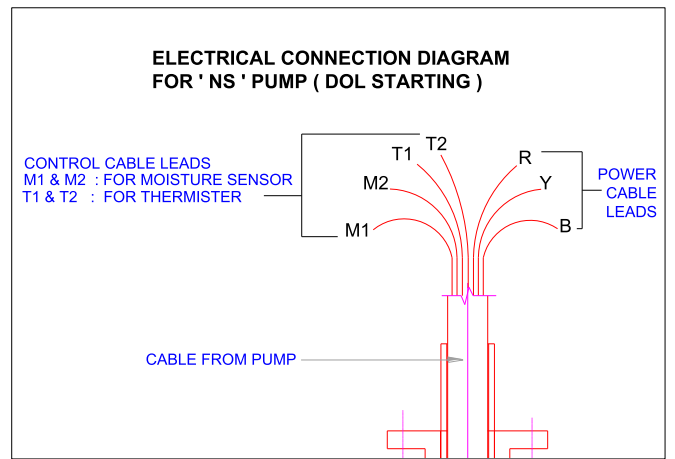

Figure (3): DOL-connection

- 1.5 As a standard scope of supply, iNS pumps are supplied with 10 m long cable. This cable consists of power cable having 4 and 3 core for Star Delta starting (for rating from 11kW to 22kW) and 4 core cables for DOL (for rating upto 9.3kW) starting suitably designed for the voltage and current. The control cable of 4 cores 1.5 sq.mm is used for thermistor and moisture sensor 2 wires each.

2. INSTALLATION :

- 2.1 The iNS pumps of stationary arrangement are supplied with pump connector unit and this connector unit is connected to pump support bracket with guide shoe & rubber diaphragm to make it leak proof joint.



Figure (3): Portable installation view

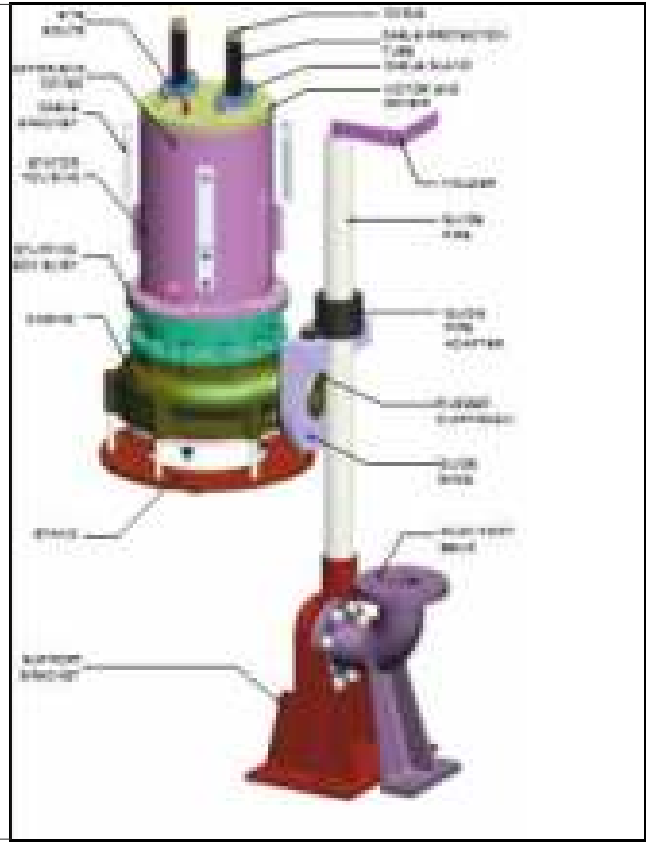

Figure (4): Stationary installation view

2.1.1 Installation of support bracket & duck foot bend %

Before installing the pump, ensure that sump bottom is flat and leveled. The support bracket & duck foot bend should be attached and fixed to the sump bottom with foundation bolts, so that the guide pipe shall be exactly vertical.

Ensure that support bracket and bend are located correctly relative to descending pump vertical guide pipe and discharge pipe.

- 2.1.2 **Lowering the pump** - Attach the guide shoe & guide pipe adapter to the pump. The unsupported length of guide pipe should not exceed 6 m.

- 2.1.3 Fix the guide pipe in the support bracket and locate the vertical position of guide pipe holder at the top of the pit. Now the grout the guide pipe holder.

- 2.1.4 Insert the above assembly in the guide pipe by dismantling the guide pipe holder & refit the holder in the guide pipe.

- 2.1.5 **Check**-Lower the pump with the help of chain. While sliding over the guide pipe into the sump, check that the cable is not slugging and is not under tension.

- 2.1.6 Ensure that the pump position is exactly vertical on the support bracket. Check by giving a jerk.

- 2.1.7 Before taking the pumping station into use, check that there are no loose solid pieces or other material on bottom of sump that would damage the pump.
- 2.1.8 DO NOT LIFT THE PUMP WITH THE HELP OF CABLES.
- 2.2 The NS pumps supplied for **portable installation** requires no foundation. Only ensure that the delivery pipe line is well supported and its weight is not acting on pump casing directly.
- 2.3 Use chain with intermediate hooks for holding to lower or lift the pump. This type of chain is specially design to avoid the tendency of the operator to lift the pump with the help of cable causing damage & replacement of the cable unit. While selecting size of the chain, refer weight of the pump given in chart (6). and chain capacity as per below chart (2) We recommend use of non-return valve in delivery pipe line located before sluice valve.
- 2.3.1 As per IS: 2429 the following sizes of chains can be used upto the weight as mentioned in the below chart.

Nom. Chain Size (mm)	Lifting capacity (Tonnes)
6.3	0.5
8.0	0.8
10.0	1.25
12.5	2.0

Chart (2)

3. OPERATION

- 3.1 Prior to commissioning of the pump, check the following.
 - 3.1.1 Check the pump rotates freely by hand.
 - 3.1.2 FILL THE OIL INSIDE THE MECHANICAL SEAL HOUSING WITH PROPER GRADE REFER CHART (5) OF CLEAN OIL FREE FROM MOISTURE. ENSURE THE MECHANICAL SEAL HOUSING OF THE PUMP IS DULY FILLED AS PER CHART NO. (6). CHECK THE OIL PLUG OF THE MECHANICAL SEAL HOUSING IS INTACT.
 - 3.1.3 Check the insulation resistance of winding by using 500 V megger. The insulation resistance of winding should not be less than 100 MΩ at phase to phase and phase to Earth. This test should be carried out at free end of the cable. If the insulation resistance is found less than 100MΩ then please consult our service personnel.

For continuity test, connect the two wires of megger between the two ends of the same phase of motor. It should show zero resistance. This test should be carried out for the phases.

The resistances across two moisture sensing wires (refer drawing 1 & 2) M1 and M2 should be above 10 MΩ. Make sure to remove control cable connections from terminal board [M1 and M2] before testing this. If the resistance found less, please consult our service department. The megger test for phase to phase and phase to Earth should be conducted serially. The megger test should show insulation resistance above 100 MΩ.

- 3.1.4 The control panel is provided with auto/manual switch. When the switch is on "Manual" position the pump set can be started manually by the start push button provided the liquid level is above the low level electrode. If the switch is on "Auto" position it will start automatically if liquid level in the sump, is above the high level electrode. The pump set get switched off automatically for any position of Auto Manual switch if liquid level goes down just below the low level electrode. This is indicated by glowing of red lamp on control panel.

When the pumped liquid gets mixed up with the oil in the casing cover, it is indicated by glowing of red lamp under name plate contamination. After rectification of the fault, resetting switch is to be



pressed first and then the pump set will get started by pressing "Starting switch" if it is operated on "Manual position" or automatically if control panel is operating on "Auto position".
Before change over from star to delta connection, time delay should be sufficient to allow the motor to attain its normal running speed. The same depends upon the load of the motor and it is generally around 10 second.

3.1.5 LIQUID LEVEL CONTROLLERS ARE INCORPORATED IN THE PANEL TO PROTECT THE PUMP FROM DRY RUNNING. THE LOW LEVEL ELECTRODE SHOULD BE POSITIONED IN SUCH A MANNER THAT LOWEST END OF ELECTRODE REMAINS ABOVE MOTOR BODY. IF LOW LEVEL ELECTRODE IS NOT INSTALLED PROPERLY THE MOTOR BODY IS LIKELY TO BE HEATED UP AS COOLING OF MOTOR IS DONE BY LIQUID IN THE SUMP AROUND THE STATOR HOUSING. HENCE SUBMERGENCE UPTO FULL CORE LENGTH OF MOTOR IS REQUIRED.

3.1.6 Before starting the pump, check the direction of rotation is as outline below.
Hoist up the pump and momentarily switch on the power. If the connections are correctly made the pump should jerk in anticlockwise direction when viewed from top. If the pump jerks in opposite direction, change two phases of the incoming leads to the control panel. In no case the direction of rotation should be changed by changing the leads of motor terminals. Do not run the pump dry. Just check in which direction the pump jerks.

3.2 While putting the pump in operation, follow the procedure outlined below.

3.2.1 Start the pump. Let the motor pick-up its full speed.
3.2 Open the discharge valve slowly.

3.3 Check during running that %

3.3.1 The pump is running smooth.
3.3.2 Power consumption is within limit.
3.3.3 Head and capacity developed by the pump is as specified.
3.1 Stop the pump immediately if any defects are detected and must not be started unless they are rectified. Report immediately to the supplier if it is not possible to rectify the defect.

3.4 STOPPING THE PUMP:

3.4.1 Pump should be switched off only after closing the delivery sluice valve.

4. MAINTENANCE:

Preventive maintenance schedule is the periodical checks and precautions by which possibilities of failure and break-downs are minimized.

4.1 Daily checks %

4.1.1 An hourly record of the delivery pressure and power input to the pump should be maintained.
4.1.2 Noise and vibrations is the first sign of impending troubles like bearing failure, choking of impeller or casing and such other operating troubles. The pump performance should be checked for noise and vibration.

4.2 Periodical checks %

4.2.1 The lubrication of mechanical seals should be checked. The lubricant might get contaminated with foreign material or get blackened due to overheating. In such cases, oil chamber should be flushed and filled with fresh oil. Before filling, heat the oil [Servo system 317] to 140°C. This is required to remove moisture present in the oil.
4.2.2 THE ELECTRODES/FLOAT SWITCHES SHOULD BE CLEANED WHENEVER POSSIBLE BUT NOT LATER THAN 15 DAYS FOR SMOOTH WORKING OF PUMP.
4.2.3 Clean the sump if there are chances of deposition of the contents of liquid handled.

4.3 Annual checks [after one year minimum] %

- 4.3.1 The pump portion of the motor pump set should be overhauled completely to check the clearance and to replace the worn-out parts. Clearance between impeller and casing ring and casing cover are very important.
- 4.3.2 The effect of liquid handled on pump components should be checked. If abnormal corrosion, erosion is observed then the components should be replaced with that of suitable material.

5. TECHNICAL DATA:

- 5.1 iNS pumps are supplied at maximum speed 1450 rpm having 4 pole motors. However the same pump can be offer at 980 rpm having 6 pole motor. The direction of rotation is clockwise when viewed from the motor top.

5.2 Specifications of BEARINGS:

The shaft is supplied with antifriction ball bearings at both ends. The bearing specifications are given below. The designations of bearings are as per SKF catalogue. However, equivalent bearing in type, capacity and dimensions are also can be used.

Sr. No.	UNIT SIZE	Lower bearing	Qty.	Upper bearing	Qty.
1.	UNIT-I	6307-2RS1F	1	6305-2RS1	1
2.	UNIT-II	6309-2RS1	1	6306-2RS1	1
3.	UNIT- II	6309-2RS1	1	6306-2RS1	1

Chart (3)

5.3 LUBRICATION:

Bearings of iNS pumps are sealed for life. Re-lubrication of these bearings is not required.

5.4 Mechanical SEALS:

Pumps are supplied with back to back seals of following type:

Sr. No.	UNIT SIZE	Seal size in mm	MECHANICAL SEAL DATAILS	
			Inboard	Outboard
1	UNIT-1	22	SiC. Face Vs SiC.	Carbon Vs Ceramic
2	UNIT-II	40		
3	UNIT-III	40		

Chart (4)

5.5 Lubrication for mechanical SEALS:

The outboard mechanical seal is lubricated by oil provided in casing cover. The lubricating oil should confirm the following grades of oil available in the market.

Name	OIL specification	Name	OIL specification
ELF	ACANTIS HM 68	VEEDOL	ATLINE 68
IOC	SERVOSYSTEM 57/68/317	PENNZOIL	PENNZBELL AW 68
HPCL	ENKLO 57	BPCL	HYDRO 68
CASTROL	HYSPIIN EP 68	ESSO	AW68
GULF	HARMONY 68	MOBIL	AW68
SHELL	TELLUS 68		

Chart (5)

The oil used should be highly refined straight mineral product of high demulsibility free from running and acid forming tendencies. Detergent Oil may cause foaming and should not be used.

5.6 INTERCHANGIBILITY CHART

PUMP UNIT:

Part No.	1070506	1510502	1900507	4600507	4650507	3830509	3410508	209150A
Name Of The Part	Pump Casing	Impeller	Casing Ring	Wear Plate	Suction Plate	Support Plate .	Tie Bar For Stand	Spacer For Suction Plate
Total parts	34	41	7	8	26	9	13	2
40/20QT	1	1	NA	NA	1	1	1	1
40/32QT	2	2	NA	NA	2	2	2	1
50/20QT	3	3	NA	NA	3	1	3	1
50/26N	4	4	1	NA	NA	4	4	NA
50/26QM	6	5	NA	NA	4	4	4	1
50/26Q	5	6	NA	1	NA	3	4	NA
50/26QT	6	6	NA	NA	5	4	4	1
50/26NB	4	7	1	NA	NA	3	4	NA
50/26QMB	6	8	NA	NA	6	4	4	1
50/32N	7	9	2	NA	NA	5	5	NA
50/32QM	8	10	NA	NA	7	6	5	1
50/32QT	8	11	NA	NA	7	6	5	1
50/36QM	9	12	NA	NA	8	7	6	1
65/32N	10	13	3	NA	NA	5	7	NA
65/32QM	11	14	NA	NA	9	6	7	1
65/32Q	12	15	NA	2	NA	5	7	NA
65/32QT	11	15	NA	NA	10	6	7	1
65/32NB	10	16	3	NA	NA	5	7	NA
65/32QMB	11	17	NA	NA	11	6	7	1
80/26N	13	18	4	NA	NA	3	8	NA
80/26QM	14	19	NA	NA	12	4	8	1
80/26Q	15	20	NA	3	NA	3	8	NA
80/26QT	14	20	NA	NA	13	4	8	1
100/26N	16	21	5	NA	NA	3	9	NA
100/26QM	17	22	NA	NA	14	4	9	1
100/26Q	18	23	NA	4	NA	3	9	NA
100/26QT	17	23	NA	NA	15	4	9	1
100/32N	19	24	5	NA	NA	5	10	NA
100/32QM	20	25	NA	NA	16	6	10	1
100/32Q	21	26	NA	5	NA	5	10	NA
100/32QT	20	26	NA	NA	17	6	10	1
150/26N	22	27	6	NA	NA	3	11	NA
150/26QM	23	28	NA	NA	18	4	11	1
150/26Q	24	29	NA	6	NA	3	11	NA
150/26QT	23	29	NA	NA	19	4	11	1
150/26NB	22	30	6	NA	NA	3	11	NA
150/26QMB	23	31	NA	NA	20	4	11	1
150/26NM	25	32	6	NA	NA	3	11	NA
150/26QNM	26*	33	NA	NA	21	4	11	1
150/32N	27	34	6	NA	NA	5	12	NA
150/32QM	28	35	NA	NA	22	6	12	1
150/32Q	29	36	NA	7	NA	5	12	NA
150/32QT	28	36	NA	NA	23	6	12	1
80/40N	30	37	4	NA	NA	8	13	NA
80/40QM	31	38	NA	NA	24	9	13	NA
80/40Q	32	39	NA	8	NA	8	13	NA

80/40QT	31	39	NA	NA	25	9	13	1
80/40NM	33	40	7	NA	NA	8	13	NA
80/40QNM	34	41	NA	NA	26	9	13	1

STUFFING BOX UNIT:

Part No.	2320201	2300202	9320203	5252206	5253207	3500208	5110505	523550B
Part Name	Mechanical Seal Housing	Mechanical Seal	Moisture Sensor 1	Moisture Sensor O-Ring	Mechanical Seal Housing O-Ring	Stuffing Box Bush	Pump Casing Gasket	Suction Plate O-Ring
Total	7	2	1	1	1	7	5	5
I	20	1	1	1	1	1	1	1
	26	2	1	1	1	2	2	2
	32	3	1	1	1	3	3	3
II	26	4	2	1	1	4	4	2
	32	5	2	1	1	5	5	3
	36	6	2	1	1	6	6	4
III	26	4	2	1	1	4	4	2
	32	5	2	1	1	5	5	3
	36	6	2	1	1	6	6	4
	40	7	2	1	1	7	7	5

B) MOTOR UNIT

Part No.	Name of the part	Total No. of parts	I			II			III						
			2.2	3.7	5.5	7.5	9.3	11		15		18.5		22	
								P	C	P	C	P	C	P	C
1640101	Rotor Shaft Assembly	9	1	2	3	4	5	6		7		8		9	
2710102	Bearing Cover	2	1	1	1	2	2	2		2		2		2	
2601103	Lower Bearing	2	1	1	1	2	2	2		2		2		2	
4860104	External Circlip	2	1	1	1	2	2	2		2		2		2	
2602105	Upper Bearing	2	1	1	1	2	2	2		2		2		2	
9110302	Stator	9	1	2	3	4	5	6		7		8		9	
5233303	O-Ring For Upper Bearing	2	1	1	1	2	2	2		2		2		2	
9120304	Terminal Board	2	1	1	1	1	1	2		2		2		2	
9090401	Motor End Cover	2	1	1	1	1	1	2		2		2		2	
5234402	O Ring For Motor End Cover	1	1	1	1	1	1	1		1		1		1	
9141403	Cable Seal	2	1	1	1	2	2	3	4	3	4	3	4	3	4
8453406	Washer For Cable Seal	2	1	1	1	2	2	3	4	3	4	3	4	3	4
9781408	Cable Protection Tube	2	1	1	1	2	2	3	4	3	4	3	4	3	4
8455411	Machined Washer	2	1	1	1	2	2	3	4	3	4	3	4	3	4
9101413	Cable Gland	2	1	1	1	2	2	3	4	3	4	3	4	3	4
9131415	Power + Control Cable	2	1	1	1	2	2	3	4	3	4	3	4	3	4
4930417	Hose Clip	2	1	1	1	2	2	3	4	3	4	3	4	3	4
4400418	Potting Cup	2	1	1	1	2	2	3	4	3	4	3	4	3	4
3000420	Eye Bolt	1	1	1	1	1	1	1		1		1		1	
3200501	Key For Impeller	2	1	1	1	2	2	2		2		2		2	
6820504	Gasket For Impeller	2	1	1	1	2	2	2		2		2		2	
669050A	Impeller Screw	1	NA	NA	NA	1	1	1		1		1		1	

330050A	Impeller Nut	1	1	1	1	NA	NA	NA	NA	NA	NA
---------	--------------	---	---	---	---	----	----	----	----	----	----

C) CONNECTOR UNIT

Part No.	2830606	9170604	9180601	9190603	9390605	9410607	1450602	9280608
Name Of The Part	Duck Foot Bend	Support Bracket	Guide Shoe	Rubber Diaphragm	Gasket For Bend	Guide Pipe	Guide Pipe Adapter	Guide Pipe Holder
Total No. of parts	6	6	6	6	6	1	1	1
40 mm DEL.	1	1	1	1	1	1	1	1
50 mm DEL.	2	2	2	2	2	1	1	1
65 mm DEL.	3	3	3	3	3	1	1	1
80 mm DEL.	4	4	4	4	4	1	1	1
100 mm DEL.	5	5	5	5	5	1	1	1
150 mm DEL.	6	6	6	6	6	1	1	1

5.7 WEIGHTS OF PUMPS AND OIL QUANTITY:

Sr. No.	Pump Model	Kw	Size Code	Unit	Oil Quantity (Liters)	Approx. Pump Weight (Kg.)	Connector unit Weight (Kg.)
1	40/20QT	3.7	14	1	1.2	130	75
2	40/20QT	2.2	24	1	1.2	130	75
3	50/20QT	2.2	24	1	1.2	134	75
4	50/20QT	3.7	24	1	1.2	134	75
5	50/20QT	5.5	24	1	1.2	139	75
6	50/26N	3.7	31	1	1.6	150	75
7	50/26N	5.5	31	1	1.6	155	75
8	50/26N	7.5	31	2	4.0	174	75
9	50/26N	9.3	31	2	4.0	174	75
10	50/26QM	3.7	32	1	1.6	150	75
11	50/26QM	5.5	32	1	1.6	155	75
12	50/26QM	7.5	32	2	4.0	174	75
13	50/26QM	9.3	32	2	4.0	174	75
14	50/26Q	3.7	33	1	1.6	153	75
15	50/26Q	5.5	33	1	1.6	158	75
16	50/26Q	7.5	33	2	4.0	177	75
17	50/26Q	9.3	33	2	4.0	177	75
18	50/26QT	3.7	34	1	1.6	153	75
19	50/26QT	5.5	34	1	1.6	158	75
20	50/26QT	7.5	34	2	4.0	177	75
21	50/26QT	9.3	34	2	4.0	177	75
22	50/26NB	3.7	35	1	1.6	150	75
23	50/26NB	5.5	35	1	1.6	155	75
24	50/26NB	7.5	35	2	4.0	174	75
25	50/26NB	9.3	35	2	4.0	174	75
26	50/26QMB	3.7	36	1	1.6	150	75
27	50/26QMB	5.5	36	1	1.6	155	75
28	50/26QMB	7.5	36	2	4.0	174	75
29	50/26QMB	9.3	36	2	4.0	174	75
30	80/26N	7.5	41	2	4.0	194	105
31	80/26N	9.3	41	2	4.0	194	105
32	80/26N	11	41	2	4.0	200	105
33	80/26N	15	41	3	4.5	240	105
34	80/26N	18.5	41	2	4.5	240	105
35	80/26N	22	41	3	4.5	250	105
36	80/26QM	7.5	42	2	4.0	194	105

Sr. No.	Pump Model	Kw	Size Code	Unit	Oil Quantity (Liters)	Approx. Pump Weight (Kg.)	Connector unit Weight (Kg.)
37	80/26QM	9.3	42	2	4.0	194	105
38	80/26QM	11	42	2	4.0	200	105
39	80/26QM	15	42	3	4.5	240	105
40	80/26QM	18.5	42	2	4.5	240	105
41	80/26QM	22	42	3	4.5	250	105
42	80/26Q	7.5	43	2	4.0	197	105
43	80/26Q	9.3	43	2	4.0	197	105
44	80/26Q	11	43	2	4.0	203	105
45	80/26Q	15	43	3	4.5	245	105
46	80/26Q	18.5	43	2	4.5	245	105
47	80/26Q	22	43	3	4.5	255	105
49	80/26QT	9.3	44	2	4.0	197	105
50	80/26QT	11	44	2	4.0	203	105
51	80/26QT	15	44	3	4.5	245	105
52	80/26QT	18.5	44	2	4.5	245	105
53	80/26QT	22	44	3	4.5	255	105
54	100/26N	7.5	51	2	4.0	214	125
55	100/26N	9.3	51	2	4.0	214	125
56	100/26N	11	51	2	4.0	220	125
57	100/26N	15	51	3	4.5	263	125
58	100/26N	18.5	51	2	4.5	263	125
59	100/26N	22	51	3	4.5	273	125
60	100/26QM	7.5	52	2	4.0	214	125
61	100/26QM	9.3	52	2	4.0	214	125
62	100/26QM	11	52	2	4.0	220	125
63	100/26QM	15	52	3	4.5	263	125
64	100/26QM	18.5	52	2	4.5	263	125
65	100/26QM	22	52	3	4.5	273	125
66	100/26Q	7.5	53	2	4.0	217	125
67	100/26Q	9.3	53	2	4.0	217	125
68	100/26Q	11	53	2	4.0	223	125
69	100/26Q	15	53	3	4.5	267	125
70	100/26Q	18.5	53	2	4.5	267	125
71	100/26Q	22	53	3	4.5	277	125
72	100/26QT	7.5	54	2	4.0	217	125
73	100/26QT	9.3	54	2	4.0	217	125
74	100/26QT	11	54	2	4.0	223	125
75	100/26QT	15	54	3	4.5	267	125
76	100/26QT	18.5	54	2	4.5	267	125
77	100/26QT	22	54	3	4.5	277	125
78	150/26N	11	61	2	4.0	250	160
79	150/26N	15	61	3	4.5	287	160
80	150/26N	18.5	61	2	4.5	287	160

Sr. No.	Pump Model	Kw	Size Code	Unit	Oil Quantity (Liters)	Approx. Pump Weight (Kg.)	Connector unit Weight (Kg.)
81	150/26N	22	61	3	4.5	297	160
82	150/26QM	11	62	2	4.0	250	160
83	150/26QM	15	62	3	4.5	287	160
84	150/26QM	18.5	62	2	4.5	287	160
85	150/26QM	22	62	3	4.5	297	160
86	150/26Q	11	63	2	4.0	255	160
87	150/26Q	15	63	3	4.5	292	160
88	150/26Q	18.5	63	2	4.5	292	160
89	150/26Q	22	63	3	4.5	302	160
90	150/26QT	11	64	2	4.0	255	160
91	150/26QT	15	64	3	4.5	292	160
92	150/26QT	18.5	64	2	4.5	292	160
93	150/26QT	22	64	3	4.5	302	160
94	150/26NB	11	65	2	4.0	245	160
95	150/26NB	15	65	3	4.5	287	160
96	150/26NB	18.5	65	2	4.5	287	160
97	150/26NB	22	65	3	4.5	297	160
98	150/26QMB	11	66	2	4.0	245	160
99	150/26QMB	15	66	3	4.5	287	160
100	150/26QMB	18.5	66	2	4.5	287	160
101	150/26QMB	22	66	3	4.5	297	160
102	150/26NM	11	67	2	4.0	255	160
103	150/26NM	15	67	3	4.5	290	160
104	150/26NM	18.5	67	2	4.5	290	160
105	150/26NM	22	67	3	4.5	300	160
106	150/26QN M	11	68	2	4.0	255	160
107	150/26QN M	15	68	3	4.5	290	160
108	150/26QN M	18.5	68	2	4.5	290	160
109	150/26QN M	22	68	3	4.5	300	160
110	40/32QT	2.2	74	1	2.0	150	75
111	40/32QT	3.7	74	1	2.0	150	75
112	40/32QT	5.5	74	1	2.0	155	75
113	50/32N	7.5	81	2	5.5	194	75
114	50/32N	9.3	81	2	5.5	194	75
115	50/32N	11	81	2	5.5	200	75
116	50/32N	15	81	3	6.0	234	75
117	50/32N	18.5	81	2	6.0	234	75
118	50/32N	22	81	3	6.0	244	75
119	50/32QM	7.5	82	2	5.5	194	75
120	50/32QM	9.3	82	2	5.5	194	75
121	50/32QM	11	82	2	5.5	200	75

Sr. No.	Pump Model	Kw	Size Code	Unit	Oil Quantity (Liters)	Approx. Pump Weight (Kg.)	Connector unit Weight (Kg.)
122	50/32QM	15	82	3	6.0	234	75
123	50/32QM	18.5	82	2	6.0	234	75
124	50/32QM	22	82	3	6.0	244	75
125	50/32QT	7.5	84	2	5.5	199	75
126	50/32QT	9.3	84	2	5.5	199	75
127	50/32QT	11	84	2	5.5	205	75
128	50/32QT	15	84	3	6.0	239	75
129	50/32QT	18.5	84	2	6.0	239	75
130	50/32QT	22	84	3	6.0	249	75
131	65/32N	7.5	91	2	5.5	204	90
132	65/32N	9.3	91	2	5.5	204	90
133	65/32N	11	91	2	5.5	210	90
134	65/32N	15	91	3	6.0	244	90
135	65/32N	18.5	91	2	6.0	244	90
136	65/32N	22	91	3	6.0	254	90
137	65/32QM	7.5	92	2	5.5	204	90
138	65/32QM	9.3	92	2	5.5	204	90
139	65/32QM	11	92	2	5.5	210	90
140	65/32QM	15	92	3	6.0	244	90
141	65/32QM	18.5	92	2	6.0	244	90
142	65/32QM	22	92	3	6.0	254	90
143	65/32Q	7.5	93	2	5.5	209	90
144	65/32Q	9.3	93	2	5.5	209	90
145	65/32Q	11	93	2	5.5	215	90
146	65/32Q	15	93	3	6.0	250	90
147	65/32Q	18.5	93	2	6.0	250	90
148	65/32Q	22	93	3	6.0	260	90
149	65/32QT	7.5	94	2	5.5	209	90
150	65/32QT	9.3	94	2	5.5	209	90
151	65/32QT	11	94	2	5.5	215	90
152	65/32QT	15	94	3	6.0	250	90
153	65/32QT	18.5	94	2	6.0	250	90
154	65/32QT	22	94	3	6.0	260	90
155	65/32NB	7.5	95	2	5.5	202	90
156	65/32NB	9.3	95	2	5.5	202	90
157	65/32NB	11	95	2	5.5	208	90
158	65/32NB	15	95	3	6.0	242	90
159	65/32NB	18.5	95	2	6.0	242	90
160	65/32NB	22	95	3	6.0	252	90
161	65/32QMB	7.5	96	2	5.5	202	90
162	65/32QMB	9.3	96	2	5.5	202	90
163	65/32QMB	11	96	2	5.5	208	90
164	65/32QMB	15	96	3	6.0	242	90
165	65/32QMB	18.5	96	2	6.0	242	90

Sr. No.	Pump Model	Kw	Size Code	Unit	Oil Quantity (Liters)	Approx. Pump Weight (Kg.)	Connector unit Weight (Kg.)
		5					
166	65/32QMB	22	96	3	6.0	252	90
167	100/32N	11	A1	2	5.5	245	125
168	100/32N	15	A1	3	6.0	284	125
169	100/32N	18.5	A1	2	6.0	284	125
170	100/32N	22	A1	3	6.0	294	125
171	100/32QM	11	A2	2	5.5	245	125
172	100/32QM	15	A2	3	6.0	284	125
173	100/32QM	18.5	A2	2	6.0	284	125
174	100/32QM	22	A2	3	6.0	294	125
175	100/32Q	11	A3	2	5.5	250	125
176	100/32Q	15	A3	3	6.0	289	125
177	100/32Q	18.5	A3	2	6.0	289	125
178	100/32Q	22	A3	3	6.0	299	125
179	100/32QT	11	A4	2	5.5	250	125
180	100/32QT	15	A4	3	6.0	289	125
181	100/32QT	18.5	A4	2	6.0	289	125
182	100/32QT	22	A4	3	6.0	299	125
183	150/32N	18.5	B1	2	6.0	298	160
184	150/32N	22	B1	3	6.0	308	160
185	150/32QM	18.5	B2	2	6.0	298	160
186	150/32QM	22	B2	3	6.0	308	160
187	150/32Q	18.5	B3	2	6.0	303	160
188	150/32Q	22	B3	3	6.0	313	160
189	150/32QT	18.5	B4	2	6.0	303	160
190	150/32QT	22	B4	3	6.0	313	160
191	50/36QM	11	C2	2	6.5	215	75
192	50/36QM	15	C2	3	7.0	249	75
193	50/36QM	18.5	C2	2	7.0	249	75
194	50/36QM	22	C2	3	7.0	259	75
195	80/40N	18.5	D1	2	9.0	287	105
196	80/40N	22	D1	3	9.0	297	105
197	80/40QM	18.5	D2	2	9.0	287	105
198	80/40QM	22	D2	3	9.0	294	105
199	80/40Q	22	D3	3	9.0	300	105
200	80/40Q	18.5	D3	2	9.0	292	105
201	80/40QT	18.5	D4	2	9.0	292	105
202	80/40QT	22	D4	3	9.0	300	105
203	80/40NM	18.5	D7	2	9.0	290	105

Sr. No.	Pump Model	Kw	Size Code	Unit	Oil Quantity (Liters)	Approx. Pump Weight (Kg.)	Connector unit Weight (Kg.)
		5					
204	80/40NM	22	D7	3	9.0	300	105
205	80/40QNM	18.5	D8	2	9.0	290	105
206	80/40QNM	22	D8	3	9.0	300	105

Chart (6)

6. OVERHAULING:

Overhauling of the pump or any part of it, at site, is not permitted. In case of doubt, please consult our service division.

7. CROSS SECTIONAL DRAWING

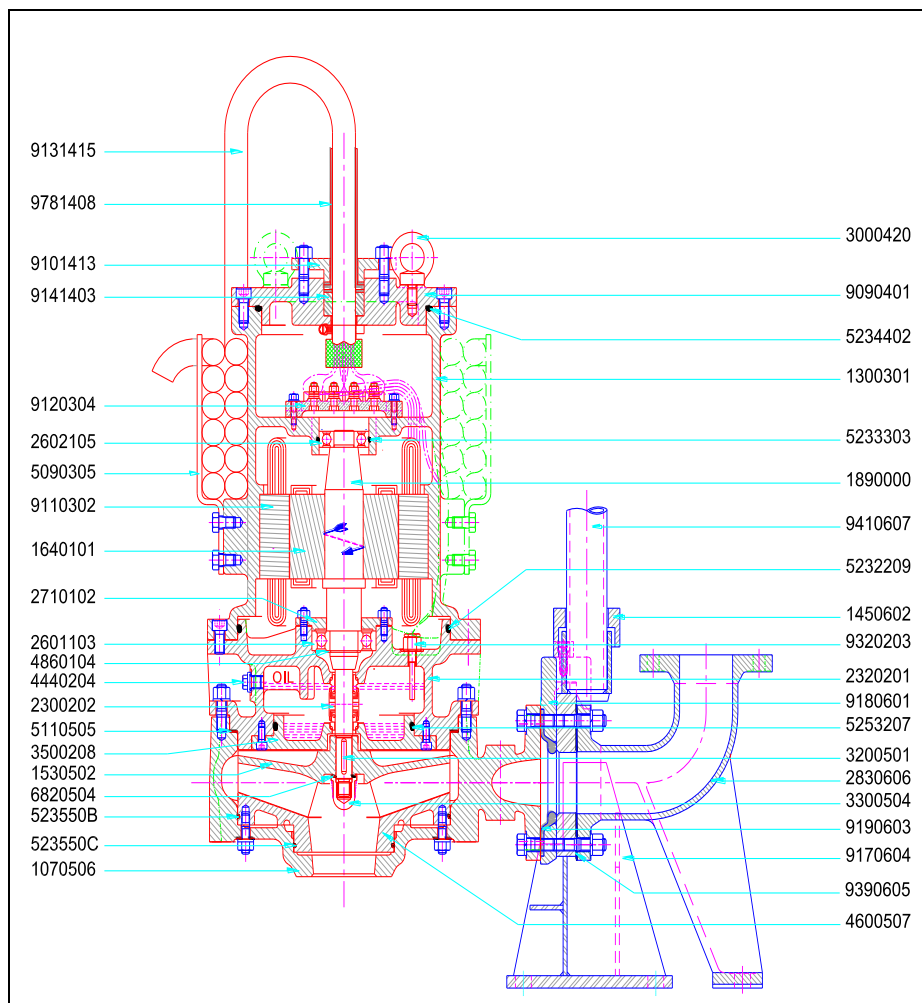

iNS PUMP PART LIST

PART CODE	PART DESCRIPTION	SUB ASSEMBLY	SUB UNIT
1640101	ROTOR WITH SHAFT & SPACER	SHAFT UNIT	MOTOR UNIT
2710102	BEARING COVER		
2600103*	LOWER BEARING		
4860104	CIRCLIP FOR BEARING		
2600105*	UPPER BEARING		
5250106*	O RING FOR UPPER BEARING		
5900151	STUD FOR BEARING COVER		
5860161	NUT FOR BEARING COVER		
7500171	SPRING WASHER FOR BEARING COVER		
2320201	MECHANICAL SEAL HOUSING	MECHANICAL SEAL HOUSING	
2300202*	MECHANICAL SEAL		
9320203*	MOISTURE SENSOR		
4440204	PLUG		
5250205*	O-RING FOR PLUG		
5250206*	O-RING FOR MOISTURE SENSOR		
5250207*	O RING FOR STUFFING BOX BUSH		
3500208*	STUFFING BOX BUSH		
5230209*	O-RING FOR MECHANICAL SEAL HOUSING		
5900251	STUD FOR MECH. SEAL HOUSING & STATOR HOUSING		
5900252	STUD FOR MECH. SEAL HOUSING & PUMP CASING		
6660253	HEX SOC CAP SCREW FOR STUFFING BOX BUSH-M8		



PART CODE	PART DESCRIPTION	SUB ASSEMBLY	SUB UNIT
6300254	RELEASE FOR MECH. SEAL HOUSING & STATOR HOUSING		
6300255	RELEASE FOR MECH. SEAL HOUSING & PUMP CASING		
5860261	NUT FOR MECH. SEAL HOUSING & STATOR HOUSING		
5860262	NUT FOR MECH. SEAL HOUSING & PUMP CASING		
7500271	SPRING WASHER FOR MECH. SEAL HSG. & STATOR HSG.		
7500272	SPRING WASHER FOR MECH. SEAL HOUSING & PUMP CASING		
1300301	STATOR HOUSING		
9110302	STATOR		
5230303*	O-RING STATOR HOUSING		
9120304	TERMINAL BOARD		
5090305	CABLE BRACKET		
6660351	HEX SOC CAP SCREW FOR TERMINAL BOARD		
5900352	STUD FOR TERMINAL BOARD & STATOR HSG.	STATOR HOUSING	
6660353	HEX SOC CAP SCREW FOR STATOR HSG & MOTOR END COVER		
6300354	RELEASE FOR STATOR HSG. & MOTOR END COVER		
7140355	HEX SCREW FOR CABLE BRACKET		
5860361	NUT FOR TERMINAL BOARD		
5860362	NUT FOR TERMINAL BOARD & STATOR HSG.		
8450371	WASHER FOR TERMINAL BOARD		
8450372	WASHER FOR TERMINAL BOARD & STATOR HSG.		
9090401	MOTOR END COVER		
5230402*	O RING MOTOR END COVER		
9140403*	CABLE SEAL FOR POWER		
9140404*	CABLE SEAL FOR POWER & CONTROL		
8450406*	WASHER FOR CABLE SEAL POWER		
8450407*	WASHER FOR CABLE SEAL POWER & CONTROL		
9780408*	CABLE PROT TUBE POWER		
9780409*	CABLE PROT TUBE POWER & CONTROL		
8450411*	WASHER FOR PROTECTION TUBE POWER		
8450412*	WASHER FOR PROTECTION TUBE POWER & CONTROL		
9100413	CABLE GLAND FOR POWER	MOTOR END COVER	
9100414	CABLE GLAND FOR POWER & CONTROL		
9130415	POWER CABLE		
9130416	POWER & CONTROL CABLE		
4930417*	HOSE CLIP		
4400418	POTTING CUP POWER		
4400419	POTTING CUP FOR POWER & CONTROL		
3000420	EYE BOLT		
5900451	STUD FOR CABLE GLAND		
5860461	NUT CABLE GLAND		
8850481	CRIMPING RING - PIN TYPE		
8850482	CRIMPING RING - RING TYPE		
3200501	KEY		
1510502	IMPELLER		
3300503*	IMPELLER NUT WITH INSERT/IMPELLER SCREW WITHOUT INSERT		
6820504*	GASKET FOR IMPELLER		
5110505*	GASKET FOR PUMP CASING		
1070506	PUMP CASING		
1900507	SUCTION PLATE/WEAR PLATE/CASING RING*	PUMP	PUMP UNIT
3410508	TIE BAR FOR STAND		
3830509	SUPPORT PLATE FOR STAND		
209050A*	SPACER-SUC PLATE		
523050B	O-RING FOR SUCTION PLATE/WEAR PLATE		
523050B*	O-RING FOR WEAR PLATE		
5900551	STUD FOR SUCTION PLATE/ WEAR PLATE/ GRUB SCREW FOR CASING RING		

PART CODE	PART DESCRIPTION	SUB ASSEMBLY	SUB UNIT
5860562	NUT FOR SUCTION PLATE/ WEAR PLATE		
5860561	NUT FOR STAND		
7500571	SPRING WASHER FOR STAND		
4790581	HELICOIL INSERT		
9180601	GUIDE SHOE	CONNECTOR UNIT FOR STATIONARY INSTALLATION	
1450602	GUIDE PIPE ADAPTER		
9190603*	RUBBER DIAPHRAGM		
9170604	SUPPORT BRACKET		
9390605*	GASKET FOR BEND		
2830606	DUCK FOOT BEND		
9410607	GUIDE PIPE		
9210608	GUIDE PIPE HOLDER		
5590609	ADAPTER PIECE		
3040651	FOUNDATION BOLTS		
5860061	NUT FOR FOUNDATION BOLTS		
8450071	WASHER FOR FOUNDATION BOLTS		
5900052	STUD FOR BEND & CASING		
5860062	NUT FOR BEND & CASING		
7500072	SPRING WASHER FOR BEND & CASING		
5900053	STUD FOR SUPPORT BRACKET & GUIDE SHOE		
5860063	NUT FOR SUPPORT BRACKET & GUIDE SHOE		
7500073	SPRING WASHER FOR SUPPORT BRACKET & GUIDE SHOE		
6660281	HEX SOC CAP SCREW FOR GUIDE PIPE ADAPTER		

Chart (7)

* Marked part code nos. is recommended spares.

10. SPARE PARTS

SPARE PARTS

A set of ball bearings, a set of casing rings, and a set of gland packing rings must always be kept at hand to ensure uninterrupted service from the pump. While ordering for spare parts, always give type, size and serial number of the pumps as stamped on the name plate.

11.

PUMP TROUBLE

When investigating trouble with Kirloskar pumps, always remember that pumps have been tested at the factory and are mechanically correct when sent out. Discounting the possibility of damage during transit, most of the trouble in the field is due to faulty installation. Investigation shows that the majority of troubles with centrifugal pumps result from faulty conditions on the suction side.

BREAK DOWN-CAUSE-CHECK POINTS

In case of breakdown we recommend the location of the fault by using the following table.

BREAKDOWN	CHECK POINTS									
Pump does not deliver	1	7	8	9	10	11	12	14	15	17
	18	19	23	25	26	56	57	58		
Pump delivers at reduced capacity	1	2	3	4	5	6	7	8	9	10
	11	12	13	14	15	17	18	19	20	21
Delivery performance deteriorates	1	3	7	9	10	11	12	13	14	19
	20	21	22	23	24	53	57	62		
Pump delivers too much	16	56	57	58						
Delivery is interrupted	1	3	6	7	8	9	10	11	12	13
	14	15	16	18	22	23	25	26	56	57
After stopping pump runs in reverse direction	52									
Very noisy	1	2	5	6	7	8	11	12	13	15
	19	20	22	54	55	56	57	62		
Unsteady running of pump	19	20	22	31	32	33	36	36	37	38
	39	40	43	44	47	48	49	50	51	54
Stuffing box leaks excessively	24	27	28	29	30	31	47	48	49	53
	22	23	24	25	26	27	28	29	30	41
Fumes from stuffing box	42	43								
Pump rotor locked in standstill position	22	45	46	50						
Pump is heating up and seizing	23	24	25	26	27	28	29	30	40	41
	42	45	47	48	49	50	54			
Bearing temperature increases	19	20	21	22	31	32	33	34	35	36
	37	38	39	40	41	42	43	44	45	46
Motor will not start	14	22	60							
Motor gets hot or burns out	14	22	27	28	40	43	50	55	56	57
	58	59	60	61						
Motor is difficult to start	14	22	27	28	45	46	50	58	59	60

CHECK POINTS

1. Suction pipe, foot valve choked.
2. Nominal diameter of suction line too small.
3. Suction pipe not sufficiently submerged.
4. Too many bends in the suction line.
5. Clearance around suction inlet not sufficient.
6. Shut off valve in the suction line in unfavourable position.
7. Incorrect layout of suction line (formation of air pockets).
8. Valve in the suction line not fully open.
9. Joints in the suction line not leak-proof.
10. Air leaking through the suction line and stuffing box etc.
11. Suction lift too high.
12. Suction head too low (difference between pressure at suction connection and vapour pressure too low).
13. Delivery liquid contains too much gas and/or air.
14. Delivery liquid too viscous.
15. Insufficient venting.
16. Number of revolutions too high.
17. Number of revolutions too low.
18. Incorrect direction of rotation (electric motor incorrectly connected, leads of phases on the terminal block interchanged).
19. Impeller clogged.
20. Impeller damaged.
21. Casing rings worn out.
22. Separation of crystals from the flow of pumping liquid (falling below the temperature limit/equilibrium temp).
23. Sealing liquid line obstructed.
24. Sealing liquid contaminated.
25. Lantern ring in the stuffing box is not positioned below the sealing liquid inlet.
26. Sealing liquid omitted.
27. Packing incorrectly fitted.
28. Gland tightened too much/slanted.
29. Packing not suitable for operating conditions.
30. Shaft sleeve worn in the region of the packing.
31. Bearing worn out.
32. Specified oil level not maintained.
33. Insufficient lubrication of bearings.
34. Ball bearings over-lubricated.
35. Oil/Grease quality unsuitable.
36. Ball bearing incorrectly fitted.
37. Axial stress on ball bearings (no axial clearance for rotor).
38. Bearings dirty.
39. Bearings rusty (corroded).
40. Axial thrust too great because of worn casing rings, relief holes obstructed.
41. Insufficient cooling water supply to stuffing box cooling.
42. Sediment in the cooling water chamber of the stuffing box cooling.
43. Alignment of coupling faulty or coupling loose.
44. Elastic element of coupling worn.
45. Pump casing under stress.
46. Pipeline under stress.
47. Shaft runs untrue.
48. Shaft bent.
49. Rotor parts insufficiently balanced.
50. Rotor parts touching the casing.
51. Vibration of pipe work.
52. Non-return valve gets caught.
53. Contaminated delivery liquid.
54. Obstruction in delivery line.
55. Delivery flow too great.
56. Pump unsuitable for parallel operation.
57. Type of pump unsuitable.
58. Incorrect choice of pump for existing operating conditions.
59. Voltage too low/power supply overloaded.
60. Short circuit in the motor.
61. Setting of starter of motor too high.
62. Temperature delivery liquid too high.

12. GENERAL INFORMATION & SAFETY INSTRUCTIONS

- 12.1.1 The products supplied by KBL have been designed with safety in mind. Where hazards cannot be eliminated, the risk has been minimized by the use of guards and other design features. Some hazards cannot be guarded against and the instructions below **MUST BE COMPLIED WITH** for safe operation. These instructions cannot cover all circumstances. Installation, operation and maintenance personnel must use safe working practices at all the times.
- 12.1.2 KBL products are designed for installation in designated areas, which are to be kept clean and free of obstructions that may restrict safe access to the controls and maintenance access points.
- 12.1.3 A pump duty nameplate is fitted to each unit and must not be removed. Loss of this plate could make identification impossible. This in turn could affect safety and cause difficulty in obtaining spare parts. If accidental loss or damage occurs, contact KBL immediately.
- 12.1.4 Access to the equipment should be restricted to the person net responsible for installation, operation and maintenance and they must be trained, adequately qualified and supplied with appropriate tools for their respective tasks.
- 12.1.5 Most accidents involving product operation, maintenance and repair are caused by failure to observe safety rules or precautions. An accident can often be avoided by recognizing potentially situations before an accident occurs. A person must be aware of potential hazard associated in activities of installation, operation and maintenance of equipments.
- 12.1.6 KBL requires that, all personnel that are responsible for installation, operation or maintenance of the equipment, have access to and study the product instruction manual **BEFORE** any work is done and that they will comply with all local and industry based safety instructions and regulations
- 12.1.7 Ear defenders should be worn where the specified equipment noise level exceeds locally defined safe levels. Safety glasses or goggles or face shield should be worn where working with pressurized systems and hazardous substances. Other personal protection equipment must be worn where local rules apply. Wear safety shoes, helmets and cotton overall [Apron] when you enter pump house. Noise level should not exceed 90 dbA and 110 dbA for motor driven and engine driven pumps, respectively.
- 12.1.8 Do not wear loose clothing or jewelry, which could catch on the controls or become trapped in the equipment
- 12.1.9 Read the instruction manual before installation, operation or maintenance of the equipment. Check and confirm that you are referring relevant copy of the manual by comparing pump type on the nameplate and with that on the manual.
- 12.1.10 **Note the “Limits of product application permissible use” specified in the manual. Operation of the equipment beyond these limits will increase the risk from hazards noted below and may lead to premature and hazardous pump failure.**
- 12.1.11 Clear and easy access to all controls, gauges and dials etc must be maintained at all times. Hazardous or flammable materials must not be stored in pump rooms unless safe areas or racking and suitable container have been provided.
- 12.1.12 Use suitable earthing and tripping devices for electrical equipments.
- 12.1.13 IMPROPER INSTALLATION, OPERATION, MAINTENANCE,
- 12.1.14 LUBRICATION, REPAIR OF THIS KBL PRODUCT COULD
- 12.1.15 RESULT IN INJURY OR DEATH.

12.2.1 SAFETY INSTRUCTIONS WHILE HANDLING

When lifting the pump, use the lifting points specified on general arrangement drawing, if provided. Use lifting equipment having a safe working load rating suitable for the weight specified. Use suitable slings for lifting pump, which is not provided, with lifting points. The use of forklift truck and chain crane sling equipment is recommended but locally approved equipment of suitable rating may be used. While lifting, the equipment adjusts the center of gravity, so that it is balanced properly.

Do not place fingers or hands etc into the suction or discharge pipe outlets and do not touch the impeller, if rotated this may cause severe injury. To prevent ingress of any objects, retain the protection covers or packaging in place until removal is necessary for installation. If the packaging or suction and discharge covers are removed for inspection purposes, replace afterwards to protect the pump and maintain safety.

12.2.2 STORAGE

12.2.2.1 Temporary storage for up to six weeks.

If the pump unit is not be used immediately it should be stored carefully in a horizontal position, in a sheltered, dry location. Additional rust preventive should be applied to all unpainted carbon steel or cast iron parts, and should not be removed until final installation.

12.2.2.2 Long Term Storage.

If the pump is not to be installed and operated soon after arrival, store it in a clean, dry place, having slow, moderate changes in ambient temperature. Step should be taken to protect the pump from moisture, dust, dirt, and foreign bodies. It is recommended that the following procedure is taken:-

- a) Ensure that the bearings are packed with the recommended grease, to prevent moisture from entering around the shaft.
- b) Remove the glands, packings and lantern rings from the stuffing box if the pump is equipped in this manner.** If the pump is equipped with mechanical seal, dismantle and coat the seal with light oil.
- c) Ensure that suction and discharge branches of the pump and all other openings are covered with cardboard, wood or masking tape to prevent foreign objects entering the pump.
- d) If the pump is to be stored where there is no protective covering, it is advisable to cover the unit with a tarpaulin or other suitable covering.
- e) The shaft should be manually rotated periodically to prevent pitting of the bearing surfaces by moisture.



Shearing Hazard.

Do NOT place fingers or hands etc. into the suction or discharge pipe outlets and do NOT touch the impeller, if rotated this may cause severe injury. To prevent ingress of any objects, retain the protection covers or packaging in place until removal is necessary for installation. If the packaging or suction and discharge covers are removed for inspection purposes, replace afterwards to protect the pump and maintain the safety.

Fill the bearing housing with recommended grease to ensure that the shaft and bearings remain rust free.

12.2.2.3 Exposed or Extreme Conditions Storage.

For exposed storage or extreme variants in atmospheric or environmental conditions, please refer to KBL for special storage instructions to suit the conditions acceptable.

12.2.3 SAFETY INSTRUCTIONS WHILE ASSEMBLY & INSTALLATION

If hot liquids [above 80°C] are being pumped, alignment should be checked and reset with the pump and motor at their normal operating temperature. If this is not possible, KBL can supply estimated initial offset figures to suit extreme operating temperatures. Failure to support suction and delivery pipe work may result in distortion of the pump casing, with the possibility of early pump failure.

12.2.4 SAFETY INSTRUCTIONS WHILE COMMISSIONING & OPERATION

Never attempt adjustments while the pump is running, unless otherwise specified in the operation, maintenance manual.

Do not touch any moving or rotating parts. Guards are provided to prevent access to these parts, where they have been removed for maintenance they must be replaced before operating the equipment.

Check that pump is primed. Pump should never be run dry as the pumped liquid acts as lubricant for the close running fits surrounding impeller and damage will be incurred.

Failure to supply the stuffing box or mechanical seal with cooling or flush water may result in damage and premature failure of the pump.

Do not touch surfaces, which during normal running will be sufficiently hot to cause injury. Note that these surfaces remain hot after the pump has stopped, allow sufficient time for cooling before maintenance. Be cautious and note that other parts of the pump may become hot if a fault is developing.

Do not operate water pumps in temperatures below freezing point, without first checking that the pumped fluid is not frozen and the pump is free to turn. Pumps in these environments should be drained down during inactivity and re-primed before starting.

In addition to local or site regulations for noise protection, KBL recommend the use of personal ear protection equipment in all enclosed pump rooms and particularly those containing diesel engines. Care must be taken to ensure that any audible alarm or warning signal can be heard with ear defenders worn.

Be aware of the hazards relating to the pump fluid, especially the danger from inhalation of noxious and toxic gases, skin and eye contact or penetration. Obtain and understand the hazardous substance data sheets relating to the pumped fluid and note the recommended emergency and first aid procedures.

12.2.5 SAFETY INSTRUCTIONS WHILE MAINTENANCE & SERVICING

Do not attempt repairs of the pump or its accessories which you do not know. Use proper tools.

Before attempting any maintenance on a pump particularly if it has been handling any form of hazardous liquid, it should be ensured that the unit is safe to work on. The pump must be flushed thoroughly with suitable cleaner to purge away any of the product left in the pump components.

This should be carried out by the plant operator and a certificate of cleanliness obtained before starting work. To avoid any risk to health it is also advisable to wear protective clothing as recommended by the site safety officer especially when removing old packing, which may be contaminated.

Isolate the equipment before any maintenance work is done. Switch off the main supply, remove fuses, apply lockouts where applicable and affix suitable isolation warning signs to prevent inadvertent reconnection. In order to avoid the possibility of maintenance personnel inhaling dangerous fumes or vapors locations by removal of bearing housing and shaft assembly to a suitable maintenance area.

Check and ensure that the pump operates at below the maximum working pressure specified in the manual or on the pump nameplate and before maintenance, ensure that the pump is drained down.

Wear a suitable mask or respirator when working with packing and gasket contain fibrous material, as these can be hazardous when the fibrous dust is inhaled. Be cautious, if other supplier's components have been substituted for genuine KBL parts, these may then contain hazardous materials.

Store all oily rags or other flammable material in a protective container in a safe place.

Do not weld or flame cut on pipes/tubes that contents flammable fluids. Clean them thoroughly with nonflammable solvent before welding or flame cutting on them. Use solvent/chemical resistant gloves for hand protection.

Adequacy of suitable crane should be checked before lifting the pump/pump components. Also condition of pulleys, chain and lifting shackles should be checked before use.

13. ENVIRONMENTAL ASPECTS:

Our products are designed and manufactured considering all environmental aspects to minimize impact on the environment. We ensure that the product supplied by us utilizes less energy during their life cycle and it does not emit any hazardous gas or cause any harm to any living being or to the environment. User of this product is recommended to follow the operating instructions and maintain the product in periodic manner, in order to ensure that it always functions with optimum energy efficiency.

Product Recycle Program

As a commitment towards a greener future, conservation of natural resources and reduction of carbon foot print, Kirloskar Brothers Limited offers to take back/replace its used products once it has reached the end-of-life and ensure that it is recycled/ disposed in an environment friendly manner with the following objective.

- To facilitate our customers for recycling / safe disposal of „end -of-life product in environment friendly through a recycle program.
- To minimize the impact caused by product disposal on society / environment.
- To reuse the recyclable components as secondary source of raw material.
- To ensure implementation of control mechanism over third part for recycle/safe disposal of the waste generated.
- To offer or replace customer s existing product with more efficient and environment friendly product.

End of life of Kirloskar Brothers Limited product shall be considered, when a customer has declared that the product has become redundant (the product has become obsolete/unfit for use/non-functional and cannot be refurbished in consultation with Kirloskar Brothers Limited personnel) Or the customer wishes to replace the existing product for a shift in technology/for replacement of product by latest/advanced technology of more energy efficient friendly product. As the product reaches its End-of-Life, the customer shall communicate the same through the Kirloskar Brothers Limited mail ID, customercare.recycle@kbl.co.in or approach the nearest Customer Support Service/Regional Offices/ Authorized Dealer/Authorized Service Dealers who in turn shall communicate the same to Zonal Customer Support Service representative.



Enriching Lives

KIRLOSKAR BROTHERS LIMITED

A Kirloskar Group Company

Established 1888

GLOBAL HEADQUARTERS

“Yamuna”, S. No. 98/3 to 7, Baner, Pune - 411045, India
Phone: +91-20-27214444 Email: kblin@kbl.co.in

REGISTERED OFFICE

Udyog Bhavan, Tilak Road, Pune - 411002, India
Phone: +91-20-24440156 Fax: +91-24440156

GLOBAL PRESENCE

Cambodia | Egypt | India | Lao PDR | Senegal | South Africa | Thailand | The Netherlands
| United Arab Emirates | United Kingdom | United States of America | Vietnam

www.kirloskarpumps.com

OUR COMPANIES

				
United Kingdom	U.S.A.	South Africa	India	The Netherlands