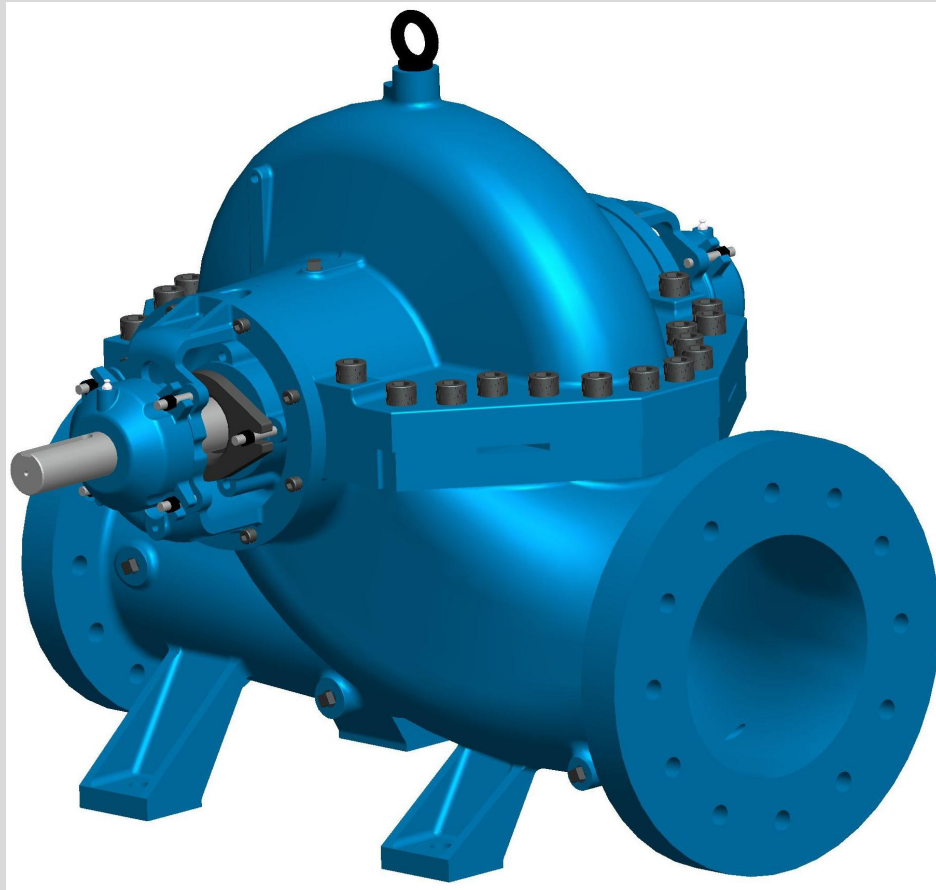


# **INSTRUCTION ON INSTALLTION, OPERATION & MAINTENANCE FOR KIRLOSKAR PUMP TYPE SCT**



**KIRLOSKAR BROTHERS LIMITED**

"Yamuna" S.No.98/3 to 7, Baner, Pune 411045



Enriching Lives

**KIRLOSKAR BROTHERS LIMITED**  
Udyog Bhavan, Tilak Road, Pune 411 002 (India)

## **WARRANTY**

We warrant that the pump supplied by us is free from defective material and faulty workmanship. This warranty holds good for a period of 12 months from the date of commissioning of the equipment or 18 months from the date of despatch from our factory, whichever is earlier. Our liability in respect of any complaint is limited to replacing part/parts free of charge ex-works or repairs of the defective part/parts only to the extent that such replacement / repairs are attributable to or arise solely from faulty workmanship or defective material.

The warranty holds good only for the products manufactured by us.

**KIRLOSKAR BROTHERS LIMITED**



## **CONTENTS**

- 1. GENERAL**
- 2. SAFETY INSTRUCTIONS**
- 3. INSTALLATION**
- 4. OPERATION**
- 5. TECHNICAL DATA**
- 6. MAINTENANCE**
- 7. OVERHAULING**
- 8. GENERAL OUTLINE DIMENSIONS**
- 9. SPARE PART LIST AND CROSS-SECTIONAL DRAWINGS**
- 10. EXPLODED VIEW.**

Please ensure these instructions are read fully before installation and operation of the pump.

Please furnish complete name plate details, part description, part nos, material construction and quantity while ordering spare parts.



## 1. GENERAL

### 1.1 The booklet covers instructions for following types of SCT pumps.

PUMP TYPE	MODULE NO.
SCT65/24	1
SCT80/24	1
SCT100/24	1
SCT125/24	1
SCT150/24	1
SCT125/29	1
SCT80/30	1
SCT100/30	1
SCT125/30	1
SCT80/38	1
SCT50/38	1
SCT150/30	2
SCT200/30	2
SCT250/24	2
SCT250/30	2
SCT100/38	2
SCT125/38	2
SCT150/38	2
SCT250/40	2
SCT200/38	3
SCT250/38	3
SCT150/48	3
SCT200/48	3
SCT200/48C & CDV	3

1.2 These are horizontal split casing type pumps with suction and discharge nozzles and their supporting feet integrally cast in the lower half casing. This construction enables to remove the rotating unit for inspection and repairs by just removing upper half casing, and without disturbing alignment, pipe connection or prime mover.

1.3 Pumps when properly installed and given due care in operation and maintenance should operate satisfactorily for a long period.

1.4 When the pump is received, sometime before the actual use of pump, it should be inspected and located in dry place. The coupling should be rotated periodically (once in a month) to prevent pitting of bearing surfaces.



- 1.5 Generally all the SCT pumps mentioned above are similar in construction with minor changes of some parts.
- 1.6 Pump Identification: All pumps are designated by serial number, model number, size and type. This information is stamped on an identification plate which is fixed on the pump.

### 1.7 Nomenclature of the pump

Nomenclature for pump is as given below.

#### **SCT 150/38**

**SCT**- Basic pump type

**150**- Nominal Delivery size in mm

**/** - Always slash

**38**- Nominal Impeller diameter in cm.

## **PUMP DESCRIPTION**

**Casing** - The casing is of axially-split volute design with suction and discharge flanges and mounting feet cast integral with the lower half casing. Tapped and plugged holes are provided for priming, vent, drain and gauge connections. Upper half casing is removable without disturbing suction or discharge piping.

Suction and Discharge is on a common centerline in both the horizontal and vertical planes.

**Impeller** - The impeller is of the enclosed double-suction (except SCT50/38 & SCT80/38 pumps), statically and hydraulically balanced. The impeller is keyed to the shaft and positioned axially by the shaft sleeves. Hub shall have sufficient metal thickness to allow machining for installation of casing wear rings.

**Shaft** - The shaft shall be of ample size to operate under load with of minimum deflection.

**Shaft Sleeves** - The shaft sleeves should protect the shaft from wear and from contact with the pumped liquid. An O-ring shall be furnished under sleeve to prevent leakage.



**Insert (Stuffing Box)** - The insert is consisting of at least six packing rings and a split type gland to permit removal and access to packing. Ample space is provided for repacking the insert.

**Bearings** - The bearings are grease lubricated or oil lubricated. The inboard or coupling end bearing is a single row ball bearing. The outboard bearing is a double row cylindrical roller bearing which is retained by bearing locknut and lock washer.

**Bearing Housings** - The bearing housings are bolted to the end of the lower half casing and assure positive alignment of the rotating element. The housings provides a fit for the inboard bearing that allows freedom for thermal expansion while the outboard bearing is clamped in place to take all thrust loads and keep the rotating element in its proper axial location.

**Base plate** - The base plate is sufficiently rigid to support the pump and driver and shall be provided with a drip pan beneath the pump. The drip pan contains a tapped drain connection.

**Coupling** - Coupling can be supplied – Snap-wrap / Pin-Bush / Spacer type

**Coupling Guard** - The coupling guard can be in MS / AL.

**Rotation** - Pump can have clockwise or counterclockwise rotation when viewed from its driving end.



## 2. SAFETY INSTRUCTIONS:

### 2.1: General Information

Before performing any actions detailed within this instruction, the Site Health and Safety instructions must read and fully understood. The instructions in this document also must be read and fully understood.

Whenever the equipment is operated, maintained or used in any way, the procedures detailed within the Health and Safety Dossier (DHS) and any procedures detailed within these instructions shall be followed. The pump supplied by Kirloskar Brothers Limited (KBL) has been designed with safety in mind, where hazards cannot be eliminated; the risk has been minimized by the use of guards and other design features. Some hazards cannot be guarded against and the instructions below **MUST BE COMPLIED WITH** for safe operation. These instructions cannot cover all circumstances. It is the responsibility of the user of the equipment for maintaining safe working practices at all times.

- 2.1.1 KBL products are designed for installation in designated areas, which are to be kept clean and free of obstructions that may restrict safe access to the controls and maintenance access points.
- 2.1.2 Pump nameplate is fitted to each unit and must not be removed. Loss of this plate could make identification impossible. This in turn could affect safety and cause difficulty in obtaining spare parts. Should accidental loss or damage occur, contact KBL immediately.
- 2.1.3 Access to the equipment should be restricted to the personnel responsible for installation, operation and maintenance and they must be trained, adequately qualified and supplied with the appropriate tools for their respective tasks.
- 2.1.4 KBL firmly insists that all personnel responsible for installation, operation and maintenance of the equipment must read [safety instructions](#) mentioned in the manual before any work is done.

- 2.1.5 Ear defenders should be worn where the specified equipment noise level exceeds locally defined safe levels. Safety glasses or goggles should be worn where working with pressurized systems and hazardous substances. Other personal protection equipment must be worn where local rules apply.
- 2.2 DO NOT wear loose or frayed clothing or jewellery, which could catch on the controls or becomes trapped in the equipment.
- 2.3 Operation of the equipment for the application other than for which it is supplied can increase the risk from hazards. Please consult KBL before making such change in the application of the equipment.
- 2.4 Improper installation, operation and maintenance of the product supplied by KBL could result in injury or death.
- 2.5 Within the manual, safety instructions are marked with safety symbols.

**Hazard**

This symbol refers to general mechanical aspects of safety.

**Hazard**

This symbol refers to electrical safety.

**2.6: Transport handling and storage instructions:****2.6.1: Transport**

Pumps are dispatched in duly assembled condition. Pumps are protected against corrosion and packed for transport by normal road, rail and sea carriers.

**2.6.2: Handling**

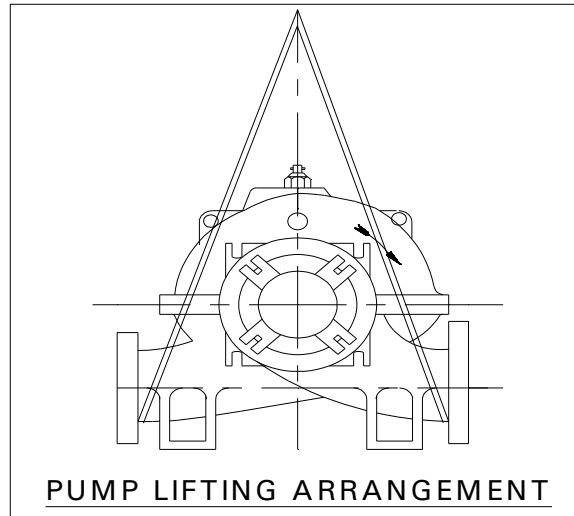
Crushing hazard



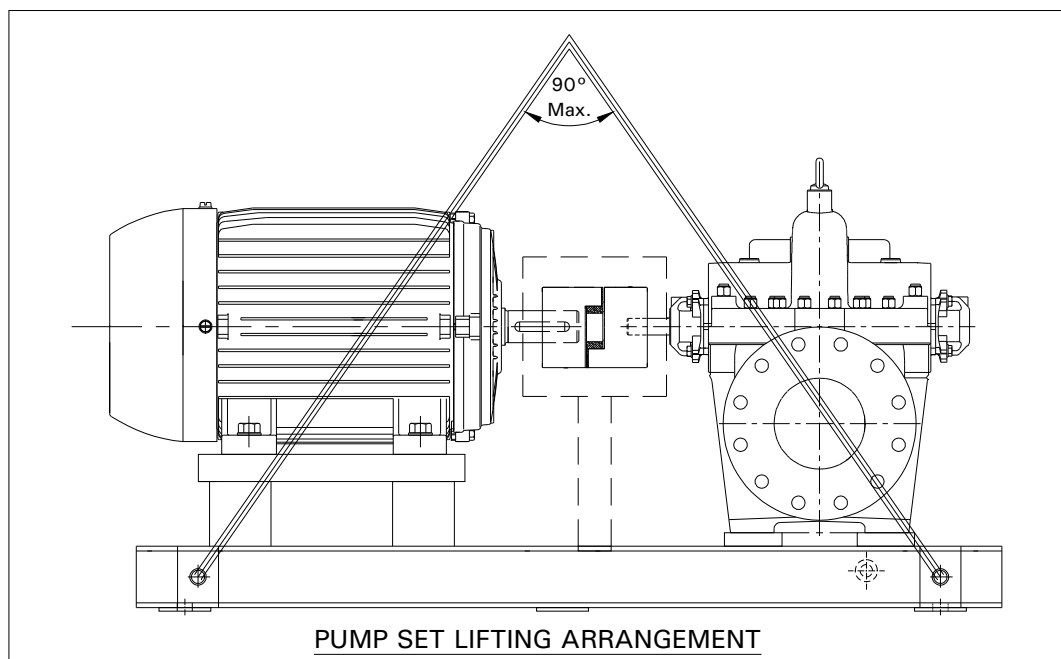
When lifting the pump or pump set, use lifting equipment having a safe working load rating suitable for the weight specified. Use suitable slings for lifting any pump not provided with lifting points.

The use of suitable forklift truck and four chain crane sling equipment is recommended but locally approved equipment rating may be used.

Pump should be slung as shown.



Pump set must be lifted from the lifting holes provided **on the pump** by using suitable four chain lifting equipment.



### 2.6.3: Storage.

#### 2.6.3.1: Temporary storage for up to six weeks.

If the pump unit is not be used immediately it should be stored carefully in a horizontal position, in a sheltered, dry location. Additional rust preventive should be applied to all unpainted carbon steel or cast iron parts, and should not be removed until final installation.

#### 2.6.3.2: Long Term Storage.

If the pump is not to be installed and operated soon after arrival, store it in a clean, dry place, having slow, moderate changes in ambient temperature. Step should be taken to protect the pump from moisture, dust, dirt, and foreign bodies. It is recommended that the following procedure is taken:-

- a) Ensure that the bearings are packed with the recommended grease, to prevent moisture from entering around the shaft.
- b) Remove the glands, packing's and lantern rings from the stuffing box if the pump is equipped in this manner. If the pump is equipped with mechanical seal, dismantle and coat the seal with light oil.
- c) Ensure that suction and discharge branches of the pump and all other openings are covered with cardboard, wood or masking tape to prevent foreign objects entering the pump.
- d) If the pump is to be stored where there is no protective covering, it is advisable to cover the unit with a tarpaulin or other suitable covering.
- e) The shaft should be manually rotated periodically to prevent pitting of the bearing surfaces by moisture.



Shearing Hazard.



Do NOT place fingers or hands etc. into the suction or discharge pipe outlets and do NOT touch the impeller, if rotated this may cause severe injury. To prevent ingress of any objects, retain the protection covers or packaging in place until removal is

necessary for installation. If the packaging or suction and discharge covers are removed for inspection purposes, replace afterwards to protect the pump and maintain the safety.

Fill the bearing housing with recommended grease to ensure that the shaft and bearings remain rust free.

#### 2.6.3.3: Exposed or Extreme Conditions Storage.

For exposed storage or extreme variants in atmospheric or environmental conditions, please refer to KBL for special storage instructions to suit the conditions acceptable.

### 3 INSTALLATIONS

#### 3.1 Receiving pump

Upon receipt of the pump, a visual check should be made to determine if any damage occurred during transit or handling. The main items to look for are:-

- a) Broken or cracked equipment, including base, motor or pump feet and flanges.
- b) Bent shaft
- c) Broken motor end bells, bent eyebolts or damaged boxes of motor
- d) Missing parts.
- e) Pump shaft rotates freely.

**Parts or accessories are some times wrapped individually or fastened to the equipment. If any damage or losses have been incurred; promptly notify your KBL representative, KBL Dealer and the transport company who delivered the pump.**



When unloading pump units, lift equally at four or more points from the base. DO NOTLIFT ONLY THE DRIVER OR PUMP.

### 3.2 Preparation

Before installing the pump, clean the suction and discharge flanges thoroughly.

Remove the protective coating from the pump shaft.

If the pump has been in storage and prepared for storage in the manner outlined previously, remove all the grease from the bearings. The bearings should then be flushed with carbon tetrachloride or kerosene and relubricated.

### 3.3 Location

The pump should be installed as near the suction supply as possible, with the shortest and most direct suction pipe practical. The total dynamic suction lift (static lift plus friction losses in suction line) should not exceed the limits for which the pump was sold.

The pump must be primed before starting. Whenever possible, the pump should be located below the fluid level to facilitate priming and assure a steady flow of liquid. This condition provides a positive suction head on the pump. It is also possible to prime the pump by pressurizing the suction vessel.

❖ Pumps must be fully primed at all times during operation.

When installing the pump, consider its location in relation to the system to assure that sufficient Net Positive Suction Head (NPSHA) is available at the pump inlet connection. Available NPSH must always equal or exceed the required NPSH (NPSHR) of the pump. The pump should be installed with sufficient accessibility for inspection and maintenance. A clear space with ample head room should be allowed for the use of an overhead crane or hoist sufficiently strong to lift the unit.

❖ **NOTE: Allow sufficient space to be able to dismantle pump without disturbing the pump inlet and discharge piping.**



Select a dry place above the floor level wherever possible. Take care to prevent pump from freezing during cold weather when not in operation. If the possibility of freezing exists during a shut-down period, the pump should be completely drained, and all passages and pockets where liquid might collect should be blown out with compressed air.

Make sure there is a suitable power source available for the pump driver. If motor driven, the electrical characteristics of the power source should be identical to those shown on motor data plate.

### **3.4 Foundation**

The foundation should be strong enough to reduce vibrations and rigid enough to avoid any twisting or misalignment.

The foundation should be poured without interruptions to within 20 to 40 mm of the finished height. The top surface of the foundation should be well scored and glued before the concrete sets. This provides a bonding surface for the grout. Foundation bolts should be set in concrete as shown in Fig. 1. Allow enough bolt length for grout, shims, lower base plate flange, nuts and washers. The foundation should be allowed to cure for several days before the base plate is shimmed and grouted.

### **3.5 Baseplate setting**

Use blocks and shims under base for support at foundation bolts and midway between bolts, to position base approximately 25 mm above the concrete foundation with studs extending through hole in the baseplate.

By adding or removing shims under the base, level the pump shaft and flanges. The baseplate does not have to be leveled. Draw foundation bolt nuts tight against baseplate and observe pump and motor shafts or coupling hubs for alignment.

Check to make sure the piping can be aligned to pump flanges without placing pipe strain on either flange.



Grout base plate in completely and allow grout to dry thoroughly before attaching piping to pump (24 hours is sufficient time with approved grouting procedure).

### 3.6 Grouting procedure

Grout compensates for uneven foundation, distributes weight of unit and prevents shifting. Use an approved, non-shrinking grout as follows, after setting and leveling unit See Fig. 2.

- a) Build strong form around foundation to contain grout.
- b) Soak top of concrete foundation thoroughly, then remove surface water.
- c) Base plate should be completely filled with grout and, if necessary, drill vent holes to remove trapped air.
- d) After grout has thoroughly hardened, check the foundation bolts and tighten if necessary.
- e) Check the alignment after the foundation bolts are tightened.
- f) Approximately 14 days after the grout has been poured or when the Grout has thoroughly dried, apply an oil base paint to the exposed edges of the grout to prevent air and moisture from coming in contact with the grout.

### 3.7 Alignment procedure

The pump driver, if supplied, is correctly aligned on its base plate at the factory. A certain amount of deformation of the base plate is possible during transit and it is therefore essential to check alignment, prior to final grouting.

**A flexible coupling will only compensate for small amount of misalignment and should not be used to compensate for excessive misalignment of the pump and driver shafts.**

**Inaccurate alignment results in vibration and excessive wear on the bearings, sleeve or shaft and wear rings.**

Coupling alignment can be checked with dial gauge Indicator also. Alignment should be performed after the base plate has been properly set and grout has dried



thoroughly according to instructions. Final alignment should be made by shimming driver only.

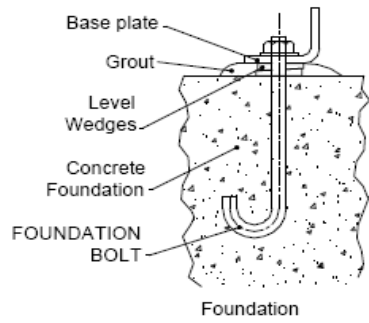
Alignment should be made at operating temperatures.

After final alignment, it is necessary to dowel pump and driver feet to the baseplate.

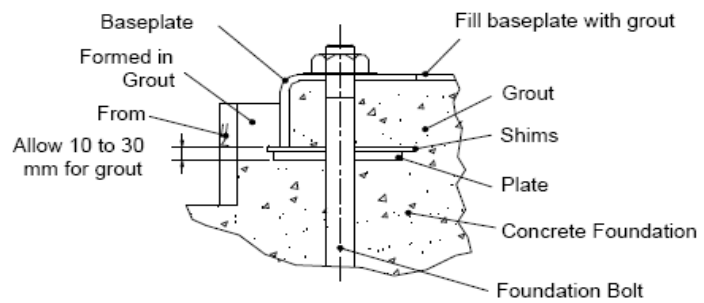
## **FACTORS THAT MAY DISTURB ALIGNMENT**

The unit should be periodically checked for alignment. If the unit does not stay in line after being properly installed, the following are possible reasons:

- a) Setting, Seasoning of the foundation.
- b) Pipe strains, distorting or shifting of the machines.
- c) Wear of the bearings.

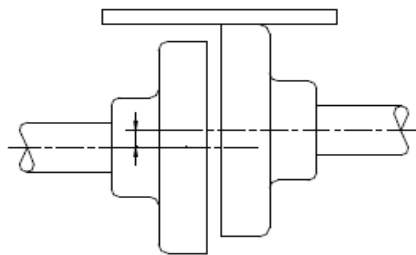


**FIG. 1**



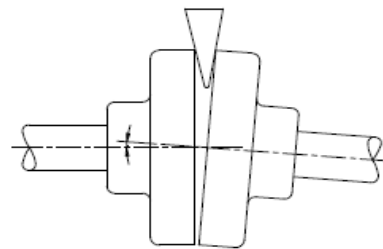
Setting Baseplate & Grouting

**FIG. 2**



Parallel Alignment

**FIG. 4**



Angular Alignment

**FIG. 3**

**COUPLING ALIGNMENT**



### 3.8 Suction and Discharge Piping

When installing the pump piping, make sure to observe the following precautions:-  
Piping should always run to the pump. Do not move pump to pipe. This could make final alignment impossible.

**Both suction and discharge piping should be supported independently and close to pump so that no strain is transmitted to the pump when the flange bolts are tightened.**

**Use pipe hangers or other supports at necessary intervals to provide support. When expansion joints are used in the piping system, they must be installed beyond the piping supports close to the pump.**

It is advisable to increase the size of both suction and discharge pipes at the pump connection to decrease the loss of head from friction.

Install piping as straight as possible, avoiding unnecessary bends. Where necessary, use 45 degree or long sweep 90 degree fitting to decrease friction losses.

**Make sure that all piping joints are air tight. Provide pipe expansions bellows when hot fluids are to be pumped. Where reducers are used, eccentric reducers are to be fitted in suction lines and straight taper reducers in discharge and vertical lines (See Fig.5).**

**Misuse of reducers may cause the formation of air pockets in the pipe and thus preventing the correct operation of the pump.**

**The suction pipe should be as short & direct as possible. Where suction lift is not very high, it is advisable to use a foot valve. Horizontal suction line must have a gradual rise to the pump.**

The discharge pipe is usually preceded by a non-return valve or check valve and a discharge gate valve (See Fig. 5). The check valve is to protect the pump from excessive back pressure and reverse rotation of the unit and to prevent back flow into the pump in case of stoppage or failure of the driver. The discharge valve is used in priming, starting and when shutting down the pump.



## 4 OPERATION

### 4.1 Before Starting

Before initial starting of the pump, make the following inspection:

- 4.1.1 The unit base plate is grouted and bolted to the foundation.
- 4.1.2 Alignment between pump and motor.
- 4.1.3 Motor is correctly wired to starting device, check voltage, phase and frequency on motor nameplate with line circuit. Ensure correct direction of rotation prior to coupling to pump. Check by starting motor and switching off immediately. Observe rotation is the same as the arrow direction on the pump casing.
- 4.1.4 Bearing lubrication is provided (see lubrication section), also check driver lubrication.
- 4.1.5 Mechanical seal has been fitted or stuffing box has been packed.
- 4.1.6 All rotating parts are found to be free when turned by hand.
- 4.1.7 Pump is primed. Never run the unit dry. The liquid in the pump serves as a lubricant for close running fits within the pump and the pump may be damaged if operated dry. The pump may be primed by using an ejector, exhauster or vacuum pump. If a foot valve is used in the suction line, the pump may be primed by venting and filling the casing with liquid.

### 4.2 Starting

- 4.2.1 Close valve in discharge line.
  - 4.2.2 Open fully all valves in the suction line.
  - 4.2.3 Turn on seal water to the stuffing box where external pipe supplied.
  - 4.2.4 Prime the pump.
  - 4.2.5 Start the pump driver.
  - 4.2.6 When the pump is operating at full speed, open the discharge valve slowly.
- Do not operate pump for prolonged periods with closed discharge valve, so as to avoid overheating.

The pump should be shut down at once and the trouble corrected if the pump is running at its rated speed and found to have any of the following defects:



- a) No liquid delivered.
- b) Not enough liquid delivered.
- c) Not enough pressure.
- d) Loss of liquid after starting.
- e) Excess vibration.
- f) Motor runs hot.
- g) Pump bearing overheating.

#### 4.3 Running

While the pump is running, a periodic inspection should be made of:

- a) Stuffing box (soft packed pumps only). Ensure there is sufficient leakage to lubricate the packing.
- b) Bearings. Check the bearings for temperature, which should not exceed pumped liquid temperature or 80 Deg. C whichever is the lower.
- c) With mechanical seal fitted pumps, check that there is no leakage from the stuffing box.
- d) Suction **and** discharge gauge readings.

#### 4.4 Stopping

- a) Slowly close delivery valve and shut down driving unit in accordance with manufacturer's instructions.
- b) Shut off external sealing liquid supply, if supplied, to relieve stuffing box pressure.
- c) Successful operation of the pump depends on accurate alignment. It is recommended to re-check the alignment after preliminary run.

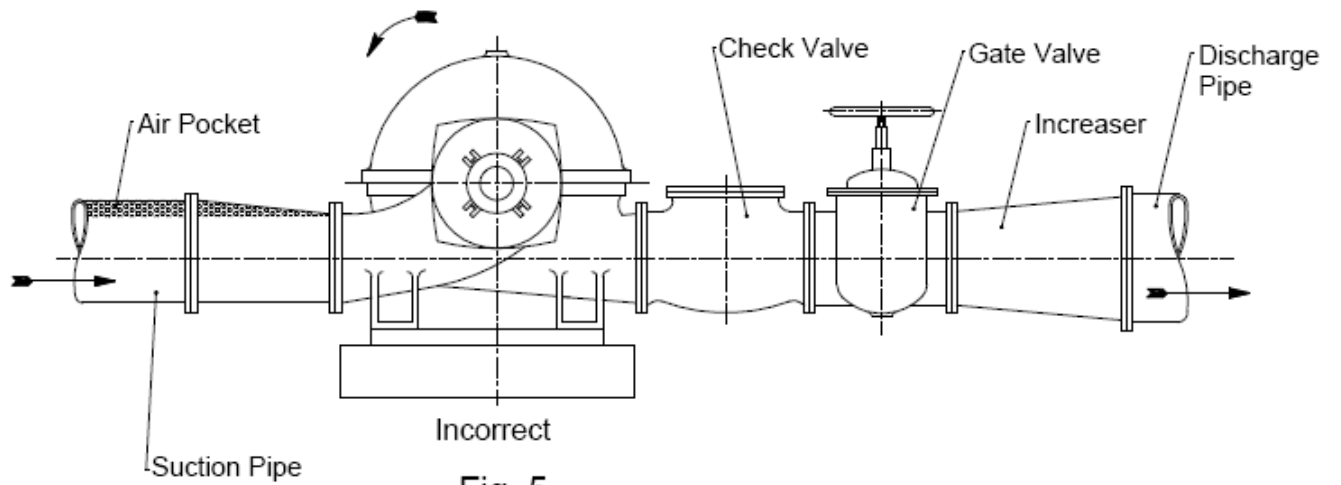
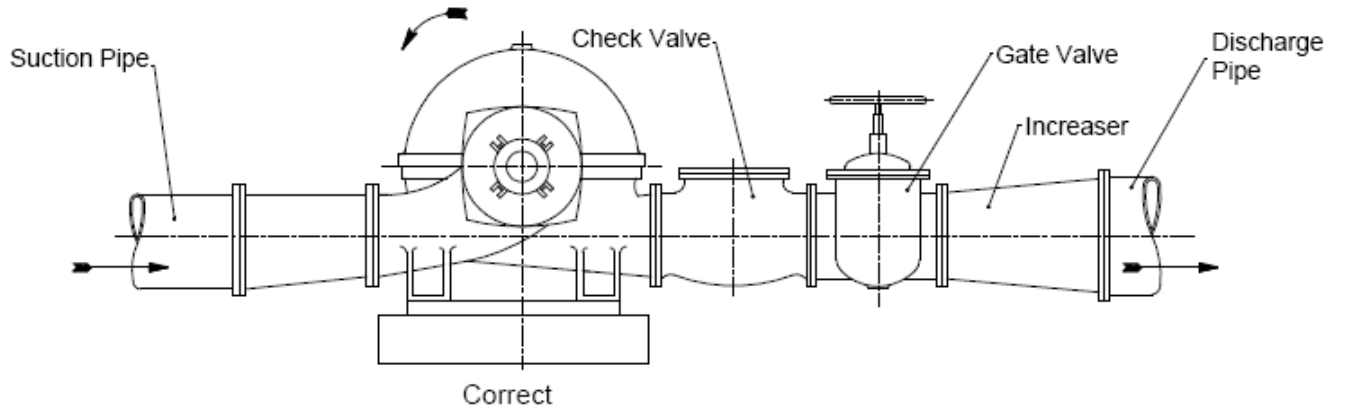


Fig. 5



## 5 TECHNICAL DATA

### 5.1 Direction of Rotation

The standard direction of rotation is Clockwise when viewed from driving side. The pumps with reverse direction of rotation (Anti-Clockwise) can be supplied on request.

The direction of rotation can be reversed easily without changing any part.

### 5.2 Bearing Details

The pumps are fitted with antifriction heavy duty ball bearings at driving and non driving ends. The details of the bearings are as under:

MODUL E	PUMP TYPE	BEARINGS		AMOUNT OF GREASE FOR EACH BEARING IN GMS
		DE	NDE	
I	SCT65/24 SCT80/24 SCT125/24 SCT150/24 SCT125/29 SCT80/30 SCT100/30 SCT125/30 SCT 50/38 SCT80/38	6306	6306	200
II	SCT100/24 SCT250/24 SCT150/30 SCT200/30 SCT250/30 SCT100/38 SCT125/38 SCT150/38 SCT250/40	6309	6309	200
III	SCT200/38 SCT250/38 SCT150/48 SCT200/48 SCT200/48C & CDV	6312	6312	200



The designations of bearings are as per SKF catalogue. However, bearings of other Make / equivalent are also used.

### 5.3 Special care for Bearings

These instructions do not supersede any information issued by the bearing manufacturers, to whom application should be made for more comprehensive literature by personnel responsible for bearing care, who with it to make a detailed study.

Care and maintenance of bearings is a matter of ensuring that they are:

- a) Correctly lubricated at intervals as laid down in routine maintenance chart.
- b) Removed, cleaned and refitted with care.
- c) Tools used and work areas should be cleaned.

To remove a bearing, use correctly suited withdrawal equipment.

**CAUTION:** Damage can be caused by exerting force against the outer ring of a ball bearing. Ball bearings should not be dismantled. Clean bearings thoroughly with an approved fluid. Dry the bearings by spinning with dry compressed air or by hand. Do not spin a clean dry bearing. Inspect the bearing for wear, fractures, cracks, corrosion or other damage which may necessitate bearing replacement. Pack both sides of bearing with grease. Check that the bearing, shaft and housing are cleaned and undamaged. Recharge with grease to a maximum of two thirds full. Refit the bearing onto the shaft and press for tap into position.

### 5.4 Lubrication Details

Initially bearings are lubricated during assembly. In the regreasing period these bearings should be repacked with a high quality, lithium soap base, ball and roller bearing grease free from resin and acid, not liable to harden or crumble and possessing rust preventive properties. Re-greasing interval depends upon the operating speed of the unit.



**Operating speed**

1450 RPM

2000 RPM

**Regressing Interval**

4000 hours

3000 hours

To recharge the bearings with fresh grease, use a grease gun and feed through the two grease nipples provided.

**DO NOT APPLY LUBRICANT WHEN PUMP IS RUNNING.**

After 10,000 hours or two years whichever is earlier remove bearings from pumps, degrease, thoroughly clean, recharge with fresh grease and refit in accordance with reassembly instructions.

**Recommended Grease specifications**

Manufacturer	Trade name
IOCL	SERVOGEM-3 OR EQ
IOCL	SERVOGEM-2 OR EQ
SHELL	ALVANIA EP 2
EXXON	POLYREX
CHEVRON	SRI GREASE NLGI 2
CHEVRON	BLACK PEARL NLGI 2
TEXACO	MULTIFAK EP2
PHILIPS	POLYTAC
HPCL	NATRA 3 OR LITHON 3

**5.5 Wearing Details**

Pumps are supplied with casing wear rings. The Diametrical clearances between Impeller and casing rings should be minimum: 0.25 mm and maximum 0.70 mm.

**5.6 Impeller Details**

Following pump types are fitted with single entry impeller SCT 50/38, SCT 80/38.

For other types, Double entry impellers are fitted.



## 5.7 Stuffing Box Details

- **Packing (Non Asbestos)**

On packed pumps the packing is installed prior to shipment. All packing used are the highest grade material. Before pump is put into operation check the condition of the packing. If pump is installed within sixty (60) days after shipment the packing will be in good condition with a sufficient supply of lubrication. If pump is stored for a longer period it may be necessary to repack the stuffing box. In all cases, however, we recommend an inspection of the packing before pump is started. The standard pump packing is made from graphite solid plate cotton packing (non asbestos).

A soft, well-lubricated packing reduces stuffing box resistance and prevents excessive wear on the shaft or shaft sleeve. Many brands of packing on the market have the desired qualities.

**NOTE:** Eccentricity of the shaft or sleeve through the packing could result in excess leakage that cannot be compensated for. Correction of this defect is very important. Packing should be checked frequently and replaced as service indicates. Six months might be a reasonable expected life, depending on operating conditions. It is impossible to give any exact predictions. A packing tool should be used to remove all old packing from the stuffing box. Never reuse old and lifeless packing or merely add some new rings. Make sure the stuffing box is thoroughly cleaned before new packing is installed. Also check the condition of the shaft or sleeve for possible scoring or eccentricity, make replacements where necessary.

New packing (non-asbestos) should be placed carefully into the stuffing box. If molded rings are used, the rings should be opened sideways and the joints pushed into the stuffing box first. The rings are installed one at a time, each ring seated firmly and the joints staggered at about a 90° rotation from each preceding joint.

Champion Style – 3116 – Graphite cotton greasy packing is used in the standard supply. However packing suitable for liquid handled is also supplied against specific requirement.

Size of gland packing and position of lantern ring





Gland packing are fitted with 2 + L + 2 arrangement L = Lantern Ring.

Module I - 10 mm<sup>2</sup>

Module II - 12 mm<sup>2</sup>

Module III - 12 mm<sup>2</sup>

### **Mechanical Seal:**

General instructions for operation of the various mechanical sealing arrangements are included below. It is not feasible to include detailed instructions for all mechanical seals in this booklet because of the almost unlimited number of possible combinations and arrangements. Instead, seal manufacturer's instructions will be included as a separate supplement to this book, where required.

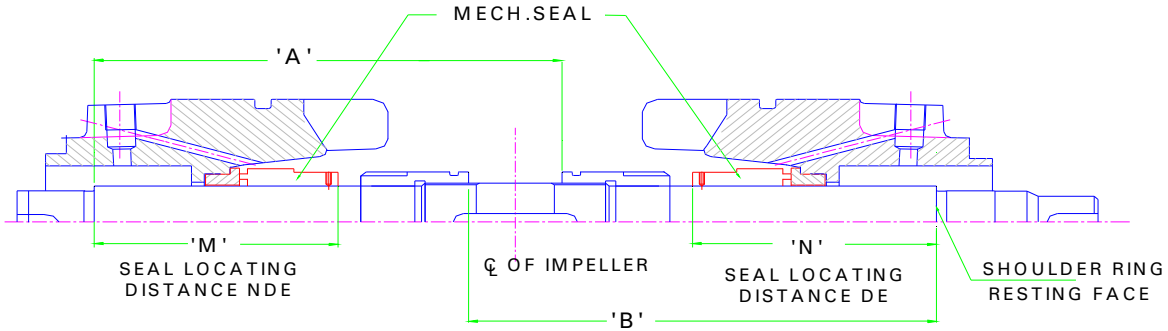
- a. Mechanical seals are precision products and should be treated with care. Use special care when handling seals. Clean oil and clean parts are essential to prevent scratching the finely lapped sealing faces. Even light scratches on these faces could result in leaky seals.
- b. Normally, mechanical seals require no adjustment or maintenance except routine replacement of worn or broken parts.
- c. A mechanical seal which has been used should not be put back into service until the sealing faces have been replaced or relapped. (Relapping is generally economical only in seals two inches in size and above.)

Four important rules which should always be followed for optimum seal life are:

1. Keep the seal faces as clean as possible.
2. Keep the seal as cool as possible.
3. Assure that the seal always has proper lubrication.
4. If seal is lubricated with filtered fluid, clean filter frequently.

# MECHANICAL SEAL FITTMENT CHART

## MECHANICAL SEAL DETAILS



FITMENT OF MECH. SEAL (AS PER DIN 24960 STANDARD) MOUNTED ON SHAFT					IMPELLER LOCKING DISTANCE	
PUMP TYPE	MODULE NO	SEAL SIZE	NDE M (mm)	DE N (mm)	'A' IN MM	'B' IN MM
65/24	1	35	99	103	198.5	202.5
80/24			99	103	198.5	202.5
125/24			108	112	252.5	256.5
150/24			108	112	252.5	256.5
125/29			99	103	198.5	202.5
80/30			99	103	198.5	202.5
100/30			99	103	198.5	202.5
125/30			108	112	252.5	256.5
80/38			99	103	198.5	202.5
50/38			99	103	198.5	202.5
100/24			II	50	112.5	116.5
150/30	112.5	116.5			256	260
200/30	127.5	131.5			316	320
250/24	127.5	131.5			316	320
250/30	127.5	131.5			316	320
100/38	112.5	116.5			256	260
125/38	112.5	116.5			256	260
150/38	112.5	116.5			256	260
250/40	IIA	50	112	116	316	320
200/38	III	65	109.5	113.5	330	334
250/38			109.5	113.5	330	334
150/48			109.5	113.5	330	334
200/48			109.5	113.5	330	334
200/48C & CDV			109.5	113.5	330	334



## 5.8 Coupling Details

Pumps will be supplied with snap wrap coupling as a standard scope of supply however other types like pin bush, tyre type, spacer coupling can also be provide on request.

## 5.9 Minimum safe flow

The pump should not run against closed discharge valve as this will cause an increase in temperature/formation of steam in the pump. This may cause shaft damage, impeller erosion, short life of bearings and damage to stuffing boxes or mechanical shaft seals due to stress or vibration. The minimum flow rate must be at least 30 % of the best efficiency point flow rate.

## 5.10 NPSHA (Net Positive Suction Head Available) and NPSHR (Net Positive Suction Head Required)

NPSHA should be at least greater than 0.5m than NPSHR for satisfactory operation of the pump. If  $NPSHA < NPSHR$  then pump cavitation may occurs which in turns damage the impeller.

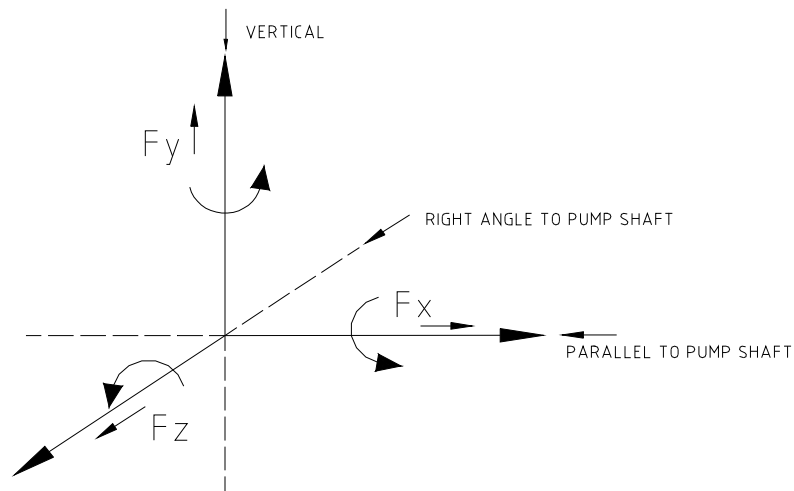
## 5.11 Pipe line velocities

For satisfactory operation of pumps and to minimize frictional losses, it is recommended to maintain velocity in suction pipe line as 1.5 to 2 m/s and in delivery pipe line it should be 2.5 to 3 m/s by providing higher pipe diameters than pump suction / delivery size.

## 5.12 Tapping details:

Sr.No	Tapping Description	Size (in inch)
1	Air vent	Rp 1/4
2	Priming connection (plugged)	Rp 1/2
3	Sealing connection	Rp 1/4
4	Suction & delivery pressure gauge connection (plugged)	Rp 1/4
5	Casing drain	Rp 1/2

### 5.13 Allowable forces and moments on pump flanges:



NOZZLE SIZE(mm)	Forces kg			Moment kg m		
	F <sub>x</sub>	F <sub>y</sub>	F <sub>z</sub>	M <sub>x</sub>	M <sub>y</sub>	M <sub>z</sub>
50	44	111	267	204	102	102
65	57	144	356	272	136	136
80	71	178	420	320	160	160
100	89	222	453	345	172	172
125	111	278	483	368	184	184
150	133	334	513	391	195	195
200	178	445	540	420	215	215
250	210	525	573	437	218	218
300	226	566	634	483	241	241

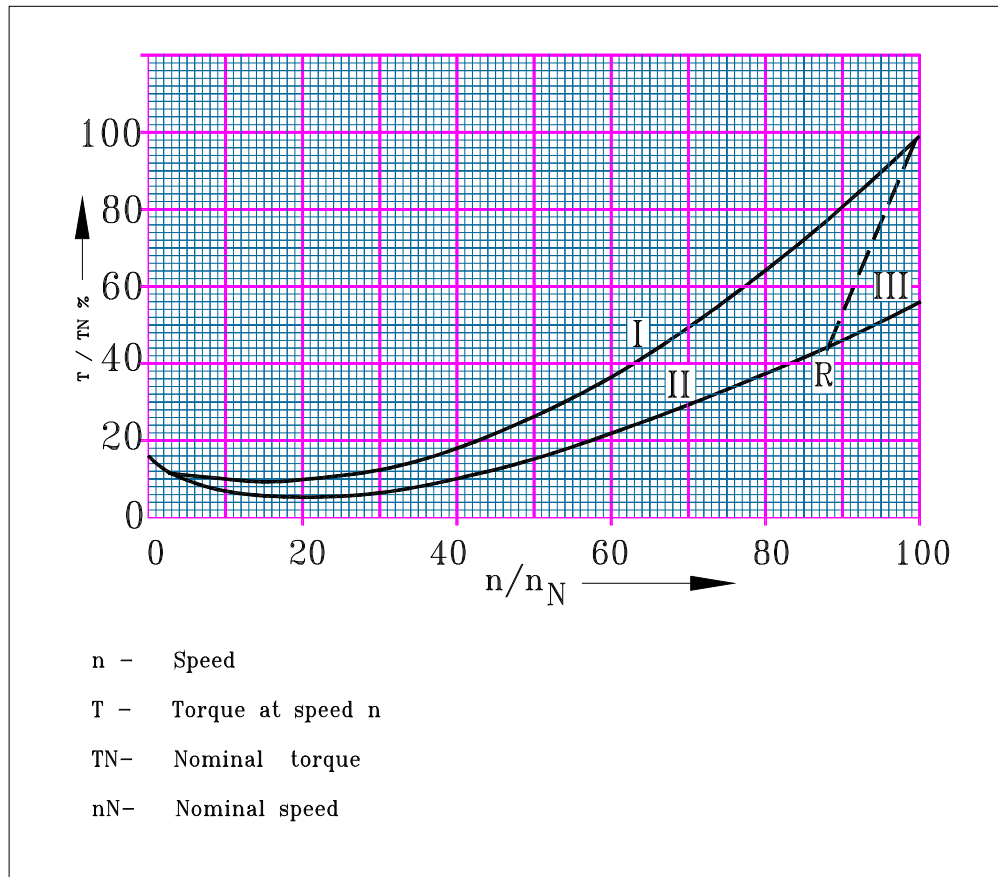
**5.14 Suction & Delivery Size:**

<b>PUMP YPE</b>	<b>NOMINAL SUCTION BORE mm</b>	<b>NOMINAL DELIVERY BORE mm</b>
SCT65/24	80	65
SCT80/24	100	80
SCT100/24	150	100
SCT125/24	150	125
SCT150/24	200	150
SCT125/29	150	125
SCT80/30	100	80
SCT100/30	125	100
SCT125/30	150	125
SCT80/38	100	80
SCT50/38	80	50
SCT150/30	200	150
SCT200/30	250	200
SCT250/24	250	250
SCT250/30	250	250
SCT100/38	125	100
SCT125/38	150	125
SCT150/38	200	150
SCT250/40	300	250
SCT200/38	250	200
SCT250/38	300	250
SCT150/48	200	150
SCT200/48	250	200
SCT200/48C & CDV	250	200

**5.15 Maximum allowable Speed and water fill capacity**

<b>PUMP YPE</b>	<b>WATER FILL CAPACITY (Lit)</b>	<b>NOMINAL SPEED (rpm)</b>	<b>MAXIMUM ALLOWABLE SPEED (rpm)</b>
SCT65/24	10	1450	3550
SCT80/24	14	1450	3550
SCT100/24	20	1450	3550
SCT125/24	30	1450	2520
SCT150/24	35	1450	1860
SCT125/29	18	1450	2260
SCT80/30	14	1450	3040
SCT100/30	20	1450	2450
SCT125/30	30	1450	1760
SCT80/38	16	1450	1930
SCT50/38	14	1450	2120
SCT150/30	40	1450	2720
SCT200/30	60	1450	2460
SCT250/24	63	1450	2800
SCT250/30	65	1450	2100
SCT100/38	25	1450	2780
SCT125/38	35	1450	2660
SCT150/38	45	1450	2080
SCT250/40	100	1450	1500
SCT200/38	70	1450	2640
SCT250/38	100	1450	2080
SCT150/48	68	1450	2100
SCT200/48	85	1450	1760
SCT200/48C & CDV	85	1450	2100

### 5.16 Starting Torque:



CASE 1 starting up with open isolating or regulating valve on delivery side.

CASE 2 starting up with closed isolating or regulating valve with opening the valve when nominal speed is attained.

CASE 3 starting up with open isolating or regulating valve but against static delivery head acting on non-return valve.

**5.17 Weights and GD<sup>2</sup> values:**

PUMP TYPE	WEIGHT (Kg)	GD <sup>2</sup> (Kg-m <sup>2</sup> )
SCT65/24	130	0.2128
SCT80/24	142	0.222
SCT100/24	210	0.3928
SCT125/24	254	0.3688
SCT150/24	290	0.3088
SCT125/29	196	0.454
SCT80/30	159	0.2888
SCT100/30	189	0.516
SCT125/30	249	0.5768
SCT80/38	196	1.102
SCT50/38	196	1.0368
SCT150/30	336	0.8728
SCT200/30	511	1.1308
SCT250/24	450	0.6528
SCT250/30	492	1.012
SCT100/38	280	0.8908
SCT125/38	354	1.3208
SCT150/38	377	1.2728
SCT250/40	750	3.750
SCT200/38	574	1.9608
SCT250/38	747	3.136
SCT150/48	647	4.916
SCT200/48	618	4.656
SCT200/48C	620	4.656
SCT200/48CDV	650	4.7



**5.18 INTERCHANGEABILITY of Components**

PART CODE	NAME OF THE PART	TOTAL No. OF PARTS	65/24	80/24	125/24	150/24	125/29	80/30	100/30	125/30	50/38	80/38	100/24	250/24
1220001	UPPER HALF CASING	22	1	2	3	4	5	6	7	8	9	10	11	12
1230001	LOWER HALF CASING	22	1	2	3	4	5	6	7	8	9	10	11	12
1590001	IMPELLER	24	1	2	3	4	5	6	7	8	9	10	11	12
1800101	PUMP SHAFT	5	1	1	2	2	1	1	1	2	1	1	3	4
1900001	WEAR RING	10	1	1	5	5	2	1	2	5	3	3	4	7
1990001	SHOULDER RING	3	1	1	1	1	1	1	1	1	1	1	2	2
2230001	GLAND	3	1	1	1	1	1	1	1	1	1	1	2	2
2270001	LANTERN RING	3	1	1	1	1	1	1	1	1	1	1	2	2
2360001	DEFLECTOR	3	1	1	1	1	1	1	1	1	1	1	2	2
2400101	BEARING HOUSING DE	3	1	1	1	1	1	1	1	1	1	1	2	2
2400201	BEARING HOUSING NDE	3	1	1	1	1	1	1	1	1	1	1	2	2
2600001	BALL BEARING DE & NDE	3	1	1	1	1	1	1	1	1	1	1	2	2
2700001	BEARING COVER DE & NDE	3	1	1	1	1	1	1	1	1	1	1	2	2
3100001	SHAFT SLEEVE DE & NDE	3	1	1	1	1	1	1	1	1	1	1	2	2
3200001	IMPELLER KEY	3	1	1	1	1	1	1	1	1	1	1	2	2
3210001	COUPLING KEY	3	1	1	1	1	1	1	1	1	1	1	2	2
3360001	BEARING LOCK NUT	3	1	1	1	1	1	1	1	1	1	1	2	2
5000001	OIL SEAL	3	1	1	1	1	1	1	1	1	1	1	2	2
5220101	"O"RING INSERT	5	1	1	3	3	2	1	2	3	2	2	2	4
5220201	"O"RING SHAFT SLEEVE	3	1	1	1	1	1	1	1	1	1	1	2	2
9790001	INSERT DE & NDE	8	1	1	3	3	2	1	2	3	2	2	4	6



PART CODE	NAME OF THE PART	150/30	200/30	250/30	100/38	125/38	150/38	200/38	250/38	150/48	200/48	200/48C	250/40
1220001	UPPER HALF CASING	13	14	15	16	17	18	19	20	21	22	22	20
1230001	LOWER HALF CASING	13	14	15	16	17	18	19	20	21	22	22	20
1590001	IMPELLER	13	14	15	16	17	18	19	20	21	22	23	24
1800101	PUMP SHAFT	3	4	4	3	3	3	5	5	5	5	5	4
1900001	WEAR RING	6	7	7	4	6	6	8	8	9	8	8	10
1990001	SHOULDER RING	2	2	2	2	2	2	3	3	3	3	3	2
2230001	GLAND	2	2	2	2	2	2	3	3	3	3	3	2
2270001	LANTERN RING	2	2	2	2	2	2	3	3	3	3	3	2
2360001	DEFLECTOR	2	2	2	2	2	2	3	3	3	3	3	2
2400101	BEARING HOUSING DE	2	2	2	2	2	2	3	3	3	3	3	2
2400201	BEARING HOUSING NDE	2	2	2	2	2	2	3	3	3	3	3	2
2600001	BALL BEARING DE & NDE	2	2	2	2	2	2	3	3	3	3	3	2
2700001	BEARING COVER DE & NDE	2	2	2	2	2	2	3	3	3	3	3	2
3100001	SHAFT SLEEVE DE & NDE	2	2	2	2	2	2	3	3	3	3	3	2
3200001	IMPELLER KEY	2	2	2	2	2	2	3	3	3	3	3	2
3210001	COUPLING KEY	2	2	2	2	2	2	3	3	3	3	3	2
3360001	BEARING LOCK NUT	2	2	2	2	2	2	3	3	3	3	3	2
5000001	OIL SEAL	2	2	2	2	2	2	3	3	3	3	3	2
5220101	"O"RING INSERT	3	4	4	2	3	3	5	5	5	5	5	4
5220201	"O"RING SHAFT SLEEVE	2	2	2	2	2	2	3	3	3	3	3	2
9790001	INSERT DE	5	6	6	4	5	5	7	7	7	7	7	8

## 6. INTENANCE.

### 6.1 Maintenance EHS (Environmental Hazard Safety) Instructions

Following hazards may arise during maintenance work.



#### **Fluid Pressure Jet Hazards**

Check and ensure that the pump operates at below the maximum Working Pressure specified.



#### **Hazardous materials:**

Wear a suitable mask or respirator when working with chemical material handling.



#### **Hazardous Gases, Mists, Sprays and Leaks.**

Be aware of the hazards relating to the pumped fluid, especially the danger from inhalation from noxious and toxic gases, skin and eye contact or penetration. Obtain and understand the hazardous substance data sheets relating to the pumped fluid and note the recommended emergency and first aid procedures.

Before attempting any maintenance on a pump, particularly if it has been handling any form of hazardous liquid; ensure that the unit is safe to work on. The pump must be flushed thoroughly with suitable cleanser to purge away any of the product left in the pump components. The plant operator should carry this out and a certificate of cleanliness obtained before starting work. To avoid any risk to health it is also advisable to wear protective clothing as recommended by the site safety officer, especially when removing old packing that may be contaminated.



**Electric shock and accidental starting hazard:**

Isolate the equipment before any maintenance work is done. Switch off the mains supply, remove fuses, apply lockouts where applicable and affix suitable isolation warning signs to prevent inadvertent re-connection.

In order to avoid the possibility of maintenance personnel inhaling dangerous fumes or vapours, it is recommended that maintenance work be carried out away from the pump location by removal of the rotating unit assembly to a suitable maintenance area.

**6.1 Routine Maintenance Chart**

Preventive maintenance schedule is a periodical checks and precautions by which possibilities of failure and breakdown will be rare.

<b>EVERY WEEK</b>	Visually check for leaks Check for vibration. Adjust gland as necessary to maintain slight leakage. Hand test bearing housing for any sign of temperature. Voltage and current.
<b>EVERY MONTH</b>	Check bearing temperature with thermometer.
<b>EVERY MONTHS</b> <b>3</b>	Check grease lubricated bearings for saponification.
<b>EVERY MONTHS</b> <b>6</b>	Check the packing and replace if necessary. Check shaft or shaft sleeve for scoring. Check alignment of pump and motor. Check holding down bolts for tightness. Check coupling bush/rubber star.
<b>EVERY YEAR</b>	Check rotating element for wear. Check wear ring clearances. Clean and regrease bearings. Measure total suction and discharge Head as a test of pipe connection



## 7.0 OVERHAULING

With normal daily operating spell, the pump will be due for overhaul after about 5000 working hours. This work should be done by skilled personnel. Please refer to the cross sectional drawing while dismantling and reassembling the pump. Please also refer to chart given at end of this booklet.

### 7.1 Dismantling Procedure

Note – Store all loose components carefully in a wooden box. Remove sealing connection given to lantern ring / mechanical seal, temperature indicator, etc.

#### 7.1.1 For **SOFT PACKED SCT PUMPS: (MODULE I,II & III)**

7.1.1.1 Disengage pump coupling from motor coupling.

Drain the pump by removing drain plug (60100) and opening air vent valve (45000).

7.1.1.2 Remove the nuts (58001) and locating pin (61100) joining the upper half casing and lower half casing.

7.1.1.3 Insert a screw driver or peg bar into the slot between the two halves and separate two halves, lifting off the upper half casing (12200). Remove the upper half casing, taking enough care not to damage the impeller and casing (wear) ring.

7.1.1.4 Tap the inserts (97900) with a soft hammer to break the seat between the insert and lower half casing (12300) and lift the rotating unit out of the lower half casing so that none of the parts will be damaged. Take out the rotating unit & keep it on rubber or wooden sheet in clean & dry place for further dismantling purpose.

7.1.1.5 Remove the pump coupling and coupling key.

7.1.1.6 Remove four hex screws (57100) from each bearing housing (24001 and 24002) and remove the bearing housing from bearings & take it off the shaft.

7.1.1.7 Remove bearing lock nut (33600) and lock washer (41500) from NDE side.

7.1.1.8 Remove NDE bearing (26000) from the shaft by the use of bearing puller. Remove driving end bearing in the same manner.

7.1.1.9 Remove oil seals (50000) from the insert from DE & NDE side. Remove shoulder rings (19900) from the shaft by using puller.

7.1.1.10 Remove stuffing box cover (22000) from insert by removing hex screw (57101).



**(This step is applicable for Module I & II only)**

- 7.1.1.11 Remove gland nuts (58200) from each gland. Slide back gland (22300) on the shaft & take out gland packings (43000) & lantern rings (22700) from each insert.
- 7.1.1.12 Slide inserts (97901, 97902) off the shaft along with gland & stuffing box packing ring (20700).
- 7.1.1.13 Take out casing rings (19000) on DE & NDE side.
- 7.1.1.14 **For counter clockwise (CCW) direction of rotation of pump viewed from driving end, follow steps (i & ii) and then go to point no. 7.1.1.16:**
- i) Unscrew DE side shaft sleeve and slide it off the shaft from DE side. Remove impeller from shaft. Remove impeller key.
  - ii) Unscrew the NDE side shaft sleeve and slide it off the shaft from NDE side.
- 7.1.1.15 **For clockwise (CW) direction of rotation of pump viewed from driving end, follow steps (i & ii) then go to point no. 7.1.1.16:**
- i) Unscrew NDE side shaft sleeve and slide it off the shaft from NDE side. Remove impeller from shaft. Remove impeller key.
  - ii) Unscrew the DE side shaft sleeve and slide it off the shaft from DE side.
- 7.1.1.16 Store all parts of rotating assembly in clean and dry place and arrange to store the parts in well oiled condition.
- 7.1.1.17 Mechanical seal arrangement –**
- All SCT pumps are fitted with bare mechanical seal only.
- a) Dismantling procedure for mechanical seal fitted pump is same as above except step no. 7.1.1.10 & 7.1.1.11 After step no. 7.1.1.09, slide inserts (97901, 97902) off the shaft.
  - b) Remove grub screws holding mechanical seal & slide off mechanical seal from DE & NDE side.
  - c) Then follow steps 7.1.1.13 to 7.1.1.16.
- This completes the dismantling of the pump.



## 7.2 Reassembly Procedure -

### 7.2.1 For SCT pumps:

- 7.2.1.1 Check 'O' ring (52202) for cut or flaws, discard if faulty, lubricate and roll 'O' ring in groove of each shaft sleeve.
- 7.2.1.2 Wipe over shaft (18001) with clean light oil.
- 7.2.1.3 Keep shaft so that coupling end extension is in correct position looking from position of suction and delivery branches.
- 7.2.1.4 **For counter clockwise (CCW) direction of rotation of pump viewed from driving end, follow steps (i, ii & iii) and then go to point no.7.2.1.6:**
- i) Locate the locking shaft sleeve (31000) at NDE side with the help of impeller key (32000) and tighten it on the shaft. Please check that the "o" ring is fitted in groove of sleeve.
  - ii) **Check impeller vanes for correct direction of rotation.** Slide the impeller on the shaft. Check that keyway provided on shaft extends equally outside the hub of impeller on both sides.
  - iii) Slide DE side adjusting sleeve in the shaft and tight it against impeller hub with the help of set screw.
- 7.2.1.5 **For clockwise (CW) direction of rotation of pump viewed from driving end, follow steps (i, ii & iii) and then go to point no.7.2.1.6.**
- i) Locate the locking shaft sleeve (31000) at DE side with the help of impeller key and tighten it on the shaft. Please check that the "o" ring is fitted in groove of sleeve.
  - ii) **Check impeller vanes for correct direction of rotation.** Slide the impeller on the shaft. Check that keyway provided on shaft extends equally outside the hub of impeller on both sides.
  - iii) Slide the NDE side adjusting sleeve in the shaft and tight it against impeller hub with the help of set screw.
- 7.2.1.6 Apply a hand of light oil on casing rings (19000) and place casing rings on the impeller.

- 7.2.1.7 Check 'O' rings (52201) for cracks or flaws, discard if faulty. Lubricate and roll 'O' ring (52201) into the groove in each insert (97901, 97902).
- 7.2.1.8 Slide inserts (97901, 97902) over shaft with guide vane at top position.
- 7.2.1.9 Slide stuffing box packing ring (20700), Slide gland packings (43000) & lantern ring(22700) combination as per chart. Slide glands (22300) over the shaft & fix it to insert with stud & nut.
- 7.2.1.10 Slide stuffing box cover over shaft & fix it with insert by means of hex screw(57101).( **This step is applicable for Module I & II only.**)

#### 7.1.1.11 Mechanical seal arrangement –

- a) Assembly procedure for mechanical seal fitted pump is same as above except step no. 7.1.1.8, 7.1.1.9 & 7.1.1.10 After step no. 7.1.1.07, Slide bare mechanical seal over the shaft and locate the same on the shaft with the help of grub screws.
- b) Slide inserts (97901, 97902) off the shaft
- c) Then follow steps 7.1.1.12 to 7.1.1.29.
- 7.2.1.12 Fit shoulder ring (19900) onto shaft, then fit oil seal (50000) into insert. Ensure that no foreign particle should enter in bearing assembly. See sectional drawing.
- 7.2.1.13 Heat the ball bearing (26000) to approximately 100°C (212°F) using heating oil bath.

NOTE: DO NOT EXCEED 120°C (250°F).



- 7.2.1.14 Use hand gloves while handling heated bearings.

Slide the heated bearing on to the shaft to about shoulder ring (19900) at non driving end. Place locking washer (44500) onto shaft & screw bearing lock nut (31500) using hook spanner. Tight the lock nut against bearing. Bend the washer in the slot of bearing lock nut.

Cool the bearing to room temperature and coat both sides with grease.



- 7.2.1.15 Coat the inside of the bearing housing (24002) with grease and slide into place over bearing. Secure bearing housing to insert with four hex head screws (57100).
- 7.2.1.16 At coupling end heat the bearing (26000) to approximately 100°C (212°F) using heating oil bath.

NOTE: DO NOT EXCEED 120°C (250°F).

- 7.2.1.17 Slide the heated bearing onto the shaft to about shoulder ring (19900) at coupling end.



Use hand gloves while handling heated bearings.

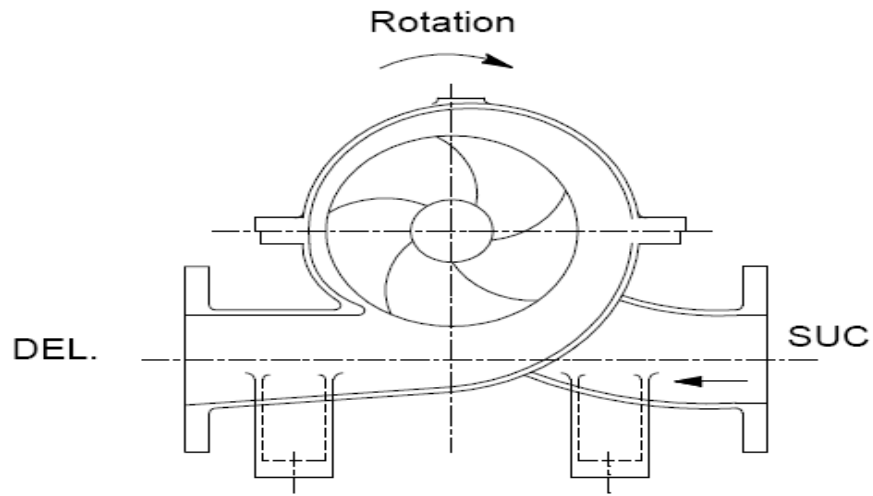
- 7.2.1.18 Cool the bearing to room temperature and coat both sides with grease.
- 7.2.1.19 Coat the inside of the bearing house (24002) with grease and slide into place over bearing. Secure bearing housing to insert with four hex screws (57100).
- 7.2.1.20 Fit locating pins (61000) for casing ring (DE & NDE) and insert (DE & NDE) in their respective holes in lower half casing.**
- 7.2.1.21 Lift the rotating unit by means of crane. Set the rotating unit in the lower casing half. Locate both insert tongues at top position. Correct any excessive 'O' ring buckling. Check whether Impeller is centrally placed in volute and there is no rubbing between impeller and casing.
- 7.2.1.22 Ensure that casing rings are located in cylindrical pins fitted in lower half casing. Install gasket (51900) between upper & lower half casing with a light coat of grease on both gasket surfaces.  
Carefully align the inner edge of gasket with the insert 'O' rings.
- 7.2.1.23 Lift upper half casing (12200) and place it on lower half casing and engage casing joint nuts loosely.  
NOTE: When installing upper half casing make sure that the 'O' rings (52201) are not cut or punched.



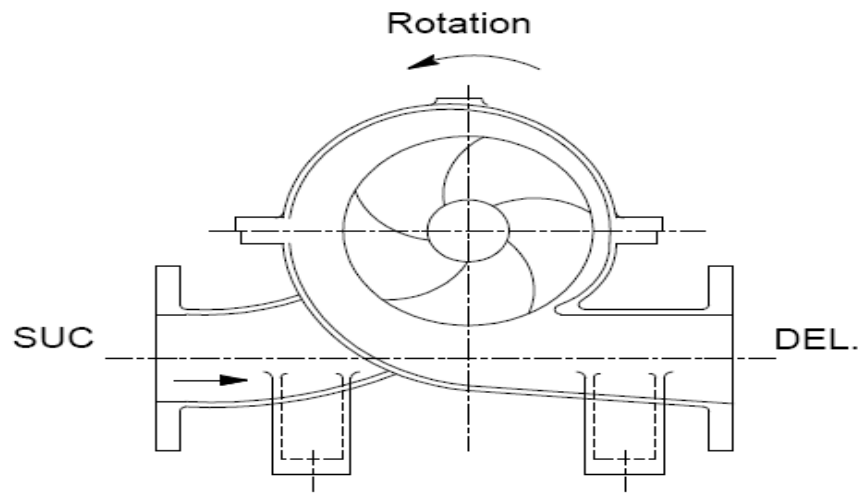
- 7.2.1.24 Insert locating pins (61100) for upper & lower half casing and drive them home. Tighten upper half casing to lower half casing by studs and nuts.
- 7.2.1.25 Fill the gland packing along with lantern ring in the correct sequence as given in technical data. Then fit gland to the insert with studs & hex nut. (This step is not applicable for mechanical seal fitted pump.)
- 7.2.1.26 Mount all the accessories such as grease nipple, sealing / flushing connection etc.
- 7.2.1.27 Rotate the shaft by hand to assure smooth rotation and that it is free from rubbing or binding.
- 7.2.1.28 Mount the pump coupling key and fit the pump coupling on the shaft from DE side.
- 7.2.1.29 Align motor coupling with pump coupling within 0.05 mm to each other.



Enriching Lives



CLOCKWISE ROTATION VIEWED FROM THE COUPLING END



COUNTER CLOCKWISE ROTATION VIEWED FROM THE COUPLING END

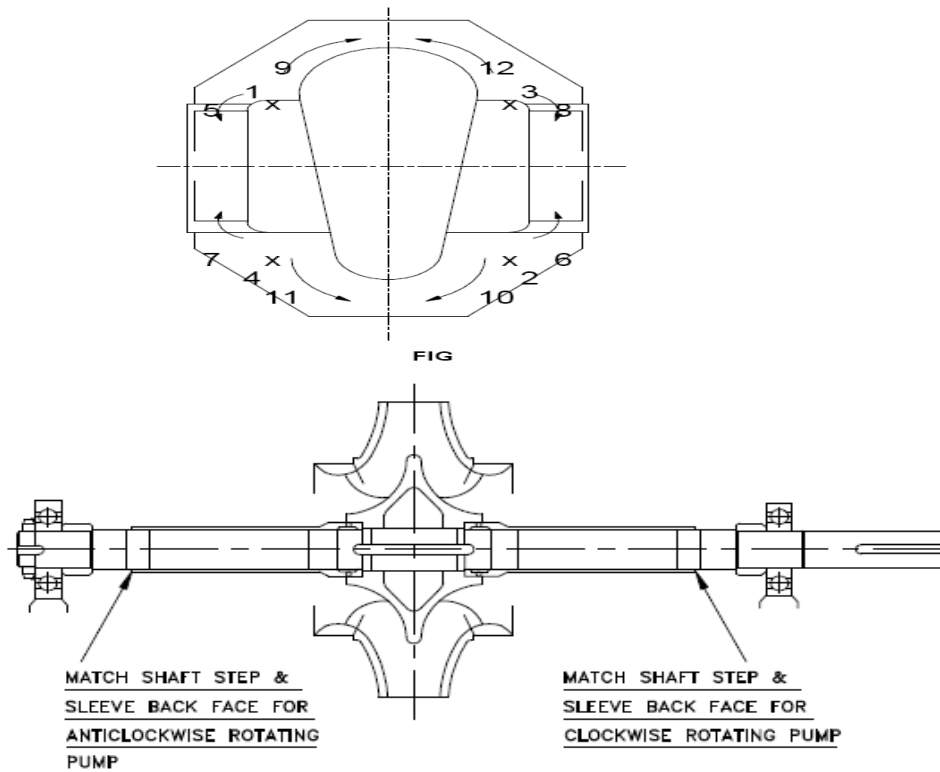
## JOINT FLANGE

## TIGHTENING TORQUES AND SEQUENCE

Stud and Nut use in this main joint flange of UP pumps should be tightened to the torques stated in table 1 and in the sequence stated in Fig.

STUD SIZE	TIGHTENING TORQUES
M12	250Kg-CM
M16	650Kg-CM
M20	1270Kg-CM
M24	2200Kg-CM

2. Tightening sequence.
  - 2.1 Tighten the four corner stud marked 'X' 1, 2, 3, and 4
  - 2.2 Work outward along shaft axis towards the stuffing boxes in opposite quarters tightening nut in regions 5, 6, 7 and 8.
  - 2.3 Work outwards along the branch and in opposite quarters tightening nuts in regions 9, 10, 11, and 12.
  - 2.4 Repeat the whole sequence.



Sleeve Location

## INSTALLING STUFFING BOX PACKING



1. Refer to stuffing box data to ascertain size and number of rings required.
2. If the packing is to be cut from a coil or long length:-
  - a) Wrap the packing around a dummy shaft, equal to the shaft sleeve diameter.
  - b) To assist in cutting rings, two guide lines parallel to the shaft axis and separated by a distance equal to the packing section may be drawn on the spiral.
  - c) **Cut the rings from the spiral at an angle of 45° diagonally across the guide lines no gap is left between the ends.**
3. Insert the first ring and tap it to the bottom of the stuffing box. Each following ring should be installed in the same manner and positioned in the stuffing box so that the split is advanced 90 Deg.  

Install the lantern ring in its proper position to align with the sealing connection allowing for movement of the ring deeper in to the box as the packing is compressed.
4. When the correct number of rings have been inserted, the last packing ring should not protrude past the stuffing box face, so that the gland may be properly seated in the stuffing box bore.
5. **Bring the gland follower up securely against the last packing ring and tighten the nuts evenly to give pressure.**
6. Turn the shaft to ensure it does not bind on the bore or the gland follower.
7. Pressurize the stuffing box, ensuring air is not trapped. A packed gland must leak and leakage should take place commencing soon after the stuffing box is pressurized.
8. Until steady leakage takes place, the pump may overheat. If this happens, the pump must be stopped and allow to cool and, when restarted, leakage should take place. If it does not, this operation should be repeated. Gland nuts should not be slackened.
  9. After the pump has been running for 10 minutes with steady leakage, tighten the gland nuts by one sixth of a full turn. Continue to adjust at ten minute intervals, each time evenly by one sixth of a full turn, until leakage is reduced to an acceptable level. There should be leakage of 60 to 80 drops per minute.



**CAUTION:**

Excessive gland pressure will cause damage by cutting off lubrication to the packing and packing will burn and damage the sleeve.

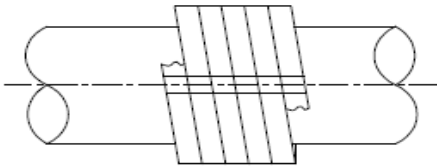


Fig. A

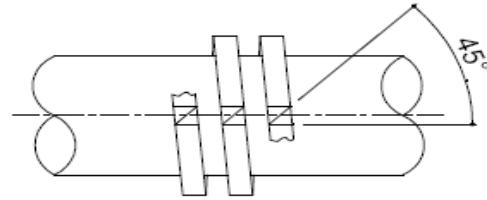
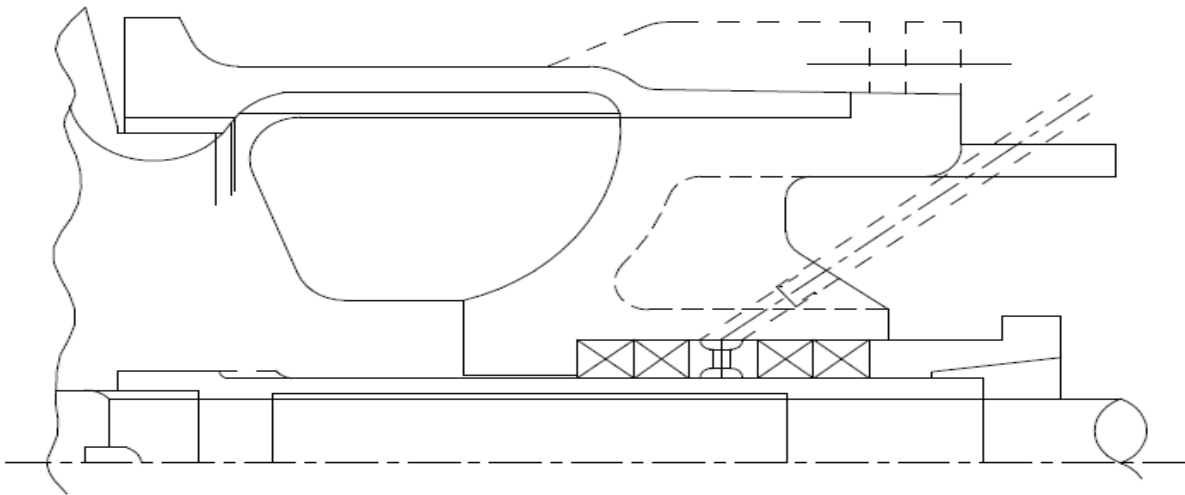
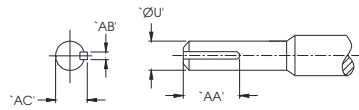
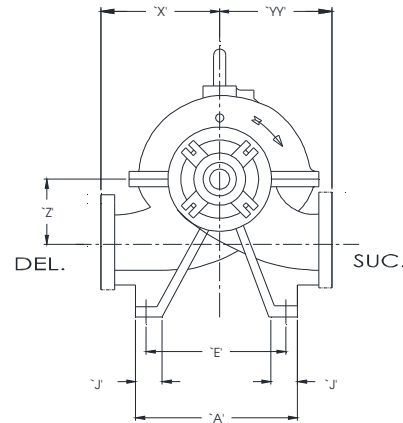
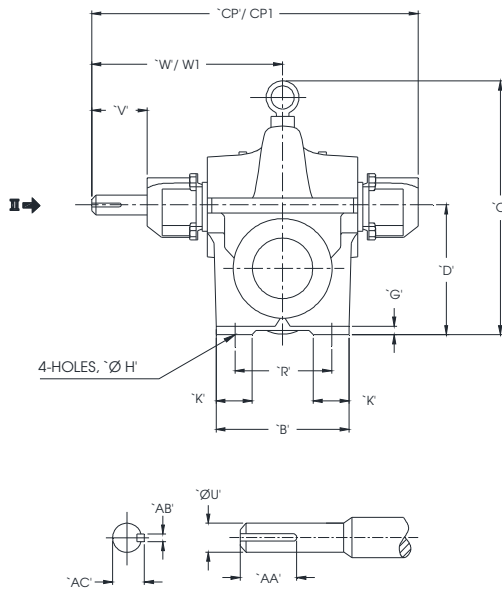


Fig. A





### 8.0 GENERAL OUTLINE DIMENSIONS:



MODUL NO.	Ø'U'	'AA'	'AB'	'AC'
1	25 <sub>js</sub>	63.5	8	28
2	42 <sub>ks</sub>	89.0	12	45
3	55 <sub>ms</sub>	102.0	16	59

PUMP TYPE	MODUL NO.	FOR SOFT PACKED														FOR MECH. SEAL							
		SUC.	DEL.	'A'	'B'	'D'	'E'	'G'	'H' Ø	'J'	'K'	'O'	'R'	'V'	'W'	'X'	'Z'	'CP'	'YY'	Wt IN Kg	W1	'CP'1	Wt IN Kg
SCT 50-38	1	80	50	400	330	300	340	25	22	65	65	642	270	71	398.5	280	170	730	355	196	313.5	560	181
SCT 65-24		80	65	350	300	250	290	25	22	65	65	495	240	71	398.5	225	130	730	280	130	313.5	560	117
SCT 80-24		100	80	350	300	280	290	25	22	65	65	528	240	71	398.5	230	130	730	270	142	313.5	560	128
SCT 80-30		100	80	350	300	280	290	25	22	65	65	554	240	71	398.5	275	150	730	290	159	313.5	560	147
SCT 80-38		100	80	400	330	320	340	25	22	65	65	645	270	71	398.5	350	175	730	340	196	313.5	560	181
SCT 100-30		125	100	350	300	320	290	25	22	65	65	620	240	71	398.5	275	170	730	320	189	313.5	560	176
SCT 125-24		150	125	400	330	340	340	25	22	75	75	635	270	71	430	250	180	792	350	254	345	622	241
SCT 125-29		150	125	350	300	340	290	25	22	75	75	632	240	71	398.5	290	160	730	310	196	313.5	560	183
SCT 125-30		150	125	400	330	340	340	25	22	75	75	648	270	71	430	290	175	792	335	249	345	622	236
SCT 150-24		200	150	400	330	390	340	25	22	75	75	694	270	71	430	310	200	792	365	290	345	622	276
SCT 100-24	2	150	100	350	300	340	290	25	22	75	75	648	240	102	500	250	170	902	310	210	401	704	185
SCT 100-38		125	100	450	330	340	390	25	22	75	75	686	270	102	500	350	190	902	340	280	401	704	254
SCT 125-38		150	125	470	330	390	390	25	22	75	75	770	270	102	500	350	210	902	400	354	401	704	334
SCT 150-30		200	150	420	420	440	340	25	22	75	75	800	360	102	500	315	235	902	365	336	401	704	314
SCT 150-38		200	150	420	420	440	340	25	22	75	75	815	360	102	500	350	210	902	410	377	401	704	357
SCT 200-30		250	200	510	500	540	450	25	22	75	75	922	440	102	545	385	285	990	450	511	446	792	489
SCT 250-24		250	250	420	420	440	340	25	22	75	75	813	360	102	545	340	210	990	490	450	446	792	424
SCT 250-30		250	250	530	500	540	450	25	22	75	75	930	440	102	545	400	250	990	430	492	446	792	470
SCT 250-40		300	250	600	500	540	490	28	27	110	90	1010	430	127	545	420	265	990	590	747	446	792	720
SCT 150-48		3	200	150	600	460	540	490	28	27	110	90	990	390	127	585	450	270	1046	510	647	496	870
SCT 200-38	250		200	550	420	460	440	28	27	110	90	870	350	127	585	420	225	1046	480	574	496	870	543
SCT 200-48	250		200	600	500	540	490	28	27	110	90	985	430	127	585	450	270	1046	550	618	496	870	586
SCT 250-38	300		250	600	500	540	490	28	27	110	90	1010	430	127	585	420	265	1046	590	747	496	870	720

- NOTES:-  
 1) ALL DIMENSIONS ARE IN mm.  
 2) FLANGE DRILLING BS 4504 PN 16 (FF).  
 3) FOR MECHANICAL SEAL VERSION EXCEPT SPECIFIED ALL DIMENTIONS REMAIN SAME.  
 4) STANDARD DIRECTION OF ROTATION CLOCKWISE VIEWED FROM DRIVING END.

2	OUTLINE DIMENSIONS FOR SCT 250/40 ADDED.	KBB/05.04.08
1	FEET DIMENSION 'A' REVISED AS PER COMPONENT DRAWING, DIM 470 WAS 450, 420 WAS 400 & 530 WAS 510 AS SHOWN.	RSB/26.10.06
REV NO.	BRIEF DESCRIPTION OF REVISION	SIGN/DATE



**9.0 SPARE PART LIST AND CROSS SECTIONAL DRAWINGS****\* marked part code nos. are recommended spares.**

PART CODE NO	PART DESCRIPTION
1220001	UPPER HALF CASING STD. BSP
1230001	LOWER HALF CASING STD BSP
1590001*	IMPELLER
1800001*	SHAFT SOFT PACKED
1810001*	SHAFT MECH.SEAL
1900001*	WEAR RING
1980101	SPACER FOR BEARING
1980201	SPACER RING(OUTER)
1990001	SHOULDER RING
1990101	SHOULDER RING 10UPH8
2010001	SPACER WASHER
2070001	ST.BOX PACKING RING
2200001	ST.BOX COVER BSP
2230001	GLAND
2240001	GLAND PLATE
2270001*	LANTERN RING
2300001*	MECHANICAL SEAL
2340001	RETAINER RING
2360001*	WATER DEFLECTOR
2400101	BEARING HOUSING D.E.BSP
2400201	BEARING HOUSING NDE.BSP
2600001*	BEARING
2700001	BRG. COVER NDE
2710001	BRG. COVER DE
3030001	EYE BOLT
3100001*	SHAFT SLEEVE SOFT PACKED
3200001*	IMPELLER KEY
3200101*	IMPELLER KEY
3210001*	KEY FOR COUPLING
3300001*	IMPELLER NUT
3340001	SLEEVE LOCK NUT
3340101	SLEEVE LOCK NUT
3360001	LOCK NUT FOR BEARING
4150001*	LOCK WASHER FOR BEARING
4300001*	GLAND PACKING
4410001	GREASE NIPPLE BSP
4500001	VENT VALVE BSP
5000001*	OIL SEAL



5190001*	GASKET BET.UPPER & LOWER HALF CSG.
5220101*	O RING FOR INSERT
5220201*	O RING FOR SLEEVE
5220301*	O RING FOR INSERT/COVER
5220401*	O RING FOR SLEEVE
5300001	PIPE NIPPLE BSP
5340001	PIPE NIPPLE
5420001	ELBOW BSP
5500001	WHEEL COCK
5600001	TUBE FOR SEALING
5710001	HEX. SCREW FOR BEARING HOUSING
5770001	HEX.SCREW FOR BRG. HSG.
5800001	HEX NUT FOR CASING/BRGHSG
5800201	HEX. NUT INSRT & ST.BOX
5810001	HEX.NUT FOR CASING
5820001	HEX. NUT FOR GLAND
5830001	GRUB SCREW FOR LIQUID DEFLECTOR
5830002	HEX SCREW FOR BRG HSG/INSERT
5830003	GRUB SCREW FOR DEFLECTOR
5830004	GRUB SCREWS FOR INSERT
5830101	GRUB SCREW FOR INSERT
5830201	GRUB SCREW FOR IMPELLER
5860001	HEX NUTS FOR CASING
5860002	HEX NUTS FOR GLAND
5900101	STUD FOR UPPER & LOWER HALF
5900201	STUD FOR UPPER & LOWER HALF
5900301	STUD FOR INSERT & ST.BOX
5920001	STUD FOR GLAND
5920101	STUD FOR CASING/GLAND
5930001	HEX SCREW
6000001	PIPE PLUG FOR GAUGE.BSP
6010001	PIPE PLUG FOR DRAIN.BSP
6020001	PIPE PLUG FOR SEALING
6030001	COLLARED PLUG FOR SEALING
6050001	SEALING PLUG FOR INSERT.BSP
6060001	PIPE PLUG FOR VENT BSP
6100101	LOCKING PIN FOR WEAR RING
6100201	LOCKING PIN FOR INSERT
6100301	PIN FOR FLUSHING
6110001	LOCATING PIN
6300001	RELE. SCREW FOR CASING
6400001	RIVET NAMEPLATE DIREC



6400101	RIVET NAMEPLATE DUTY
6570001	HEX SOCKET GRUB SCRE
6630001	GRUB SCREW FOR DEFLECTOR
6700001	DUTY NAMEPLATE
6720001	NAME PLATE DIRECTION
6720101	NAME PLATE DUTY
6910001	HEX. NUT FOR LOCATINGPIN
7290001	PIPE PLUG BSP VERTICLIS.N
8490001	PUNCHED WASHER FOR HEX SCREW
8490101	PUNCHED WASHER FOR GLAND
8490201	PUNCHED WASHER FOR LOCATING PIN
9780001	LOCATING RING
9790001	INSERT SOFT PACK BSP
9790101	INSERT (DE) SOFT PACK BSP
9790201	INSERT (NDE) SOFT PACK BSP

### Soft packed pump components

1800001*	PUMP SHAFT (SOFT PACKED)
2230001	GLAND
2270001	LANTERN RING
2360001	DEFLECTOR
3100001*	SHAFT SLEEVE (SOFT PACKED)
4300001*	GLAND PACKING
5820001	NUT (GLAND)
5920001	STUD (GLAND)
9790101	INSERT DE(SOFT PACKED)
9790201	INSERT NDE(SOFT PACKED)

### Common for Mechanical Seal & Gland Pack

#### a) Internal Flushing Components

5600001	TUBE FLUSHING
---------	---------------

#### Soft Packed Components

#### Gauge and drain connection (If Ordered)

6000001	GAUGE PLUG
6010001	DRAIN PLUG

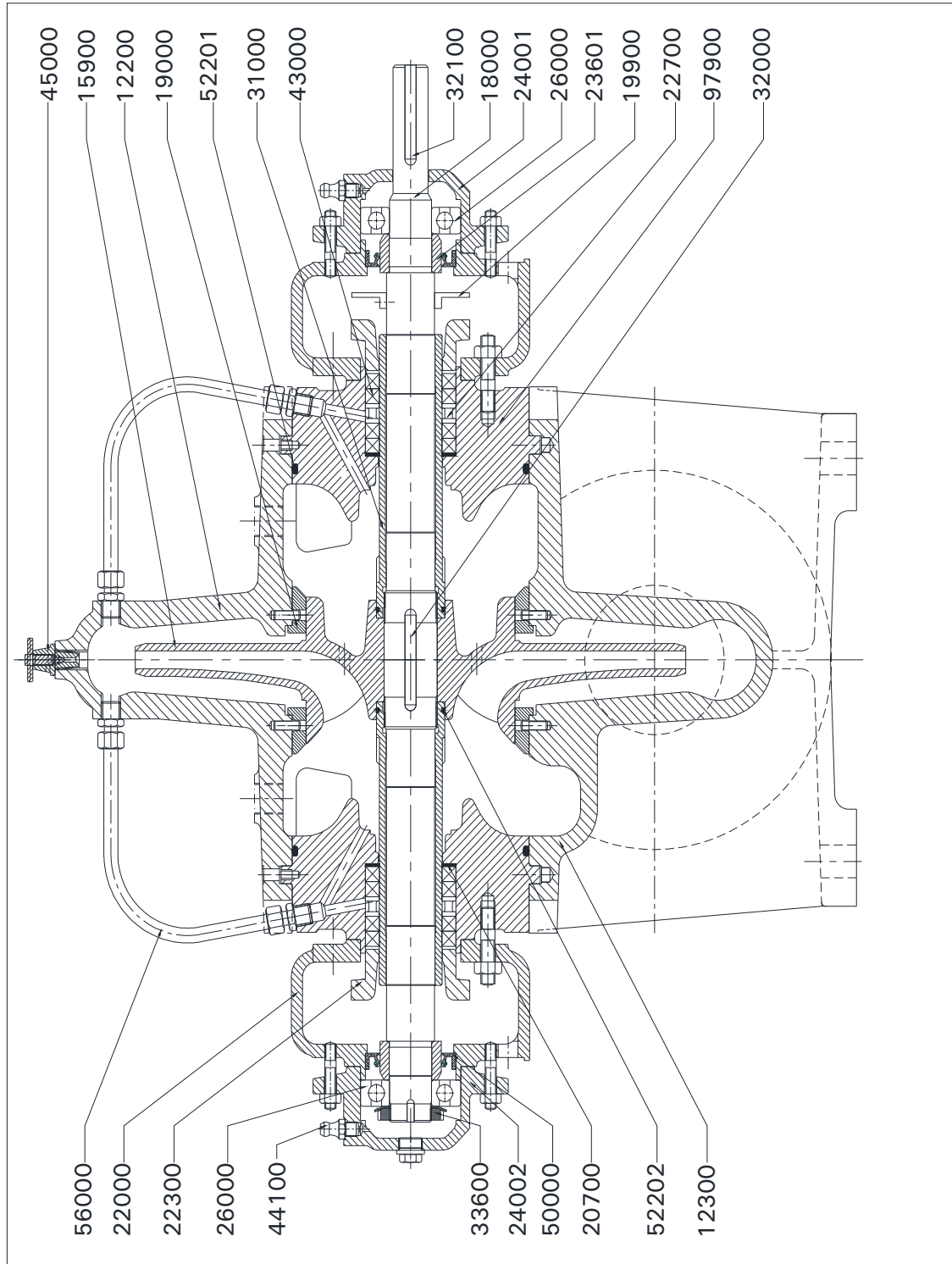


## Mechanical Seal Components

1810001*	PUMP SHAFT (MECH.SEAL)
2300001*	MECH.SEAL
3300001*	SHAFT-SLEEVE(MECH.SEAL)AGAINST ORDER
9790003	INSERT (MECH.SEAL)

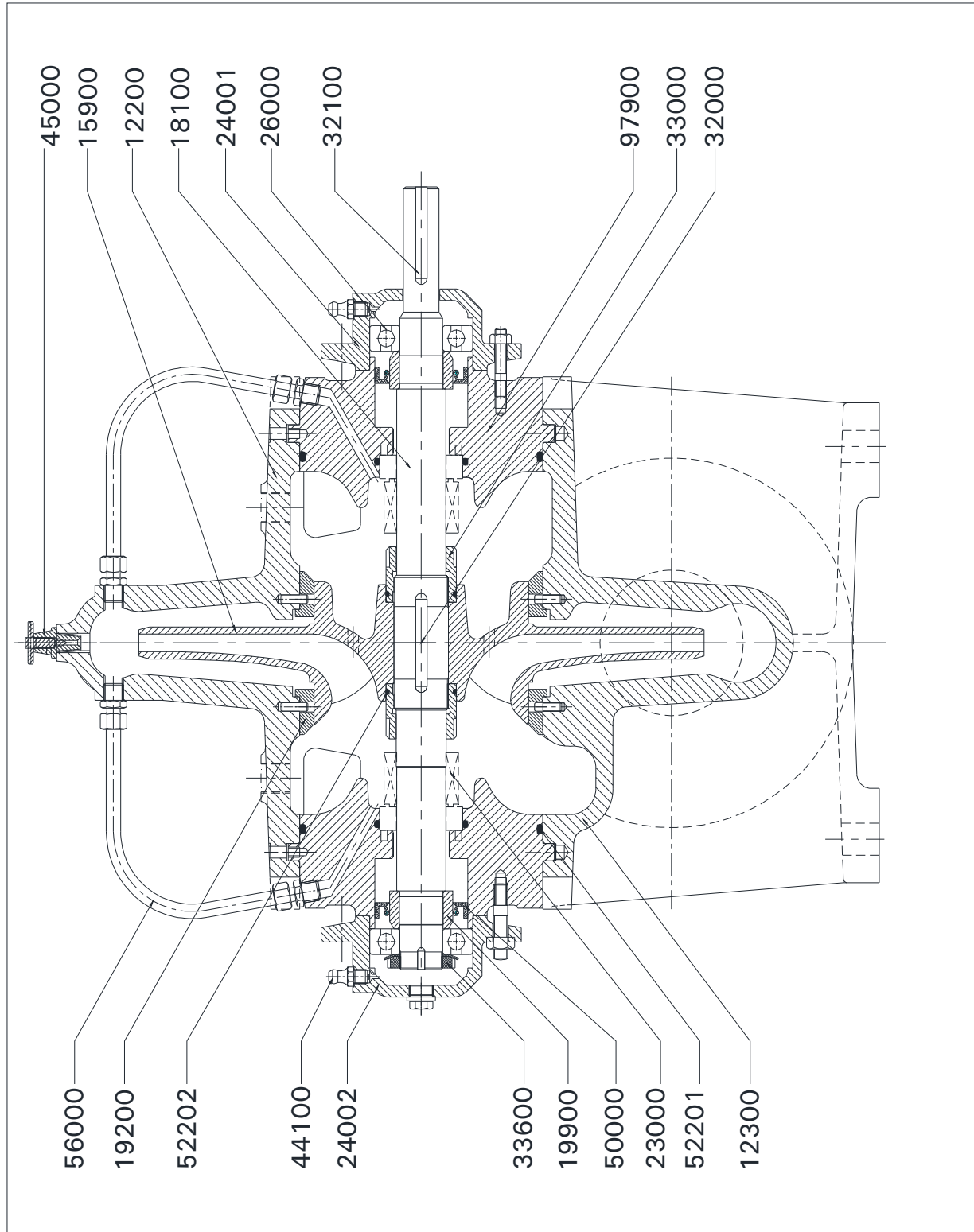


### CROSS SECTIONAL DRAWING FOR SCT50/38 & SCT80/38 (SOFT PACKED)



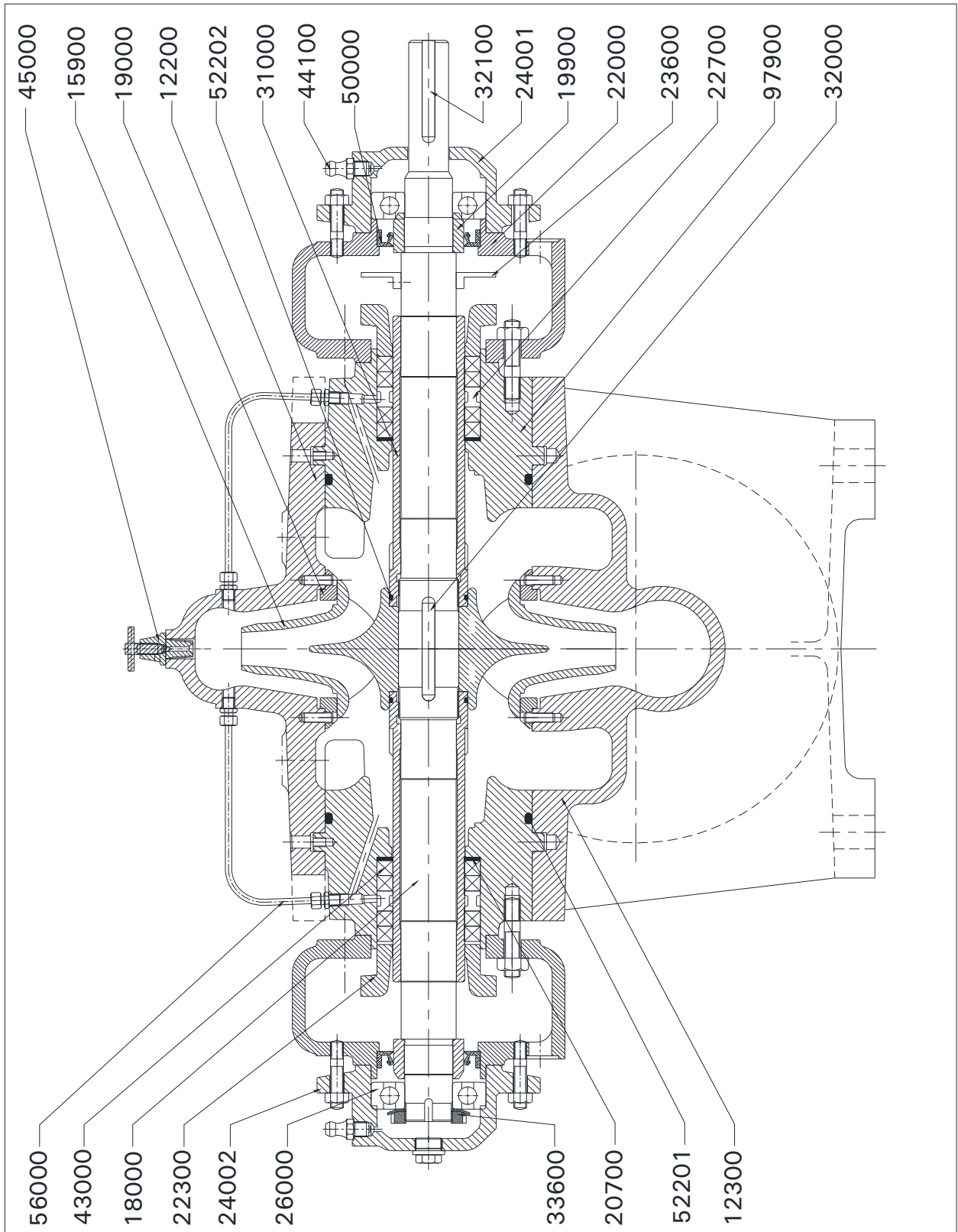


### CROSS SECTIONAL DRAWING OF SCT50/38 & SCT80/38 (MECHANICAL SEAL)



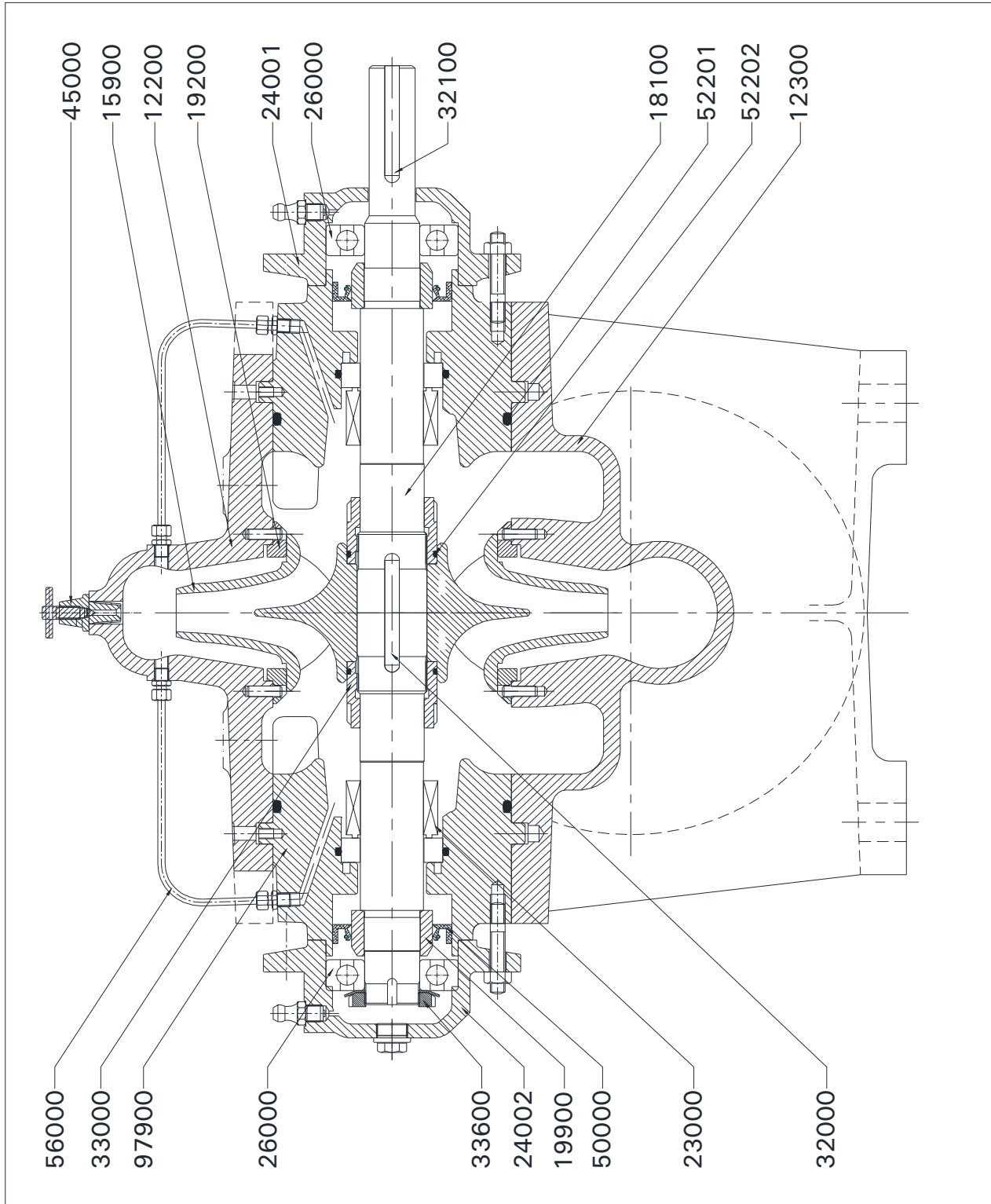


# CROSS SECTIONAL DRAWING FOR SOFT PACKED PUMP: MODULE I & II (EXCEPT SCT50/38 & SCT80/38)





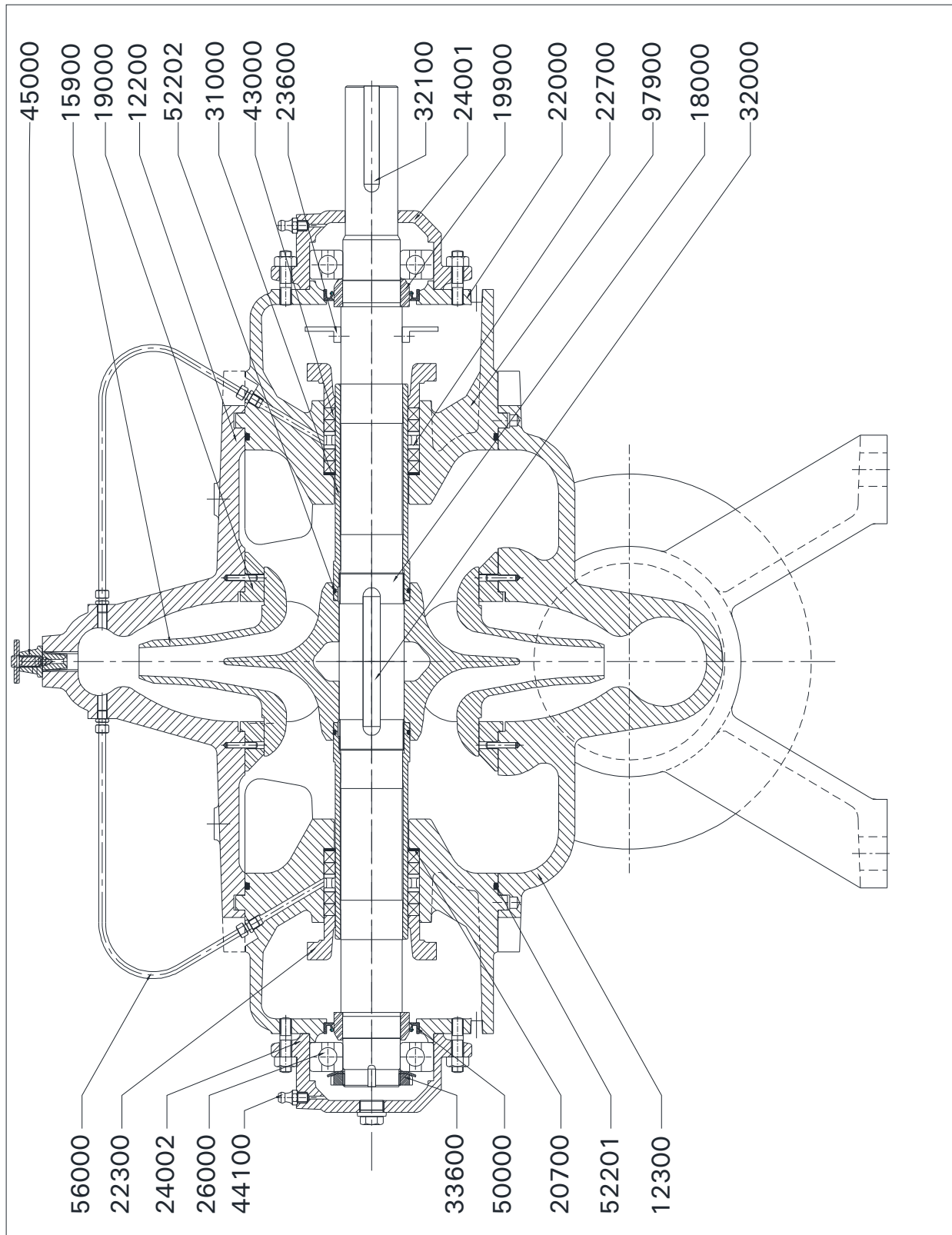
### CROSS SECTIONAL DRAWING FOR MECHANICAL SEAL PUMP: MODULE I, II & III (EXCEPT SCT50/38 & SCT80/38)





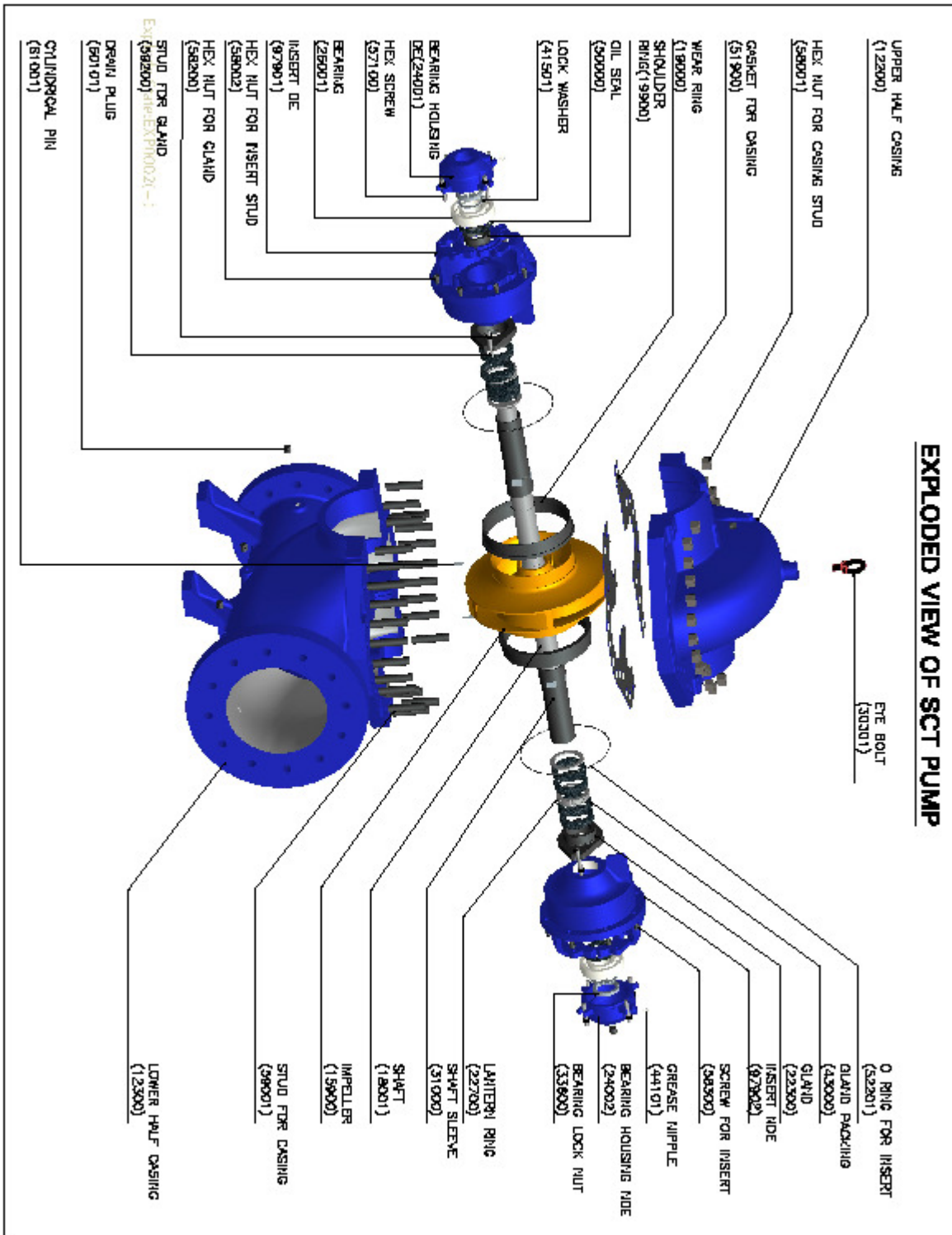


### CROSS SECTIONAL DRAWING FOR GLAND PACK PUMP : MODULE 3





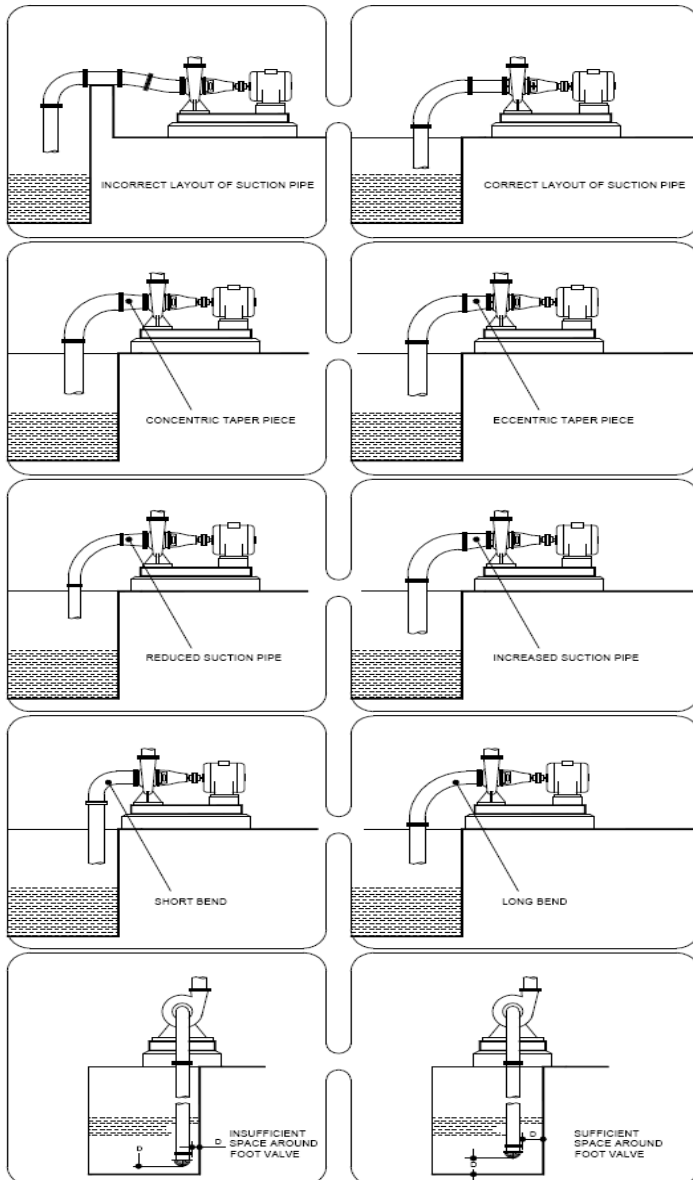
# 10.0 EXPLODED VIEW





INCORRECT

CORRECT



FOR RECOMMENDATIONS OF SUITABLE SUCTION AND DELIVERY PIPE SIZE PLEASE CONTACT OUR AUTHORISED DEALER OR NEAREST REGIONAL OFFICE

**GENERAL INSTRUCTIONS FOR INSTALLATION OPERATION & MAINTENANCE OF KIRLOSKAR CENTRIFUGAL PUMPS**

© Registered users – Kirlokar Brothers Ltd.

## GENERAL INSTRUCTIONS FOR INSTALLATION, OPERATION & MAINTENANCE OF

# KIRLOSKAR CENTRIFUGAL PUMPS

### WARNING

The equipment supplied is designed for specific capacity, speed, pressure and temperature. Do not use the equipment beyond the capacities for which it is manufactured. The equipment manufactured is also shop tested for the satisfactory performance and if it is operated in excess of the conditions for which it is manufactured, the equipment will be subject to excessive stresses and strains.

### LOCATION

The pump should be located as near the liquid source as possible. This will minimise the suction lift and pump will give better performance.

Ample space should be provided on all sides so that the pump can be inspected while in operation and can be serviced conveniently whenever required.

### FOUNDATION

The foundation should be sufficiently substantial to absorb any vibration and to form a permanent rigid support for the base plate. This is important in maintaining the alignment of a direct connected unit. A concrete foundation on a solid base is advisable. Foundation bolts of the proper size should be embedded in the concrete located by a drawing or template. A pipe sleeve about two and one-half diameter larger than the bolt should be used to allow movement for the final position of the foundation bolts.

### ALIGNMENT

Pumps and drivers that are supplied by the manufacturers, mounted on a common base plate are accurately aligned before despatch. However as the alignments are likely to be disturbed during transit to some extent and therefore must not be relied upon to maintain the factory alignment. Re-alignment is necessary after the complete unit has been levelled on the foundation and again after the grout has been set and foundation bolts have been tightened. The alignment must be checked after the unit is piped up and re-checked periodically.

### FLEXIBLE COUPLING

A flexible coupling will not compensate for misalignment of the pump and driver shafts. The purpose of the flexible coupling is to compensate for temperature changes and to permit the movement of the shafts without interference with each other while transmitting power from the driver to the pump.

### TYPE OF MISALIGNMENT (SEE FIGURE 1)

There are two types of misalignment between the pump shaft and the driver shaft.

- (a) Angular misalignment : Shafts with axis concentric but not parallel.
- (b) Parallel misalignment : Shafts with axis Parallel but not concentric.

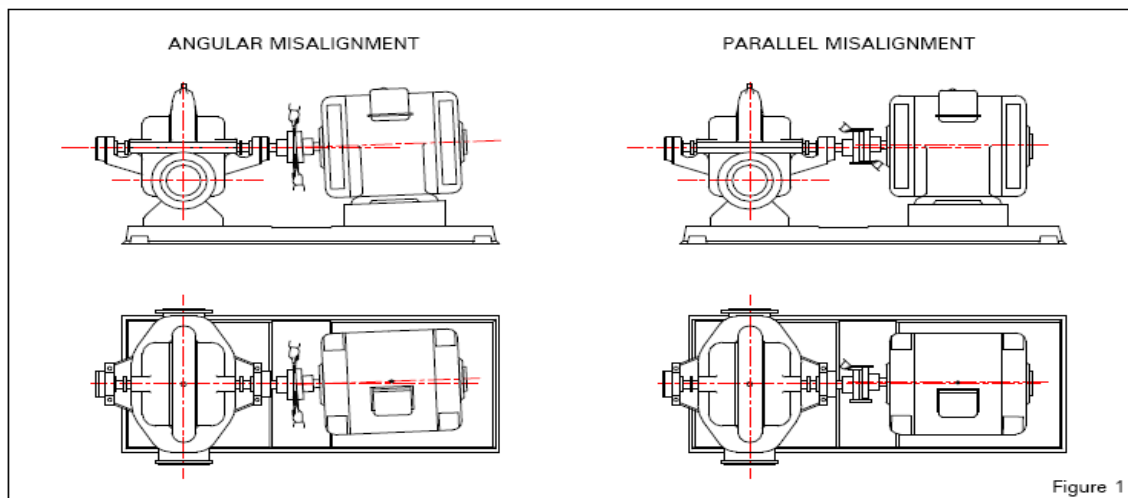


Figure 1

### LEVELLING THE UNIT

When the unit is received with the pump and driver mounted on the base plate, it should be placed on the foundation and the coupling halves disconnected. The coupling should not be reconnected until all alignment operations have been completed. The base plate must be supported evenly on wedges inserted under the four corners so that it will not be distorted or sprung by the uneven distribution of the weight. Adjust the wedges until the shafts of the pump and driver are in level. Check the coupling faces, suction and discharge flanges for the horizontal or vertical position by means of spirit level.

### FLEXIBLE COUPLING ALIGNMENT (SEE FIGURE 2)

The two halves of the coupling should be at least 4 mm apart so that they cannot touch each other when the driver shaft is rotated. Necessary tools for approximately checking are straight-edge and an outside caliper.

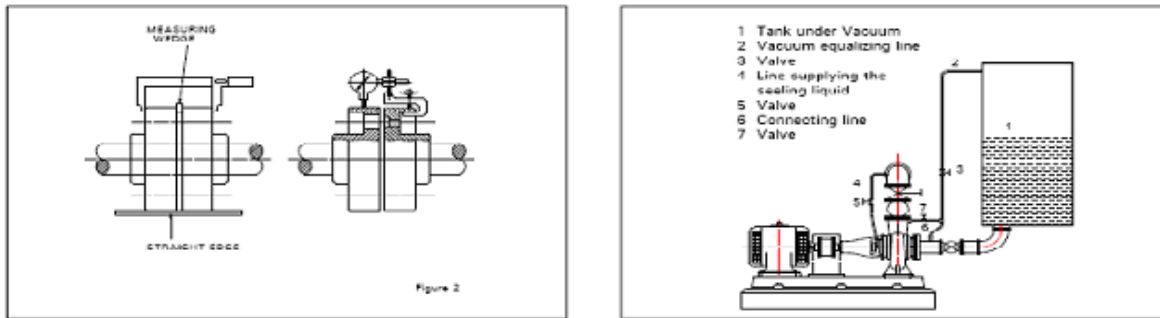


Figure 2

A check for parallel alignment is made by placing a straight-edge across both coupling periphery at the top, bottom and both the sides. The unit will be in parallel alignment when the straight-edge rests evenly on the coupling periphery at all positions. Care must be taken to have the straight-edge parallel to the axis of the shafts. Parallel alignment is correct when the measurements show that all points of the coupling faces are within  $\pm 0.2$  mm of each other.

A check for angular alignment is made by using an outside caliper across the width of the coupling races at various points. Angular alignment is correct when the measurements show that all points of the coupling faces are within  $\pm 0.2$  mm of each other.

Coupling alignment can be checked with dial gauge indicator as shown in Fig. 2.

#### GROUTING

When the alignment is correct, the foundation bolts should be tightened evenly but not too firmly. The unit can then be grouted by working soft concrete under the edges. Foundation bolts should not be fully tightened until the grout is hardened, usually 48 hours after pouring.

#### FACTORS THAT MAY DISTURB ALIGNMENT

The unit should be periodically checked for alignment. If the unit does not stay in line after being properly installed, the following are possible causes:

- (a) Setting, seasoning of the foundation
- (b) Pipe strains distorting or shifting the machines
- (c) Wear of the bearings

#### PIPING

Both suction and delivery pipes and accessories should be independently supported near the pump so that when the flanges bolts are tightened no strain will be transmitted to the pump casing. It is usually advisable to increase the size of both suction and delivery pipes at the pump nozzles in order to decrease the loss of head from friction and for the same reason piping should be arranged with as minimum bends as possible, as these should be made with along radius wherever possible. The pipe lines should be free from scales, welding residuals etc., and have to be mounted in such a way that they can be connected to suction and delivery flanges without any stress on the pump. Adequate supports should be given to pipe lines so that weight of the pipe lines does not fall on the pump. The use of minimum number of the bends and other fittings will minimise the frictional losses.

#### SUCTION PIPE

The suction pipe should be as short as possible. This can be achieved by placing the pump near the liquid to be pumped. The suction pipe must be kept free from air leaks. This is particularly important when the suction lift is high. A horizontal suction line must have a gradual rise to the pump. Any high point in the pipe will be filled with air and thus prevent proper operation of the pump. A concentric taper piece should not be used in a horizontal suction line as it forms an air pocket in the top of the reducer and the pipe. Use an eccentric piece instead.

The end of the suction pipe must be well submerged to avoid whirlpools and ingress of air but must be kept clear of any deposits of mud, silt, grit etc. The pipe must be clear from any side of wall by at least 450 mm. The end of the suction pipe should be provided with a strainer of sufficient open area.

#### DELIVERY PIPE

A check (non-return) valve and a gate or sluice valve (regulating valve) should be installed in the discharge line. The check valve placed between the pump and the gate valve is to protect the pump from excessive pressure and to prevent water running back through the pump in case of failure of the driving machine.

Discharge piping should be provided with a sluice valve adjacent to the delivery flange to control the discharge, if required.

#### VACUUM EQUALISING LINE (AND LIQUID LINE) (SEE FIGURE 3)

If the pump draws from a system under vacuum an equalising pipe must be carried from the highest point of the suction line, however, as close to the suction flange of the pump as possible, to the top of the feed tank to keep gas bubbles that might have been entrapped in the flow from entering the pump. The line should be fitted with an isolating valve which should be closed only for maintenance work on the pumpset.

Apply sealing liquid (external sealing) to the shaft seal cage to prevent entry of air in the case of pumps with packed stuffing box. It is convenient to tap the sealing liquid from the delivery line above the non-return valve.

## FOOT VALVE

It is advisable to install a foot valve to facilitate priming. The foot valve should have sufficient clear passage for water. Care must be taken to prevent foreign matter from being drawn into the pump or choking the foot valve and for this purpose an efficient strainer should be provided.

## STUFFING BOXES AND PACKING

Stuffing boxes should be carefully cleaned and the packing placed in them. Be sure that sufficient packing is placed at the back of the water seal cage. If the water to be pumped is dirty or gritty, sealing water should be piped to the stuffing boxes from clean outside source of supply in order to prevent damage to the packing and shaft. In placing the packing, each packing ring should be cut to the proper length so that ends come together but do not overlap. The succeeding rings of packing should not be pressed too tight as it may result in burning the packing and cutting the shaft. If stuffing box is not properly packed, friction in stuffing box prevents turning the rotor by hand. On starting the pump it is well to have the packing slightly loose without causing an air leak, and if it seems to leak, instead of putting too much pressure on the gland, put some heavy oil in the stuffing box until the pump works properly and then gradually tighten up the gland. The packing should be occasionally changed.

## BALL BEARINGS

Correct maintenance of ball bearings is essential. The bearing manufacturers give the following as a guide to relubrication periods under normal conditions.

Three monthly when on continuous duty.

Six monthly when on eight-hour per duty.

The bearings and housings should be completely cleaned and recharged with fresh grease after 2500 hours or the nearest pump overhaul time.

## PRIMING

No pumping action occurs unless the pump casing is filled with liquid. Pump casing and suction pipe must therefore be completely filled with the liquid and thus all air removed before the pump is started. Several different priming methods can be used depending on the kind of installation and service involved.

(1) Liquid level above pump level

Pump is set below liquid level of source of supply so that liquid always flows to pump under positive head.

(2) Priming with foot valve

(a) When pump is installed on suction lift with foot valve at the end of suction line, fill pump with water from some outside source till all air is expelled and water flows through air vent.

(b) When there is liquid under some pressure in the discharge pipe, priming can be effected by bypassing the pressure liquid around the check and gate valve. Of course, the initial priming must be effected from some outside source.

NOTE: in this case, the foot valve must be capable of withstanding pump pressure and possible surge.

(3) Priming by ejector: An ejector operated by steam, compressed air or water under pressure and connected to air vent on top of casing can be used to remove air from and prime the pump on suction lift installations.

(4) Priming by dry vacuum pump : a hand or power pump sucks in all the air from the casing and the suction pipe, and thus primes the system.

## STARTING

The pump must not be started without being primed. Be sure that the driver rotates in the proper direction as indicated by a direction arrow on the pump casing.

## RUNNING

On account of its simple construction, the centrifugal pump requires practically no attention while running. Lubrication of the bearings and manipulation of the glands are the only things that need attention from the operator.

## STOPPING

Before stopping the pump, close the gate valve. This will prevent water hammer on check valve.

## STUFFING BOXES

Do not tighten the glands excessively. A slight dripping of water from the stuffing boxes when pump is running keeps packing in good condition.

## CASING RINGS

Casing rings are fitted in the casing to reduce the quantity of water leaking back from the high pressure side to the suction side. These casing rings are fitted to maintain a small clearance and depend on the water in the pump for lubrication. When they are worn out, the clearance becomes greater and more water passes back into the suction. They must be replaced from time to time to restore the pump efficiency to its normal value.

**SPARE PARTS**

A set of ball bearings, a set of casing rings, and a set of gland packing rings must always be kept at hand to ensure uninterrupted service from the pump. While ordering for spare parts, always give type, size and serial number of the pumps as stamped on the name plate.

**PUMP TROUBLE**

When investigating trouble with Kirloskar pumps, always remember that pumps have been tested at the factory and are mechanically correct when sent out. Discounting the possibility of damage during transit, most of the trouble in the field is due to faulty installation. Investigation shows that the majority of troubles with centrifugal pumps result from faulty conditions on the suction side.

**BREAK DOWN-CAUSE-CHECK POINTS**

In case of breakdown we recommend the location of the fault by using the following table.

BREAKDOWN	CHECK POINTS									
Pump does not deliver	1 18	7 19	8 23	9 25	10 26	11 56	12 57	14 58	15	17
Pump delivers at reduced capacity	1 11 22	2 12 56	3 13 57	4 14 58	5 15	6 17	7 18	8 19	9 20	10 21
Delivery performance deteriorates	1 20	3 21	7 22	9 23	10 24	11 53	12 57	13 62	14	19
Pump delivers too much	16	56	57	58						
Delivery is interrupted	1 14 58	3 15 62	6 16	7 19	8 22	9 23	10 25	11 26	12 56	13 57
After stopping pump runs in reverse direction	52									
Very noisy	1 19	2 20	5 22	6 54	7 55	8 56	11 57	12 62	13	15
Unsteady running of pump	19 39 55	20 40 58	22 43	31 44	32 47	33 48	35 49	36 50	37 51	38 54
Stuffing box leaks excessively	24	27	28	29	30	31	47	48	49	53
Fumes from stuffing box	22 42	23 43	24	25	26	27	28	29	30	41
Pump rotor locked in standstill position	22	45	46	50						
Pump is heating up and seizing	23 42	24 45	25 47	26 48	27 49	28 50	29 54	30	40	41
Bearing temperature increases	19 37 47	20 38 48	21 39 49	22 40 51	31 41 54	32 42 55	33 43 58	34 44	35 45	36 46
Motor will not start	14	22	60							
Motor gets hot or burns out	14 58	22 59	27 60	28 61	40	43	50	55	56	57
Motor is difficult to start	14	22	27	28	45	46	50	58	59	60



# CHECK POINTS

1. Suction pipe, foot valve choked.
2. Nominal diameter of suction line too small.
3. Suction pipe not sufficiently submerged.
4. Too many bends in the suction line.
5. Clearance around suction inlet not sufficient.
6. Shut off valve in the suction line in unfavourable position.
7. Incorrect layout of suction line (formation of air pockets).
8. Valve in the suction line not fully open.
9. Joints in the suction line not leak-proof.
10. Air leaking through the suction line and stuffing box etc.
11. Suction lift too high.
12. Suction head too low (difference between pressure at suction connection and vapour pressure too low).
13. Delivery liquid contains too much gas and/or air.
14. Delivery liquid too viscous.
15. Insufficient venting.
16. Number of revolutions too high.
17. Number of revolutions too low.
18. Incorrect direction of rotation (electric motor incorrectly connected, leads of phases on the terminal block interchanged).
19. Impeller clogged.
20. Impeller damaged.
21. Casing rings worn out.
22. Separation of crystals from the flow of pumping liquid (falling below the temperature limit/equilibrium temp).
23. Sealing liquid line obstructed.
24. Sealing liquid contaminated.
25. Lantern ring in the stuffing box is not positioned below the sealing liquid inlet.
26. Sealing liquid omitted.
27. Packing incorrectly fitted.
28. Gland tightened too much/slanted.
29. Packing not suitable for operating conditions.
30. Shaft sleeve worn in the region of the packing.
31. Bearing worn out.
32. Specified oil level not maintained.
33. Insufficient lubrication of bearings.
34. Ball bearings over-lubricated.
35. Oil/Grease quality unsuitable.
36. Ball bearing incorrectly fitted.
37. Axial stress on ball bearings (no axial clearance for rotor).
38. Bearings dirty.
39. Bearings rusty (corroded).
40. Axial thrust too great because of worn casing rings, relief holes obstructed.
41. Insufficient cooling water supply to stuffing box cooling.
42. Sediment in the cooling water chamber of the stuffing box cooling.
43. Alignment of coupling faulty or coupling loose.
44. Elastic element of coupling worn.
45. Pump casing under stress.
46. Pipeline under stress.
47. Shaft runs untrue.
48. Shaft bent.
49. Rotor parts insufficiently balanced.
50. Rotor parts touching the casing.
51. Vibration of pipe work.
52. Non-return valve gets caught.
53. Contaminated delivery liquid.
54. Obstruction in delivery line.
55. Delivery flow too great.
56. Pump unsuitable for parallel operation.
57. Type of pump unsuitable.
58. Incorrect choice of pump for existing operating conditions.
59. Voltage too low/power supply overloaded.
60. Short circuit in the motor.
61. Setting of starter of motor too high.
62. Temperature delivery liquid too high.





## GENERAL INFORMATION & SAFETY INSTRUCTIONS

1. The products supplied by KBL have been designed with safety in mind. Where hazards cannot be eliminated, the risk has been minimized by the use of guards and other design features. Some hazards cannot be guarded against and the instructions below **MUST BE COMPLIED WITH** for safe operation. These instructions cannot cover all circumstances. Installation, operation and maintenance personnel must use safe working practices at all the times.

1.1 KBL products are designed for installation in designated areas, which are to be kept clean and free of obstructions that may restrict safe access to the controls and maintenance access points.

A pump duty nameplate is fitted to each unit and must not be removed. Loss of this plate could make identification impossible. This in turn could affect safety and cause difficulty in obtaining spare parts. If accidental loss or damage occur, contact KBL immediately.

1.2 Access to the equipment should be restricted to the person net responsible for installation, operation and maintenance and they must be trained, adequately qualified and supplied with appropriate tools for their respective tasks.

1.3 Most accidents involving product operation, maintenance and repair are caused by failure to observe safety rules or precautions. An accident can often be avoided by recognizing potentially situations before an accident occurs. A person must be aware of potential hazard associated in activities of installation, operation and maintenance of equipments.

1.4 KBL requires that, all personnel that are responsible for installation, operation or maintenance of the equipment, have access to and study the product instruction manual **BEFORE** any work is done and that they will comply with all local and industry based safety instructions and regulations.

1.5 Ear defenders should be worn where the specified equipment noise level exceeds locally defined safe levels. Safety glasses or goggles or face shield should be worn where working with pressurized systems and hazardous substances. Other personal protection equipment must be worn where local rules apply. Wear safety shoes, helmets and cotton overall [Apron] when you enter pump house. Noise level should not exceed 90 dbA and 110 dbA for motor driven and engine driven pumps, respectively.

1.6 Do not wear loose clothing or jewelry, which could catch on the controls or become trapped in the equipment.

1.7 Read the instruction manual before installation, operation or maintenance of the equipment. Check and confirm that you are referring relevant copy of the manual by comparing pump type on the nameplate and with that on the manual.

1.8 Note the "Limits of product application permissible use" specified in the manual. Operation of the equipment beyond these limits will increase the rist from hazards noted below and may lead to premature and hazardous pump failure.

1.9 Clear and easy access to all controls, gauges and dials etc must be maintained at all times. Hazardous or flammable materials must not be stored in pump rooms unless safe areas or racking and suitable container have been provided.

1.10 Use suitable earthing and tripping devices for electrical equipments.

2. **IMPROPER INSTALLATION, OPERATION, MAINTENANCE, LUBRICATION, REPAIR OF THIS KBL PRODUCT COULD RESULT IN INJURY OR DEATH.**

If any tool, procedure, work method and operation technique is not recommended by KIRLOSKAR BROTHERS LIMITED is used or followed, it should be ensured that it is a safe for personnel around and others. It should also be ensured that the product will not be damaged or made unsafe by the operation, lubrication and maintenance or repair procedures you choose.



### 3. SAFETY INSTRUCTIONS WHILE HANDLING AND STORAGE

When lifting the pump, use the lifting points specified on general arrangement drawing, if provided. Use lifting equipment having a safe working load rating suitable for the weight specified. Use suitable slings for lifting pump, which is not provided, with lifting points. The use of forklift truck and chain crane sling equipment is recommended but locally approved equipment of suitable rating may be used. While lifting, the equipment adjusts the center of gravity, so that it is balanced properly.

Do not place fingers or hands etc into the suction or discharge pipe outlets and do not touch the impeller, if rotated this may cause severe injury. To prevent ingress of any objects, retain the protection covers or packaging in place until removal is necessary for installation. If the packaging or suction and discharge covers are removed for inspection purposes, replace afterwards to protect the pump and maintain safety.

### 4. SAFETY INSTRUCTIONS WHILE ASSEMBLY & INSTALLATION

Shaft alignment must be checked again after the final positioning of the pump unit and connection to pipe work as this may have disturbed the pump or motor mounting positions. If hot liquids [above 80°C] are being pumped, alignment should be checked and reset with the pump and motor at their normal operating temperature. If this is not possible, KBL can supply estimated initial offset figures to suit extreme operating temperatures. Failure to support suction and delivery pipe work may result in distortion of the pump casing, with the possibility of early pump failure.

### 5. SAFETY INSTRUCTIONS WHILE COMMISSIONING & OPERATION

Never attempt adjustments while the pump is running, unless otherwise specified in the operation, maintenance manual.

Do not touch any moving or rotating parts. Guards are provided to prevent access to these parts, where they have been removed for maintenance they must be replaced before operating the equipment.

Check that pump is primed. Pump should never be run dry as the pumped liquid acts as lubricant for the close running fits surrounding impeller and damage will be incurred.

Failure to supply the stuffing box or mechanical seal with cooling of flush water may result in damage and premature failure of the pump.

Do not touch surfaces, which during normal running will be sufficiently hot to cause injury. Note that these surfaces remain hot after the pump has stopped, allow sufficient time for cooling before maintenance. Be cautious and note that other parts of the pump may become hot if a fault is developing.

Do not operate water pumps in temperatures below freezing point, without first checking that the pumped fluid is not frozen and the pump is free to turn. Pumps in these environments should be drained down during inactivity and re-primed before starting.

In addition to local or site regulations for noise protection, KBL recommend the use of personal ear protection equipment in all enclosed pump rooms and particularly those containing diesel engines. Care must be taken to ensure that any audible alarm or warning signal can be heard with ear defenders worn.



Be aware of the hazards relating to the pump fluid, especially the danger from inhalation of noxious and toxic gases, skin and eye contact or penetration. Obtain and understand the hazardous substance data sheets relating to the pumped fluid and note the recommended emergency and first aid procedures.

## 6. SAFETY INSTRUCTIONS WHILE MAINTENANCE & SERVICING

Do not attempt repairs of the pump or its accessories which you do not know. Use proper tools.

Before attempting any maintenance on a pump particularly if it has been handling any form of hazardous liquid, it should be ensured that the unit is safe to work on. The pump must be flushed thoroughly with suitable cleaner to purge away any of the product left in the pump components.

This should be carried out by the plant operator and a certificate of cleanliness obtained before starting work. To avoid any risk to health it is also advisable to wear protective clothing as recommended by the site safety officer especially when removing old packing, which may be contaminated.

Isolate the equipment before any maintenance work is done. Switch off the main supply, remove fuses, apply lockouts where applicable and affix suitable isolation warning signs to prevent inadvertent reconnection. In order to avoid the possibility of maintenance personnel inhaling dangerous fumes or vapors locations by removal of bearing housing and shaft assembly to a suitable maintenance area.

Check and ensure that the pump operates at below the maximum working pressure specified in the manual or on the pump nameplate and before maintenance, ensure that the pump is drained down.

Wear a suitable mask or respirator when working with packing and gasket contain fibrous material, as these can be hazardous when the fibrous dust is inhaled. Be cautious, if other supplier's components have been substituted for genuine KBL parts, these may then contain hazardous materials.

Store all oily rags or other flammable material in a protective container in a safe place. Do not weld or flame cut on pipes/tubes that contents flammable fluids. Clean them thoroughly with nonflammable solvent before welding or flame cutting on them. Use solvent/chemical resistant gloves for hand protection.

**Dispose of all wastes like gaskets, gland packing, oil, batteries, packing material etc in accordance with local regulation.**

Adequacy of suitable crane should be checked before lifting the pump/pump components. Also condition of pulleys, chain and lifting shackles should be checked before use.

**ADDRESSES OF REGIONAL OFFICE****AHMEDABAD**

11, Mill Officers Colony,  
Behind La Gajjar Chambers,  
Ashram Road, Ahmedabad 380 009  
Tel: +91-79-26583739, 26580376,  
26583615, 26583258, 26574500, 26574802  
Fax: +91-79-26583786  
EMAIL ID: [ahmedabad@kbl.co.in](mailto:ahmedabad@kbl.co.in)

**BANGALORE**

No.5, Lakshmi Complex, II floor, 10th Cross,  
RMV Extension, CV Raman Road Bangalore 560  
080  
Tel: +91-80-23619914, 23619915, 23610027,  
23610028  
Fax: +91-80-23610095  
EMAIL ID: [bangalore@kbl.co.in](mailto:bangalore@kbl.co.in)

**BHOPAL**

E-1, Shankarnagar, 6 1/2 Bus Stop,  
Opposite Parul Hospital, Bhopal 462 016  
Tel: +91-0755-4218341  
EMAIL ID: [bhopal@kbl.co.in](mailto:bhopal@kbl.co.in)

**BHUBANESHWAR**

Plot No. 969, Part A, Uttam Tower, Block B, 1st  
Floor, Ashok Nagar, Unit 2,  
Bhubaneswar 751 009  
Tel: +91-0674-2536188, 2536421, 2535371  
Fax: +91-0674-2534965  
EMAIL ID: [bhubaneswar@kbl.co.in](mailto:bhubaneswar@kbl.co.in)

**CHENNAI**

RAJ PARIS, Trimeni Towers, 2nd Floor,  
147 GN Chetty Road, T Nagar,  
Chennai 600 017  
Tel: +91-044-28157769, 28156546 / 7 / 8  
Fax: 044-28156549  
EMAIL ID: [chennai@kbl.co.in](mailto:chennai@kbl.co.in)

**JAIPUR**

B-8, Durga Das Colony,  
Behind Neelkanth Tower,  
Bias Godam Circle,  
Bhawani Singh Road,

Jaipur - 302001 - Rajasthan  
Tel: +91-0141 - 2223830  
EMAIL ID: [jaipur@kbl.co.in](mailto:jaipur@kbl.co.in)

**KOCHI**

Veejay Towers, 38/239 A, Salim Rajan Road,  
Gandhinagar, Ernakulam,  
Kochi - 682 017  
Tel: +91-0484-2206651, 2206652  
Fax: +91-0484-2206653  
EMAIL ID: [kochi@kbl.co.in](mailto:kochi@kbl.co.in)

**JAMSHEDPUR**

No. 4, 4th Floor, Meghdeep Building,  
Q road, Bistupur, Beside Hotel South Park,  
Jamshedpur - 834001

**KOLKATA**

KCI Plaza, 1st Floor,  
23 C, Ashutosh Chowdhary Avenue  
Kolkata 700 019  
Tel: +91-033-2461 4040, 4050, 4060, 5065,  
5934, 5325, 4615  
Fax: +91-033-2461 4519  
EMAIL ID: [kolkata@kbl.co.in](mailto:kolkata@kbl.co.in)

**LUCKNOW**

B-1/7, Sector A, Aliganj  
Lucknow 226 024  
Tel: +91-0522-2326367, 2326374,  
2326387  
Fax: +91-0522-2326365  
EMAIL ID: [lucknow@kbl.co.in](mailto:lucknow@kbl.co.in)

**MUMBAI**

10, Corporate Park,  
Swastik Mills Compound,  
Sion-Trombay Road, Chembur  
Mumbai 400 071  
Tel: +91-022-25289320 to 28  
Fax: +91-022-25289329  
EMAIL ID: [mumbai@kbl.co.in](mailto:mumbai@kbl.co.in)

**NEW DELHI**

Jeevan Tara Building,  
5, Parliament Street,



New Delhi 110 001

Tel: +91-011-41501055 to 62

Fax: +91-011-23342002

EMAIL ID: [delhi@kbl.co.in](mailto:delhi@kbl.co.in)

### **NAGPUR**

Flat No. 7, Sagar Palace, Laxmi Nagar,  
Behind 'Bal Jagat', East High Court Road,  
Nagpur - 440 022

Tel: +91-0712-2234275, 2234276

Fax: +91-0712-2234276

EMAIL ID: [nagpur@kbl.co.in](mailto:nagpur@kbl.co.in)

### **PUNE**

Udyog Bhavan, Tilak Road,  
Pune 411 002 (India)

Fax: +33 (0) 1 34 66 07 33

EMAIL ID: [pune@kbl.co.in](mailto:pune@kbl.co.in)

Tel: +91-020-2444 0770

### **SECUNDERABAD**

P.O. Box. No. 1580, 403, Jade Arcade,  
126 MG Road, Paradise Circle,  
Secunderabad - 500 003

Tel: +91-040-66874700, 66874712 to 37, 27816075

Fax: +91-040-27894598

EMAIL ID: [secunderabad@kbl.co.in](mailto:secunderabad@kbl.co.in)



**KIRLOSKAR BROTHERS LIMITED**

Thuduea Rd, Near Simoung Shell Gas Station, Ban Thatkhao, Sisattank Dist Vientiane-Lao PDR

Tel: +856-21-219761

Fax: +856-21-213058

✉ : kbllaos@laotel.com

👤 : Tamil Selevan

: C.A.J. Vinodh

**KIRLOSKAR BROTHERS LLC**

15251 SW 108 Terrace  
Miami, – FL – 33196  
United States of America

Tel : +1 305-484-9509

✉ : santoshk.kulkarni@kbl.co.in

👤 : Santosh Kulkarni

**KIRLOSKAR BROTHERS (THAILAND) LIMITED**

Kirloskar Brothers (Thailand) Limited 18/8, 8th Floor,  
Fico Place Building, Sukhumvit 21 (Soi Asoke), Klong  
toey Nua, Wattana, Bangkok 10110, Thailand

Tel : +66 2 665 2781/2

✉ : pumps@kirloskarthailand.com

👤 : Shreekanth Ramaswami

**BRAYBAR PUMPS (PTY) LIMITED**

5 Indiana Street, Apex Industrial Area, Benoni, Gauteng, Republic of South Africa

Tel: +27 (0)11 421 5903/ +27 (0)11 421 5904

Fax: +27 (0)11 421 6793

✉ : ajeet@braybar.co.za/

braybar@global.co.za

Website: www.braybar.edx.co.za

👤 : Ajeet Kulkarni

**SPP PUMPS, INC.**

6716 Best Friend Road,  
Norcross, GA 30071,  
United States of America

Tel: +1(770) 409-3280

Fax: +1(770) 409-3290

✉ : john\_kahren@spppumps.com

👤 : John Kahren

(Business Manager)

**SPP PUMPS LIMITED**

P O Box 61491,  
Jebel Ali, Dubai  
United Arab Emirates

Tel: +971 (0) 4 8838 733

Fax: +971 (0) 4 8838 735

✉ : general@spppumps.com

👤 : Steven Keen

(General Manager)

**SPP PUMPS FRANCE**

2, rue du Chateau d'eau, 95450 US  
France

Tel: +33 (0) 1 30 27 96 96

Fax: +33 (0) 1 34 66 07 33

✉ : tima@spppumps.com

**SPP PUMPS (MENA) LLC**

Block 234, Road 36,  
6th October City  
Egypt

Tel: +202 38334150

Fax: +202 38334151

👤 : Eric Reidy

(General Sales Manager)

✉ : eric\_reidy@spppumps.com

Mobile: +2 01114277776

👤 : Ahmed Ali Soliman

(Senior Technical Engineer)

✉ : ahmed\_soliman@spppumps.com

Mobile: +2 01114266667

Website: www.spppumps.com



Enriching Lives

### **KIRLOSKAR KENYA LIMITED**

P. O. BOX 60061-0200

Nairobi, Kenya.

Tel: + 2542053 3421,6632, 6633, 6634

Fax: + 254-20-533390

Mobile: + 254-722815398,

+ 254-734148241

✉: rspatil@kirloskar.co.ke

👤: Rajkumar Patil

### **KIRLOSKAR BROTHERS LIMITED**

Office No 18,Hotel Cambodiana,

Sisowath Quay,Phnom Penh

Kingdom of Cambodia

Tel: + 855-99-614821

✉: tamil.s@kirloskarthailand.com

👤: Tamil Selven

### **KIRLOSKAR BROTHERS EUROPE BV**

Rooswijkweg 7-9,

1951 MD Velsen-Noord,

The Netherlands

Tel: + 31 (0) 251 270000

Fax: + 31 (0)251 272415

✉:info@kirloskar.eu

👤: Frank Korf , Varinder Dhoot

Website: www.kirloskarpumps.eu

### **KIRLOSKAR BROTHERS (THAILAND) LIMITED- RO Hanoi**

6th Floor, Regus press club building 59A,

Ly thai To,

Hoan Kiem Dist, Hanoi

Tel: + 84-902206662

✉: tamil.s@kirloskarthailand.com

👤: Tamil Selevan

### **SPP PUMPS LIMITED (UK HEADQUARTERS)**

Theale Cross, Pincents Lane,

Calcot, Reading, Berkshire

England, RG31 7SP

Tel : + 44(0)118 9323123

Fax: + 44(0)118 9323302

✉: solutions@spppumps.com

### **SPP PUMPS LIMITED**

10 Anson Road, #34-06

International Plaza.

Singapore 079903.

Tel: + 65 6226 1937

Fax: + 65 6226 2985

✉: solutions@spppumps.com

👤: Andy Gan

(Regional Sales Manager)

### **SPP PUMPS**

Sterling Fluid Systems (SA) (Pty) Ltd

6 B and C Roller Street, Spartan ext 17,

Kempton Park, RSA, 1619

Tel: + 27 (0) 860777786

Fax: + 27 (0) 860777781

✉: lvw@spppumps.co.za

👤: Louis van Wyk

(Managing director)

👤: Patrick Hindry

(General Sales Manager)

### **KIRLOSKAR BROTHERS LIMITED (EGYPT BRANCH OFFICE)**

1351, Corniche El Nile, Sahel, Shubra

Cairo, Egypt

Tel: + 202 24305296

Fax: + 202 24328927

👤: Narayan A. Mirji

✉: narayan.mirji@kbl.co.in

Website:www.kbl.co.in