

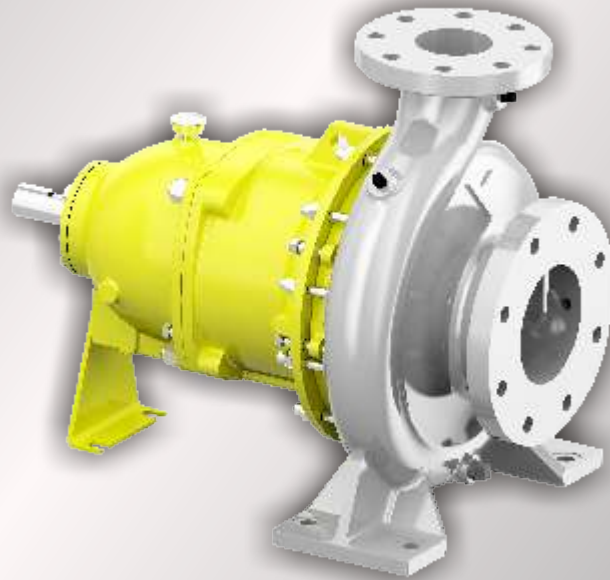

Enriching Lives

Instructions on installation,  
operation and maintenance for  
Kirloskar Magnetic Drive Pump - "ROMAK"



**KIRLOSKAR BROTHERS LIMITED**

A Kirloskar Group Company

Established 1888



Enriching Lives

## **KIRLOSKAR BROTHERS LIMITED**

REGD. OFFICE UDYOG BHAVAN, TILAK ROAD PUNE-411002

# **WARRANTY**

**We warrant that the pump supplied from us is free from defective material and faulty workmanship. This warranty holds good for a period of 12 months from the date of commissioning the equipment or 18 months from the date of dispatch from our factory, whichever is earlier. Our liability in respect of any complaint is limited to replacing part/parts free of charge ex-works or repairs of the defective part/parts only to the extent that such replacement / repairs are attributable or arise solely from faulty workmanship or defective material.**

**This warranty holds good only for the products manufactured by us.**

**KIRLOSKAR BROTHERS LIMITED**



Enriching Lives

## **CONTENTS**

**PART A: SAFETY MANUAL**

**PART B: INSTRUCTIONS ON INSTALLATION, OPERATION AND  
MAINTENANCE FOR KIRLOSKAR PUMP TYPE RMK**

**1. GENERAL**

**2. SAFETY INSTRUCTIONS**

**3. EQUIPMENT SCHEDULE**

**3.1 INSTALLATION**

**3.2 MOUNTING & ALIGNMENT**

**4. OPERATION**

**4.1 EQUIPMENT DESCRIPTION.**

**4.2 EQUIPMENT OPERATION.**

**5. MAINTENANCE MANUAL.**

**5.1 MAINTENANCE EHS INSTRUCTIONS**

**5.2 GENERAL MAINTENANCE DOCUMENTS**

**5.3 PREVENTIVE MAINTENANCE**

**5.4 CORRECTIVE MAINTENANCE**

**6 TECHNICAL DATA**

Note: A copy of **General instructions for installation, operation & maintenance of 'Kirloskar pumps'** is attached at the end of this manual.

For latest Manual Copy contact our Sales person or visit our website at [www.kirloskarpumps.com](http://www.kirloskarpumps.com)



Enriching Lives

## PART A: SAFETY MANUAL

### TRAINING

It is recommended, and a part of the CE regulations that users personnel who will be involved in the installation, operation and/or maintenance of KBL products should have the opportunity of an initial training period, which can be carried out either at KBL works or customers premises by arrangement.

This training is offered by KBL in 3 different forms.

- A.** Informal training in your maintenance workshop by our Technical Sales Representative on a Free of Charge basis.
- B.** Formal training in your training rooms by our skilled training personnel using visual aids, 'hands on' equipment etc, at an agreed cost to be confirmed.
- C.** Formal training at KBL Premises by our skilled training personnel using visual aids, 'hands on' equipment, etc, at an agreed cost to be confirmed.

**It is your responsibility to request your preferred training method now. KBL will not consider responsibility for ongoing breakdowns etc, if training has not been given.**

**KBL offer a friendly after sales policy but, reserve the right to charge for "call out" visits that are found to be caused through operator/fitter error.**

### LIMITATIONS OF USE

KBL products are designed to provide performance generally, as shown in accompanying literature associated with the individual models or series. All performance figures are given in good faith and are based on tests at KBL works using water at ambient temperature.

Operating temperatures are governed by the materials of construction of parts i.e. bearings, SSiC bearings, magnets, can etc, and it is the installer's responsibility to ensure that these maximum temperatures are not exceeded under any circumstances.

Performance figures provided by KBL against individual enquiries are estimates only, and are subject to variations depending upon data provided by client, and to head losses due to pipe work, valves, etc which may be unknown to KBL estimators.

All performance figures, temperatures, flow rates, dimensions & other details are subject to change without notice. Due to the wide variety of products handled by KBL pumps, it is impossible for KBL to give a firm recommendation regarding materials of construction for pump components. It is the users or specifiers responsibility to determine the effect of corrosion & abrasion, and the general suitability of any pump supplied for any individual application. KBL will, however, give advice in such material selection as it may be able to do so in good faith.

### ESSENTIAL SAFETY REQUIREMENTS (ESR)

All KBL products that are certified to comply with the Directive also carry a specific Safety Manual which must be referred to in conjunction with this manual. It is the responsibility of the user to ensure that the equipment is correctly rated for the environment in which it is to be used.

When handling KBL products, please refer weights given in KBL literature. Lifting equipment may be required in certain cases. Note that all pumps dispatched from our works are tested with water and during storage, packing and installation, some water will have remained in the pump body. This water may cause Spillage during handling. Water could react with the products you wish to pump, and it is user responsibility to check this before putting the



Enriching Lives

pump into operation. Water may also freeze if the pump is exposed to sub zero temperatures. Do not operate the pump under these conditions as ice inside the pump may cause damage to working parts of the pump.

At all times the installer must wear suitable clothing, footwear, goggles, etc for personal protection. This particularly applies when the pump is being operated or maintained.

If the product being processed is hazardous, then provision must be made by the user to deal with this problem. This can be achieved by either specifying a guardian or barrier system as part of the original pump specification and constructing pipe work which can carry the leakage to a safe place. It is end user responsibility to comply industry safety standards.

## **SAFETY MANUAL**

For Centrifugal RMK Pumps and Accessories User Instructions:

To be read in conjunction with

### **1.0 GENERAL**

These instructions must always be kept close to the product's operating location or directly with the Product. These instructions are intended to facilitate familiarization with the product and its permitted use to help satisfy safety requirements.

The instructions may not have taken into account local regulations; ensure such regulations are observed by all, including those installing the product. Always co-ordinate repair activity with operations personnel, and follow all plant safety requirements and applicable safety and health/law regulations. These instructions should be read prior to installing, operating, using and maintaining the equipment in any region worldwide and in conjunction with the main user instructions provided. The equipment must not be put into service until all the conditions relating to safety instructions have been met.

#### **A.1**

It is a legal requirement that machinery and equipment put into service within certain regions of the world shall conform to the applicable CE Marking Directives for Equipment for Potentially Explosive Atmospheres (ATEX).

Where applicable the Directive covers important safety aspects relating to the equipment, its use and the satisfactory provision of technical documents. Where applicable this document incorporates information relevant to these Directives. To establish if the product itself is CE marked for a Potentially Explosive Atmosphere check the nameplate and the Certification provided.

##### **A.1.1 Disclaimer**

Information in these User Instructions is believed to be reliable. In spite of all the efforts of KIRLOSKAR BROTHERS LTD. to provide sound and all necessary information, the content of this Manual may appear insufficient and is not guaranteed by KIRLOSKAR BROTHERS LTD. as to its completeness or accuracy. However KIRLOSKAR BROTHERS LTD will not accept responsibility for physical injury, damage, loss of user production by failure to observe the instructions for installation, operation and maintenance contained in this complete Manual.

##### **A.2 Personnel qualifications and training**

All personnel involved in the operation, installation, inspection and maintenance of the unit must be qualified to carry out the work involved. If the personnel in question do not already possess the necessary knowledge and skill, appropriate training and instruction must be provided. If required the operator may commission the manufacturer/supplier to provide applicable training.



Enriching Lives

### **A.3 CE Marking & Approvals**

General:

It is a legal requirement that the machinery & equipment put into service in certain region of the world shall conform with the applicable CE marking directives covering pump, accessories & instruments in the package.

Kirloskar pumps RMK range of pumps are certified to comply with the European Directive 2006/42/EC.

Check the product nameplate & certification provided to establish that the product itself is CE marked for Potentially Explosive Atmosphere.

### **A.4 Avoiding excessive surface temperatures**

ENSURE THE EQUIPMENT TEMPERATURE CLASS IS SUITABLE FOR THE HAZARD ZONE if applicable.

#### **A.4.1 Pump liquid temperature**

The surface temperature of the pump may be influenced by the temperature of the liquid handled. The temperature rise at ball bearings, liquid temperature and due to the minimum permitted flow rate is taken into account in the temperatures.

Maximum permitted pumping liquid temperature for RMK pumps is 180°C.

Maximum permitted temperature of casing, casing cover surface depends of material of construction. However same should not be exceed maximum permitted pumping liquid temperature.

Where there is any risk of the pump being run for prolonged periods against a closed or partially closed valve generating high liquid and casing external surface temperatures, **it recommended that users fit an external surface temperature protection device.**

#### **A.4.2 Additional requirements for dry run protection conditions**

Where the system operation does not ensure control of priming, and the bearings will run dry, in this case temperature of surface could be exceeded than normal, it is recommended for users to fit an external dry run protection device.

### **A.5 Preventing the build up of explosive mixtures**

ENSURE PUMP IS PROPERLY FILLED WHENEVER POSSIBLE AND DOES NOT RUN DRY IN ANY CASE.

Ensure the pump and relevant suction and discharge pipeline system is totally filled with liquid during the pumping operation, so that an explosive atmosphere is prevented. If the operation of the system cannot avoid this condition, ensure that the pump does not run dry IN ANY GIVEN CASE.

To avoid potential hazards from fugitive emissions of vapour or gas to atmosphere the surrounding area must be well ventilated.

### **A.6 Preventing sparks**

To avoid the potential hazard from random induced current generating a spark, the earth stud on the pump casing or foot must be connected. Avoid electrostatic charge: Do not rub non-metallic surfaces with a dry cloth for cleaning etc; ensure the cloth is damp.

### **A.7 Preventing leakage**

The pump must only be used to handle liquids for which it has been approved to have the correct corrosion resistance. Avoid entrapment of liquid in the pump and associated piping due to closing of suction and discharge valves, which could cause dangerous excessive pressures to occur if there is heat input to the liquid. This can occur particularly if the pump



Enriching Lives

is stationary. Bursting of liquid containing parts due to freezing, must be avoided by draining or protecting the pump and ancillary systems. If leakage of liquid to atmosphere can result in a hazard, the installation of a liquid detection device is recommended.

#### **A.8 Maintenance of the RMK pump to avoid the hazard**

**CORRECT MAINTENANCE IS REQUIRED TO AVOID POTENTIAL HAZARDS WHICH GIVE A RISK OF EXPLOSION**

The responsibility for compliance with maintenance instructions is with the plant operator. To avoid potential explosive hazards during maintenance, the tools, cleaning and painting materials used must not give rise to sparking or adversely affect the ambient conditions. Where there is a risk from such tools or materials, maintenance must be conducted in a safe area.

It is recommended that a maintenance plan and schedule is adopted, in line with the user instructions provided, to include the following:-

- A:- Any auxiliary systems installed must be monitored, if necessary, to ensure they function correctly.
- B:- Check for any leaks from gaskets.
- C:- Check that the duty condition is in the safe operating range for the pump.
- D:- Check that dirt and dust is removed from operational areas of the pump.
- E:- Inspect the RMK pumps at least every 1000 running hours and renew if any sign of damage is apparent.

#### **A.9 Additional Safety Instructions**

- A) Pumps and ancillary equipment must be drained, cleaned and decontaminated prior to any change of duty.
- B) Where pumps and ancillary equipment contain non-conductive plastic wetted components, dismantling for maintenance must take place in a safe area away from the flammable hazard, or the equipment made safe by purging with nitrogen.
- C) When installing a pump either for the first time or after maintenance, a check must be made to ensure that the earth connection terminal on the pump and any external metalwork is at ground potential.
- D) Where a counter or count and stop device is fitted, it is for indicating the number of cycles run only, and not to use as a means of process flow control or for performing a safety function.
- E) Ensure nozzle forces and bending moments should not exceed the maximum permissible values as specified in technical documents.
- F) Never heat the impeller to remove same as in case of trapped pumping fluid if hazardous may result into explosion.



Enriching Lives

## PART B: INSTRUCTIONS ON INSTALLATION, OPERATION AND MAINTENANCE FOR KIRLOSKAR PUMP TYPE RMK

### 1. GENERAL

1.1 'KIRLOSKAR' make RMK pumps are used for handling various types of CLEAR & CLEAN chemical liquids with leak free transportation. These pumps are manufactured to close tolerance and are of rigid construction, However proper installation, operation and maintenance are equally important to ensure trouble free service. This booklet covers important guidelines and instructions for installation, operation and maintenance. These instructions should be followed carefully for satisfactory performance of the pumping unit. Only mechanical aspects are dealt within this booklet.

#### 1.2 Applications:

RMK pumps are mainly used in process industries like petrochemicals, nuclear, refinery, fertilizer, paper, sugar etc. and power plants. The pump can handle corrosive acids, alkalies, salt solutions, caustics, hydro-carbons, oils, liquefied gases, condensates, viscous liquids etc. Use for application involving entrained gases, fumes & solids is not permitted to avoid dry running of pumps.

#### 1.3 Nomenclature: RMK32/13-1R

RMK – Kirloskar ROMAK Pump

32 - Delivery size in mm

13 - Impeller diameter in cm.

1R - 1 Ring (Pair of Magnet rings)

#### 1.4 This booklet covers instructions for following models

Drive unit 5

5.1	32/13	40/13	50/13	65/13	
5.2	32/16	40/16	50/16	32/16A	50/16A
5.3	32/20	40/20	50/20	32/20A	40/20A

Drive unit 7

7.1	65/16	80/16			
7.2	65/20	80/20	100/20		
7.3	32/26	40/26	50/26	65/26	80/26
7.4	40/32	50/32			

#### 1.5 Nameplate information:

Every pump has the nameplate fitted to bearing housing provided with necessary identification of the pump and its specific hydraulic characteristics.

The nameplate of pump must not be removed. Loss of this plate could make identification impossible. This in turn could affect safety and cause difficulty in obtaining spare parts.





Enriching Lives

Enriching Lives

PUMP TYPE

PUMP NO.

O/A NO. / MISI

TOTAL HEAD  m

DISCHARGE  m<sup>3</sup>/hr

PUMP INPUT  kW

IMPELLER DIA.  mm

SPEED  rpm

MAT. CODE

MFG

SERVICE

RECOMMENDED PRIME MOVER RATING  kW

WARNING: PUMP SHOULD NOT BE RUN BELOW/ABOVE  m TOTAL HEAD.

REGD. USERS -  
KIRLOSKAR BROTHERS LIMITED  
UDYOG BHAVAN, PUNE-411002, (INDIA),  
WORKS- KIRLOSKARVADI.

- 1.6 Pumps when properly installed & given due care in operation & maintenance should operate satisfactorily for a long period.
- 1.7 When the pump is received, sometime before the actual use of pump, it should be inspected & located in dry place. The coupling should be rotated once in a month to prevent pitting of bearing surfaces.
- 1.8 Tightening Torque values for major pressurized fasteners.

Casing  
(58100,58101)

	Size	No.	Size	Torque, Nm
1	32/13	8	M8	18
2	40/13	8	M8	18
3	50/13	8	M8	18
4	65/13	8	M8	18
5	32/16,32/16A	8	M10	35
6	40/16	8	M10	35
7	50/16,50/16A	8	M10	35
8	32/20,32/20A	8	M12	55
9	40/20,40/20A	8	M12	55
10	50/20	8	M12	55
11	65/16	8	M10	35

Casing  
(58100,58101)

	Size	No.	Size	Torque, Nm
12	80/16	8	M10	35
13	65/20	8	M12	55
14	80/20	8	M12	55
15	100/20	8	M12	55
16	32/26	12	M12	55
17	40/26	12	M12	55
18	50/26	12	M12	55
19	65/26	12	M12	55
20	80/26	12	M12	55
21	40/32	12	M12	70
22	50/32	12	M12	70



Enriching Lives

Can (57800)

	Unit	No.	Size	Torque, Nm
1	5.1	6	M8	15
2	5.2,5.3	6	M8	20
3	7.2	8	M8	20
4	7.1,7.3,7.4	8	M10	35

Bearing holder (57400)

	Unit	No.	Size	Torque, Nm
1	5.1	3	M8	12
2	5.2,5.3	3	M8	12
3	7.1,7.2,7.3,7.4	3	M8	12

Impeller Nut with helicoil insert (33000)

	Drive unit	No.	Size	Torque, Nm
1	5	1	M16	70
2	7	1	M18	100

## 1.9 Contact Information

<b>KIRLOSKAR BROTHERS LIMITED</b>		
<b>REGD. OFF:</b> UDYOG BHAVAN, TILAK ROAD, PUNE-41102 (INDIA)	<b>CORPORATE OFFICE: "YAMUNA",</b> SURVEY NO-98/3-7, PUNE MUMBAI HIGHWAY, BANER, PUNE -411 045 (INDIA)	<b>WORKS:</b> KIRLOSKARWADI, 416308 , DIST.:SANGLI (INDIA)
<b>TEL: 091 020- 2440 0770</b> <b>FAX: 091 020- 2427 0156</b>	<b>TEL: 091 020- 2721 4444</b> <b>FAX: 091 020- 2427 0879</b>	<b>TEL: 091 02346- 221 055</b> <b>FAX: 091 02346- 222 311</b>

**Note:** The information in this document may sometimes be of generic nature and applicable to various company products irrespective of its specific application & use. Additional instructions if any shall be specified on individual project drawings & documents furnished to the buyer against specific order. Where a conflict exists between the contents herein and the actual equipment supplied, the user must make an engineering judgment, else contact KBL. Kirloskar Brothers reserves the right to change the construction & design of the products at any time without being obliged to change products already supplied earlier.

## 2. Safety Instructions:



### 2.1: General Information

Before performing any actions detailed within this instruction, the Site Health and Safety instructions shall be read and fully understood. The instructions in this document shall also be read and fully understood.

Whenever the equipment is operated, maintained or used in any way, the procedures detailed within the Health and Safety Dossier (DHS) and any procedures detailed within these instructions shall be followed. The pump supplied by Kirloskar Brothers Limited (KBL) has been designed with safety in mind; where hazards cannot be eliminated, the risk has been minimized by the use of guards and other design features. Some hazards cannot be guarded against and the instructions below **MUST BE COMPLIED WITH** for safe operation. These instructions cannot cover all circumstances. It is the responsibility of the user of the equipment for maintaining safe working practices at all times. The pumps are supplied with stickers for hazard, caution and safety wherever these are applicable.

2.1.1 Within the manual, safety instructions are marked with safety symbols.

Hazard.



This symbol refers to general mechanical aspects of safety.

Hazard.



This symbol refers to electrical safety.



This symbol is used to introduce safety instructions whose non-Observance may lead to damage to the machine and its functions.



This symbol refers to magnetic field safety.



This symbol refers to restrict person with having heart pacemaker to avoid contact with magnetic components while pump is in running condition or while carrying out maintenance work of pump.

2.1.2 KBL products are designed for installation in designated areas, which are to be kept clean and free of obstructions that may restrict safe access to the controls and maintenance access points.

Pump nameplate is fitted to each unit and must not be removed. Loss of this plate could make identification impossible. This in turn could affect safety and cause

difficulty in obtaining spare parts. Should accidental loss or damage occur, contact KBL immediately.

- 2.1.3 Access to the equipment should be restricted to the personnel responsible for installation, operation and maintenance and they must be trained, adequately qualified and supplied with the appropriate tools for their respective tasks.
- 2.1.4 KBL firmly insists that all personnel responsible for installation, operation and maintenance of the equipment must read the manual before any work is done.
- 2.1.5 Ear defenders should be worn where the specified equipment noise level exceeds locally defined safe levels. Safety glasses or goggles should be worn where working with pressurized systems and hazardous substances. Other personal protection equipment must be worn where local rules apply.

**Caution**

- 2.2 *DO NOT* wear loose or frayed clothing or jewellery, which could catch on the controls or becomes trapped in the equipment.
- 2.3 Operation of the equipment for the application other than for which it is supplied can increase the risk from hazards. Please consult KBL before making such change in the application of the equipment.
- 2.4 Improper installation, operation and maintenance of the product supplied by KBL could result in injury or death.

**Caution**

- 2.5 In case of RMK pumps which are handling fluid at high temperature, the operator should avoid touching the pump in running condition. Use safety equipments like hand gloves and safety shoes while operating RMK pumps in such applications.

**2.6: Transport handling and storage instructions:**

**2.6.1: Transport.**

Pumps are dispatched in duly assembled condition. Lubricating oil in the bearing housing is drained prior to dispatch of pump. Pumps are protected against corrosion and packed for transport by normal road, rail and sea carriers.

**2.6.2: Handling**



**Crushing hazard**

When lifting the pump or pump set, use lifting equipment having a safe working load rating suitable for the weight specified. Use suitable slings for lifting any pump not provided with lifting points.

The use of suitable forklift truck and four chain crane sling equipment is recommended but locally approved equipment rating may be used.

Pump should be slung as shown.

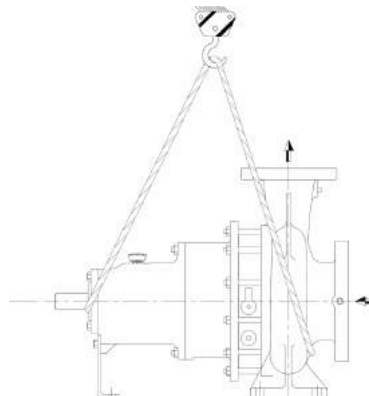

*Lifting of bare shaft pump*

**Caution**

Pump set must be lifted from the lifting holes provided using suitable four chain lifting equipment.

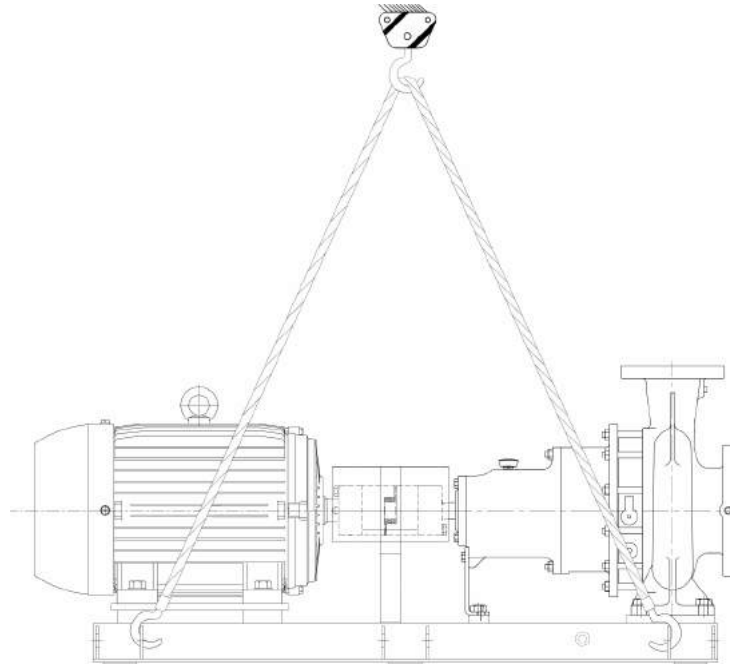

*Lifting of Pumpset*

**2.6.3: Storage.****2.6.3.1: Temporary storage for up to six weeks.**

If the pump unit is not be used immediately it should be stored carefully in a horizontal position, in a sheltered, dry location.

**Caution**

Additional rust preventive should be applied to all unpainted carbon steel or cast iron parts, and should not be removed until final installation.

**2.6.3.2: Long Term Storage.**

If the pump is not to be installed and operated soon after arrival, store it in a clean, dry place, having slow, moderate changes in ambient temperature. Step should be taken to protect the pump from moisture, dust, dirt, and foreign bodies. It is recommended that the following precautions to be taken:

- a) Ensure that the bearings are packed with the recommended grease, to prevent moisture from entering around the shaft.
- b) Ensure that suction and discharge branches of the pump and all other openings are covered with cardboard, wood or masking tape to prevent foreign objects entering the pump.
- d) If the pump is to be stored where there is no protective covering, it is advisable to cover the unit with a tarpaulin or other suitable covering.
- e) The pump shaft should be manually rotated periodically (once in 2 weeks) to prevent pitting of the bearing surfaces due to moisture.



**Shearing Hazard**



Enriching Lives

DO NOT place fingers or hands etc. into the suction or discharge pipe outlets and do NOT touch the impeller, if rotated this may cause severe injury. To prevent ingress of any objects, retain the protection covers or packaging in place until removal is necessary for installation. If the packaging or suction and discharge covers are removed for inspection purposes, replace afterwards to protect the pump and maintain the safety.

Fill the bearing housing with recommended oil to ensure that the shaft and bearings remain rust free.

### 2.6.3.3: Exposed or Extreme Conditions Storage.

For exposed storage or extreme variants in atmospheric or environmental conditions, please refer to KBL for special storage instructions to suit the conditions acceptable.

## 3. Equipment schedule:

### 3.1 INSTALLATION:

3.1.1 For location, preparing foundation, installation, alignment, piping, general maintenance, trouble shooting etc. the instructions given in our publication - 'GENERAL INSTRUCTIONS FOR INSTALLATION, OPERATION AND MAINTENANCE OF KIRLOSKAR CENTRIFUGAL PUMPS' which is also printed along this booklet must be followed very carefully. If the pump is drawing liquid from the vessel under vacuum, then vacuum equalizing connection piping must be made as per instruction given in above publication. The external sealing connection to the pump, if applicable, must be made after installing and before commissioning the pump. Pump on hot service must have final coupling alignment made with the unit at its operating temperature.

#### 3.1.2 Receiving pump

Upon receipt of the pump, a visual check should be made to determine if any damage occurred during transit or handling. The main items to look for are:-

- a) Broken or cracked equipment, including base, motor or pump feet and flanges.
- b) Bent of shaft
- c) Broken motor end bells, bent eyebolts or damaged boxes of motor
- d) Missing parts.
- e) Pump shaft rotates freely.

**Parts or accessories are some times wrapped individually or fastened to the equipment. If any damage or losses have been incurred; promptly notify your KBL representative, KBL Dealer and the transport company who delivered the pump.**

When unloading pump units, lift equally at four or more points from the base.

#### **Caution**

DO NOT LIFT ONLY THE DRIVER OR PUMP.

#### 3.1.3 Preparation

- Before installing the pump, clean the suction and discharge flanges thoroughly.
- Remove the protective coating from the pump shaft.
- If the pump has been in storage and prepared for storage in the manner outlined previously, remove all the grease from the bearings. The bearings should then be flushed with carbon tetrachloride or kerosene and relubricated.

#### 3.1.4 Location

- The pump should be installed as near the liquid source as possible, with the shortest and most direct suction pipe practically.



- The pump should be installed with sufficient accessibility for inspection and maintenance. Ample space and head room should be allowed for the use of an overhead crane or hoist sufficiently strong to lift the unit.
- Make sure there is a suitable power source available for the pump driver. If motor driven, electrical characteristics should be identical to those shown on motor data/name plate.

### 3.1.5 Foundation

- The foundation should be strong enough to reduce vibrations and rigid enough to avoid any twisting or misalignment.
- The foundation should be poured without interruptions to within 20 to 40 mm of the finished height. The top surface of the foundation should be well scored and glued before the concrete sets. This provides a bonding surface for the grout. Foundation bolts should be set in concrete as shown in fig. Allow enough bolt length for grout, shims, lower base plate flange, nuts and washers. The foundation should be allowed to cure for several days before the base plate is shimmed and grouted.

### 3.1.6 Base plate setting

- Use blocks and shims under base for support at foundation bolts and midway between bolts, to position base approximately 25 mm above the concrete foundation with studs extending through hole in the base plate.
- By adding or removing shims under the base, level the pump shaft and flanges. The base plate does not have to be leveled. Draw foundation bolt nuts tight against base plate and observe pump and motor shafts or coupling hubs for alignment.
- Check to make sure the piping can be aligned to pump flanges without placing pipe strain on either flange.
- Grout base plate in completely and allow grout to dry thoroughly before attaching piping to pump (24 hours is sufficient time with approved grouting procedure).

### 3.1.7 Grouting procedure

Grout compensates for uneven foundation, distributes weight of unit and prevents shifting. Use an approved, non-shrinking grout as follows, after setting and leveling unit

- Build strong form around foundation to contain grout.
- Soak top of concrete foundation thoroughly, then remove surface water.
- Base plate should be completely filled with grout and, if necessary, drill vent holes to remove trapped air.
- After grout has thoroughly hardened, check the foundation bolts and tighten if necessary.
- Check the alignment after the foundation bolts are tightened.
- Approximately 14 days after the grout has been poured or when the Grout has thoroughly dried, apply an oil base paint to the exposed edges of the grout to prevent from air and moisture coming in contact with the grout.

### 3.1.8 Suction and Discharge Piping

When installing the pump piping, make sure to observe the following precautions:-

- Piping should always run to the pump. Do not move pump to pipe. This could make final alignment impossible.
- Both suction and discharge piping should be supported independently and close to pump so that no strain is transmitted to the pump when the flange bolts are tightened.

- Use pipe hangers or other supports at necessary intervals to provide support. When expansion joints are used in the piping system, they must be installed beyond the piping supports close to the pump.
- It is advisable to increase the size of both suction and discharge pipes at the pump connection to decrease the loss of head from friction. Suction velocity to be restricted to 1.5 to 2 m/s & Discharge velocity to be restricted to 2.5 to 3 m/s.
- Install piping as straight as possible, avoiding unnecessary bends. Where necessary, use long sweep 90 degree bend to decrease friction losses.
- Make sure that all piping joints are air tight. Provide pipe expansions bellows when hot fluids are to be pumped. Where reducers are used, eccentric reducers are to be fitted in suction lines and straight taper reducers in discharge and vertical lines.
- Misuse of reducers may cause the formation of air pockets in the pipe and thus preventing the correct operation of the pump.
- The suction pipe should be as short & direct as possible. Where suction lift is not very high, it is advisable to use a foot valve. Horizontal suction line must have a gradual rise to the pump.
- The discharge pipe is usually preceded by a non-return valve or check valve and a discharge gate valve. The check valve is to protect the pump from excessive back pressure and reverse rotation of the unit and to prevent back flow into the pump in case of stoppage or failure of the driver. The discharge valve is used in priming, starting and when shutting down the pump.

### 3.2 MOUNTING AND ALIGNMENT

A spacer type flexible coupling is used to connect pump shaft to the driver. By using spacer type of coupling, the complete rotating unit can be removed from the volute without removing pump casing or rotor and without disconnecting piping connections. This also avoids any realignment of pump and motor after re-assembly of rotating unit. However other types of coupling can be supplied against request.

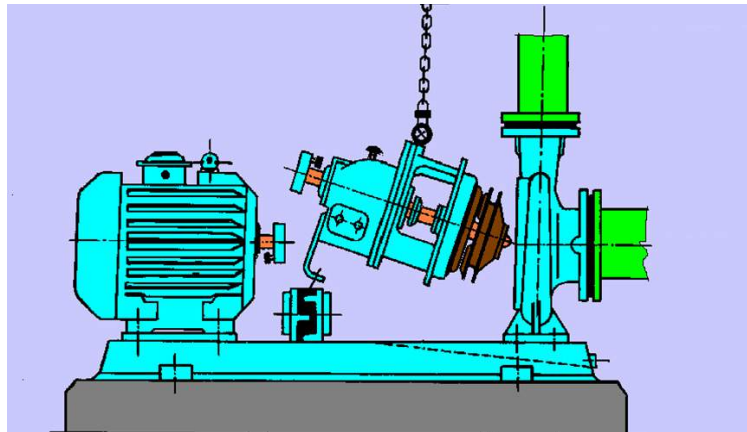

*Back pull out assembly*

#### 3.2.1 ALIGNMENT

The pump driver, if supplied, is correctly aligned on its base plate at the factory. A certain amount of deformation of the base plate is possible during transit and it is therefore essential to check alignment, prior to final grouting.

**A flexible coupling will only compensate for small amount of misalignment and should not be used to compensate for excessive misalignment of the pump and driver shafts.**



**Inaccurate alignment results in vibration and excessive wear on the bearings, sleeve or shaft and wear rings.**

**ALWAYS REMEMBER "A FLEXIBLE COUPLING IS NOT A UNIVERSAL JOINT"**

Correct alignment is essential for the smooth operation of the pump. There are two types of misalignment between the pump shaft and the drive shaft, which are:

1) **Angular misalignment** – shaft with axis concentric, but not parallel.

Maximum allowable misalignment is 1°

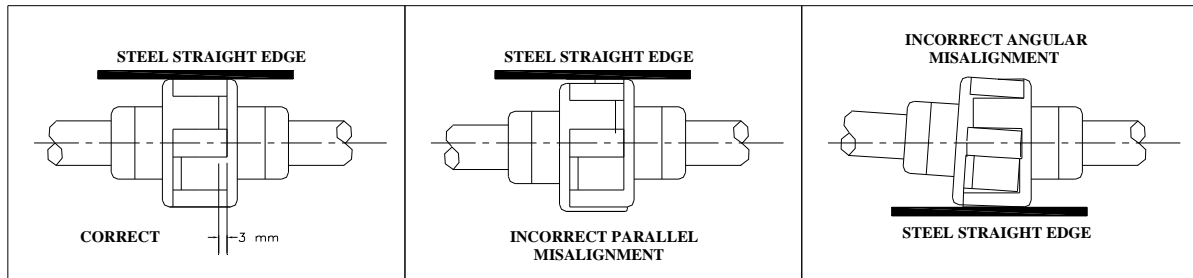

*Checking coupling alignment with straight edge*

2) **Parallel misalignment** – shaft with axis parallel, but not concentric.

Maximum allowable misalignment is 0.2 mm

This misalignment is checked by using a straight edge as shown in figure given above. Coupling alignment can be checked with dial gauge Indicator. Alignment should be performed after the base plate has been properly set and grout has dried thoroughly according to instructions. Final alignment should be made by shimming under driver side only.

Alignment should be made at operating temperatures.

#### FACTORS THAT MAY DISTURB ALIGNMENT

The unit should be periodically checked for alignment. If the unit does not stay in line after being properly installed, the following are possible reasons:

- a) Setting, Seasoning of the foundation.
- b) Pipe strains, distorting or shifting of the machines.
- c) Wear of the bearings.

3.2.1.1 Before commissioning the pump set, please ensure:

- A) The pipe connections are flushed and tightened properly.
- B) Alignment is proper.
- C) Auxiliary piping connections such as lubricating connections etc are made.

Details of lubricating liquid are given in our supply order.

Please refer to Figure given below for plugs and piping connections.

## ROMAK pumps – TAPPING CONNECTION DETAILS / CHART

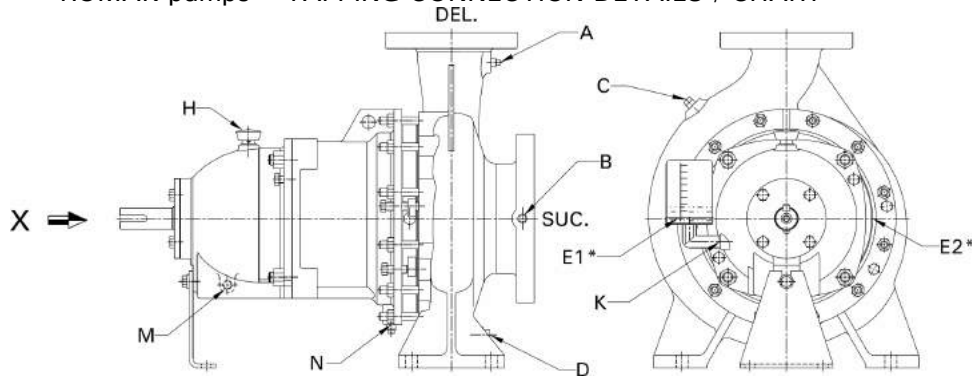

Code	Description	Location of connection when viewed from driving end
A	Gauge connection discharge side.	On Pump discharge flange.
B	Gauge suction side.	On Suction flange right.
C	Casing liquid temperature connection.	On Casing top left.
D	Pump casing drain.	On Pump Casing bottom side towards suction.
E1*	Plain bearing lubrication inlet.	On Casing Cover, top left.
E2*	Plain bearing lubrication Outlet.	On Casing Cover, bottom right.
H	Breather cap.	On Bearing Housing top.
K	Constant level oiler.	On Bearing Housing left.
M	Bearing housing oil drain.	On Bearing Housing left.
N	Can Leakage drain.	On Lantern Bracket Left or at Center

\* This special provision on request /application requirement only and at extra cost.

**Tapping size details for RMK pump:**

SR. NO.	CODE OF PIPE CONN	DESCRIPTION	SIZE OF CONNECTION
1	A	Gauge connection discharge side	1/4"
2	B	Suc. Gauge / Vaccum equilising conn	1/4"
3	C	Flushing/Sealing conn. From pump casing.	1/4"
4	D	Pump casing drain	1/2"
5	E1*	Plain bearing lubrication inlet.	1/4"
6	E2*	Plain bearing lubrication Outlet.	1/4"
7	H	Air breather Cap	20 mm hole
8	K	Constant level oiler	1/4" BSP
9	M	Baring housing oil drain	1/4" BSP
10	N	Can Leakage drain	1/4"

**Notes :**

All connections are NPT except specified.

Location of connections are specified looking from arrow "X".

\* This special provision on request / application requirement only and at extra cost.

**3.2.1.2 CONSTANT LEVEL OILER**

RMK pumps are oil lubricated as standard scope of supply. Pump is provided with constant level oiler.

Fix the constant level oiler and fill the oil. Procedure for fitting the constant level oiler and the method of filling oil is given below.

Constant level oiler has plastic container in Aluminium body as a standard supply. Connection stem is ¼ inch BSP tapped and its capacity is 70 ml approximately. If the constant level oiler is properly fitted and oil is filled as per instructions given, practically no attention is required as far as lubrication of bearing is concerned other than to replenish the visible reserve supply of the oil in the container ref figure given below. (For other make constant level oiler available in market (if supplied) refer respective catalogue / operating manual.)

### 3.2.1.3 METHOD OF FITTING

Screw constant level oiler stem into the tapped hole of the bearing housing reservoir. Before fitting oiler, check the level of the tapped hole with the help of a turned bar with ¼ inch BSP tapping at one end and a spirit level. See figure, if the level is incorrect and oiler tilts downward, oil will not flow from oiler into the reservoir (see fig given below.). Hence it is necessary to check the level before fitting in the constant level oiler.

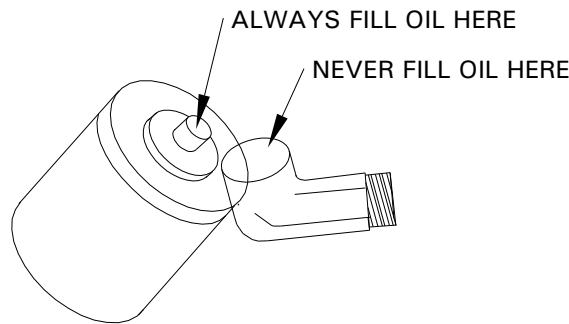
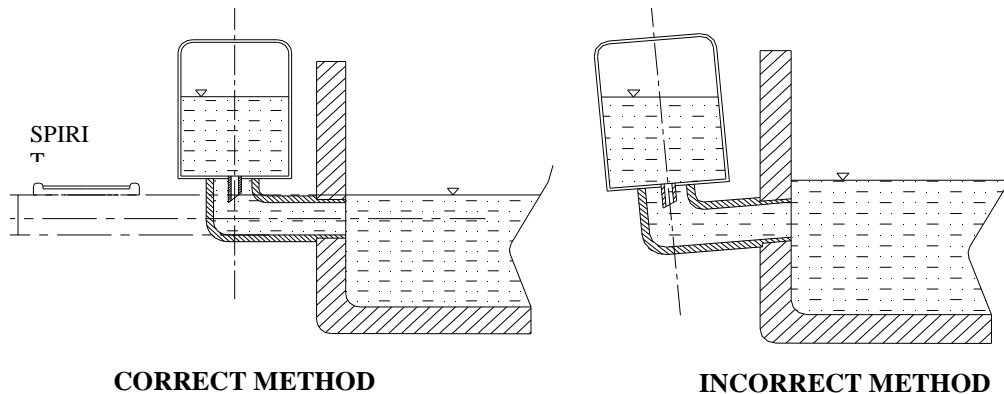

### 3.2.1.4 Method of filling the oil.

Tilt the container and fill it with oil through stem of the oiler. Replace the container and allow oil to flow into reservoir. The oil in the container shall flow into the bearing housing reservoir and shall become empty. Repeat above procedure till the level in the reservoir is equal to the level of which the oiler is adjusted. When the desired level is attained, the oil in the container shall remain steady at a position. Visible level of the oil in the container indicates that bearing housing is filled up to mark.

**Caution**

- 1) In no case oil should be filled directly in to the bearing housing reservoir, through breather cap.



Enriching Lives

- 2) Replenish the visible reserve supply of oil in the container as oil is used up.
- 3) Please ensure that air 'GROOVE' provided on Aluminum body on which plastic container rests is not clogged with dust / fiber oil film etc. this groove allows atmospheric air to enter inside the body, to maintain oil level in bearing housing.

## 4. Operation.

### 4.1 EQUIPMENT DESCRIPTION:

End suction centrifugal pump type RMK is from KBL manufactured process pump series which dimensionally conforms to DIN 24256 / ISO 2858 & technically meeting requirements of ISO5199.

The mechanical assembly comprises a rigid shaft, supported by a pair of bearings, Permanent Magnet assemblies mounted on rotors, in between can with a enclosed impeller mounted on plain bearing assemblies. This is attached to an end suction volute casing fitted with wear rings. The ball bearing housing, magnet assembly, plain bearing assembly and impeller assembly can be withdrawn from the volute for maintenance without disconnection of pipe work.

The discharge branch is positioned vertically upwards while suction branch is horizontal and is at 90° to discharge nozzle. An additional mounting foot is fitted at the outer bearing position for stability.

Refer general cross sectional assembly & Exploded view of pump provided at end of this leaflet to get better idea of pump design.

The complete assembly is of rigid construction, being intended for mounting on suitable base plate with electric motor / internal combustion engine. A suitable coupling is provided to transmit the rotational drive between pump and motor. A spacer coupling most suitable to use, because it allows the removal of the pump rotating assembly without disconnecting suction pipe, discharge pipe and motor.

### 4.2 EQUIPMENT OPERATION.

#### Caution

Never run ROMAK pumps in dry condition. Internal plain bearings will fail immediately if pumps are run in dry condition.

#### 4.2.1 Before starting the pump check the following:

- 1) The pump rotates freely by hand.
- 2) The level of the oil in the constant level oiler is up to the mark.
- 3) The external lubricating liquid connections if applicable are properly tightened and adjusted.
- 4) The direction of rotation of driver. It should correspond to the direction of rotation of pump. Do not run dry pump in this case.
- 5) The pump casing and the suction pipeline is fully primed with the liquid.
- 6) Valve on delivery side is closed.
- 7) The cock for pressure gauge connection is closed.

#### 4.2.2 Starting the pump

- 1) In case of external lubricating liquid for plain bearing, start the liquid supply before starting the pump. Do not start the pump without liquid inside the bearing area.
- 2) Start the pump. Let the prime mover pickup its full speed.
- 3) Open the valve on delivery line gradually.
- 4) Regulate the required flow by adjusting the delivery valve.

- 5) Open the cock for pressure gauge connection.
- 6) When motor is running but pump is not giving discharge that indicates magnet coupling is decoupled. Stop the motor immediately. Otherwise it will result into heating of magnet, in turn liquid & can. Check for cause of same by taking care of Starting torque for Pump & Motor.

#### 4.2.3 During running the pump check the following things and regulate if needed -

- 1) The pump is running smooth.
- 2) The flow of external lubricating liquid for plain bearing is uninterrupted. If necessary, provide sight glass in the piping.
- 3) The bearings are not getting abnormally hot.
- 4) Head and capacity developed by the pump is as specified.
- 5) Power consumption is within limit.
- 6) Ensure that there is no noise generated because of mechanical friction in the pump.
- 7) Stop the pump immediately, if any, defects are detected. Do not start the pump unless the defects are rectified. If it is not possible to rectify the defects then report immediately to the supplier or authorized dealer or nearest KBL office.

#### 4.2.4 During stopping the pump

- 1) Close the valve on the delivery line. Ensure that pump will not run for more than few seconds in this condition.
- 2) Stop the motor.
- 3) Close the external lubricating liquid for plain bearing connections.
- 4) If the pump is not required to be operated for a long time, drain the pump casing completely. If the pump is required to be stored for a long time, the bearing housing should be dried internally with hot air and should be flushed with moisture free protective such as light oil or kerosene.
- 5) If any external lubricating liquid for plain bearing arrangements are provided then it must be drained and dried.

## 5. MAINTENANCE MANUAL.

### 5.1 MAINTENANCE EHS INSTRUCTIONS

Following hazards may arise during maintenance work.



#### Fluid Pressure Jet Hazards

Check and ensure that the pump operates at below the maximum Working Pressure specified.



#### Hazardous materials:

Wear a suitable mask or respirator when working with chemical material handling.



#### Hazardous Gases, Mists, Sprays and Leaks.

Be aware of the hazards relating to the pumped fluid, especially the danger from inhalation from noxious and toxic gases, skin and eye contact or penetration. Obtain and understand the hazardous substance data sheets relating to the pumped fluid and note the recommended emergency and first aid procedures.

Before attempting any maintenance on a pump, particularly if it has been handling any form of hazardous liquid; ensure that the unit is safe to work on. The pump must be flushed thoroughly with suitable cleanser to purge away any of the product left in the pump components. The plant operator should carry this out and a certificate of cleanliness obtained before starting work. To avoid any risk to health it is also advisable to wear protective clothing as recommended by the site safety officer, especially when removing old packing that may be contaminated.



#### Electric shock and accidental starting hazard:

equipment before any maintenance work is done. Switch off the mains supply, remove fuses, apply lockouts where applicable and affix suitable isolation warning signs to prevent inadvertent re-connection.

In order to avoid the possibility of maintenance personnel inhaling dangerous fumes or vapors, it is recommended that maintenance work be carried out away from the pump location by removal of the rotating unit assembly to a suitable maintenance area.

## 5.2 GENERAL MAINTENANCE DOCUMENTS:

### 1) Maintenance documents:

- i) Pump Sectional assembly drawing with part list
- ii) Pump Outline dimension drawing
  
- iii) Foundation plan drawing
- iv) Pump datasheet

### 2) Specific maintenance data:

#### 5.2.1: Overhauling:



Use Non-Magnetic toolings for dismantling & re-assembly as far as possible to avoid damage to the components and personal injuries. In case of tooling which are attracted towards magnets keep at safe distance after use. Assembly area should be clean so that surrounding magnetic particles / materials will not get attract to the magnets. Keep Electronic, electrical, mechanical instruments, equipments at a distance to avoid attraction & failure because of magnetic fields. Person with having heart pacemaker prohibited or advised to maintain safe distance from pump.

**Procedure for dismantling and re-assembly**

While dismantling and re-assembling, the cross-sectional assembly drawing and specification part list should be referred.

**5.2.1.1 Dismantling:**

Follow the following steps to dismantle the pump.

- 5.2.1.1.1 Isolate power supply to motor.
- 5.2.1.1.2 Shut off the valves controlling flow to and from the pump.
- 5.2.1.1.3 Drain the liquid from pump by removing the drain plug (60100), or open the pump casing drain cock.
- 5.2.1.1.4 Remove all auxiliary tubing and piping, if applicable.
- 5.2.1.1.5 Drain the lubricating oil from the bearing housing (24000) and remove constant level oiler (44300).
- 5.2.1.1.6 We recommend matching the punch mark of the coupling halves.
- 5.2.1.1.7 In case of the pumps with spacer type flexible couplings, disconnect coupling (pump half and motor half) from the coupling spacer and remove coupling spacer. In case of ordinary flexible couplings, remove the motor from the base.

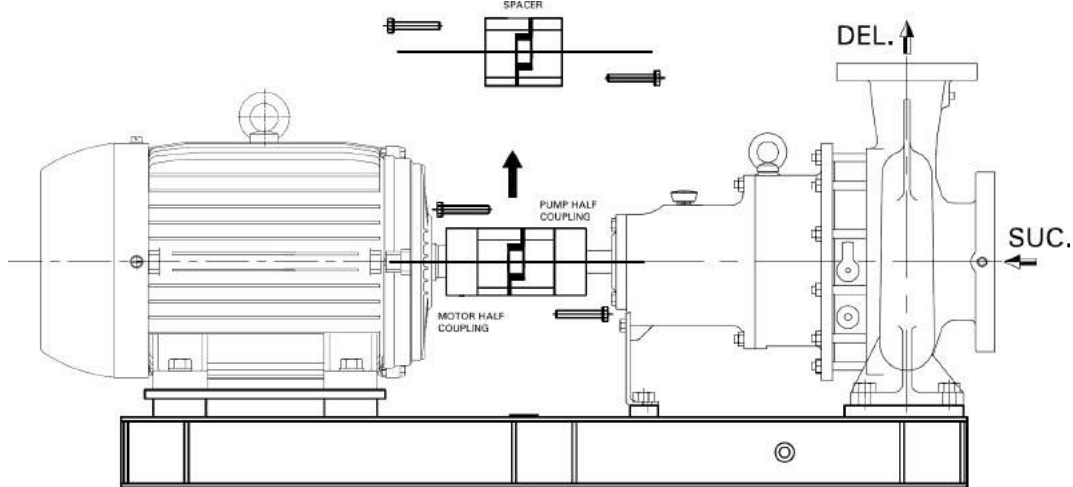

*Removal of coupling*

- 5.2.1.1.8 Remove pump half coupling after unscrewing grub screw.

**Caution**

Coupling half should be removed with the help of suitable extraction device. To avoid damage to the bearings, coupling half should not be knocked out of shaft.

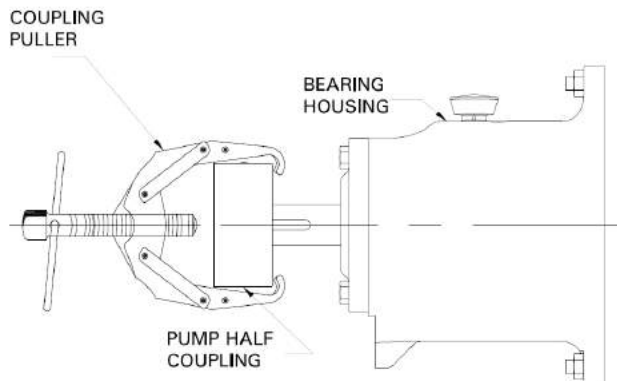

*Removing coupling half from driving end*

- 5.2.1.1.9 Take out coupling key (32102).

- 5.2.1.1.10 Remove the support foot (25100) hold down bolts.
- 5.2.1.1.11 Remove back pull out assembly (use lifting eye bolt provided for higher weight pump models).
- 5.2.1.1.12 In case of casing cover sandwiched between casing and lantern bracket, remove the hexagonal nuts from casing stud holding the lantern bracket (24800) to pump casing (10500).
- 5.2.1.1.13 In case of casing cover is tightened directly to casing (i.e. casing cover is not sandwiched between casing and lantern bracket), remove the hexagonal nuts from casing stud holding the casing cover (22000) to pump casing (10500).
- 5.2.1.1.14 Screw the release bolts provided in casing cover. Turn bolts evenly through a quarter turn at both sides.
- 5.2.1.1.15 Slightly pull out the driving unit till impeller (15100) clears the pump casing (10500).
- 5.2.1.1.16 Place this rotating unit on a table or clean and dry place for further dismantling.
- 5.2.1.1.17 Remove casing gasket (51101).



- 5.2.1.1.18 Remove nuts holding Lantern Bracket (24800) and Bearing Housing (24000). Remove Bearing Housing assembly along with Drive rotor by pulling out from Lantern Bracket. (Here use Puller to overcome magnet force. Make use tap provided on pump shaft (18000) to pull out bearing housing assembly for unit 7 pump models)
- 5.2.1.1.19 Remove Lantern bracket from casing cover with the help of release screws.
- 5.2.1.1.20 Remove Can Cover (23100) and Can (17900) from Casing Cover
- 5.2.1.1.21 Unscrew the impeller nut (33000 / 33001). Remove the gasket between impeller and impeller nut (68201).
- 5.2.1.1.22 Take out the impeller (15100) from impeller shaft (18600). Remove the washer (84901) between impeller and impeller shaft.



- 5.2.1.1.23 Carefully remove Thrust bearing carrier assembly of impeller side and from opposite side take out Impeller shaft along with Impeller rotor assembly, inner bearing sleeve assembly and Thrust bearing carrier assembly. Separate out Impeller rotor, Thrust bearing carrier of Impeller rotor side and impeller shaft.
- 5.2.1.1.24 Remove Outer bearing sleeve assembly along with bearing holder which is screwed to casing cover.
- 5.2.1.1.25 Remove keys of Impeller shaft. This completes dismantling of Wet end inner impeller magnet assembly.



- 5.2.1.1.26 Now from dry end, take out Drive rotor (16906) by removing circlip provided on pump shaft (18000).





Enriching Lives

5.2.1.1.27 Remove bearing cover (along with oil seal) of Driving end side. (For unit 7 remove bearing cover from Non driving end side also)

5.2.1.1.28 Remove Pump shaft along with bearings from bearing housing by pressing towards coupling side.

5.2.1.1.29 **Caution** Take out the bearings (26000) from pump shaft with the help of puller or pressing shaft on arbour press with uniform pressure in case of only if bearings are damaged and to be replaced.

5.2.1.1.30 Oil seals in the DE & NDE bearing cover (50001/50002) and in the bearing housing should be removed if the oil seal lips are worn out or spring has lost tension.

5.2.1.1.31 Casing ring suction side (19000), casing ring delivery side (19100) are to be removed only, if they are worn out and need replacement.

5.2.1.2 **RE-ASSEMBLY :**  
This procedure covers re-assembly of pump after complete dismantling of the pump. Before re-assembly, all the parts should be thoroughly cleaned in kerosene, petrol or benzene to remove the dust, rust etc. After cleaning the necessary parts should be replaced. Refer Chart of tightening torques at respective location nut, screws.

5.2.1.2.1 In case bearings are removed, mount the new ball bearings (26000) at Driving end & Non driving end



a) Use arbour press while fitting the bearings. However it is recommended that bearings should be heated in oil bath at temperature 70 to 80°C and then fitted. (If hot oil bath is not available then ARBOUR PRESS must be used).

**Use gloves while fitting bearings from hot oil bath.**

b) Slide inboard bearing on shaft by hand; make sure that it is square with shaft. Press evenly the inner race of the bearing until bearing is seated firmly against the shaft shoulder.

c) Don't use hammer to fit the bearings. Do not damage the shaft surface especially where it is in contact with oil seal.

5.2.1.2.2 Fit Oil seal into the bearing housing in case of unit 5. (In case of replacement if they are removed / damaged.)

5.2.1.2.3 Insert shaft (18000) along with bearings in to the bearing housing from driving end.

5.2.1.2.4 Replace oil seals in bearing cover (27000) if they are removed / damaged.

5.2.1.2.5 Put gasket (51400) of bearing cover and tighten bearing cover with the aid of hexagonal headed screws / Cap screws.

5.2.1.2.6 Place gasket (51301) on bearing housing (24000). Lubricate gasket with grease.



5.2.1.2.7 Put Drive rotor (169D1) fitted with magnet assembly on to the shaft and insert external circlip (48600).



Enriching Lives

5.2.1.2.8

This completes dry end assembly.

Take Impeller shaft (18600). Insert keys on impeller shaft.



5.2.1.2.9

Slide impeller rotor assembly on to the shaft and rest on step provided of shaft.

5.2.1.2.10

Slide Thrust bearing carrier assembly (247S1) of impeller rotor side & Inner bearing sleeve assembly (311S1) on to the shaft. Make sure sleeve is resting on face of Impeller rotor hub. There is no gap. Also sleeve is not protruding outside from second step of shaft.

5.2.1.2.11

Take casing cover (22000). Insert outer bearing sleeve assembly (311S2) and tighten it with the help of bearing holder (25400). Make use of locating grub screw to make sure lubricating grooves of bearings are always in horizontal position.

5.2.1.2.12

Insert impeller shaft assembly made in step 5.2.1.2.11 into the casing cover assembly made in step 5.2.1.2.12 from bearing housing side. Slide thrust bearing carrier assembly (247S1) of impeller side on to this assembly.

5.2.1.2.13

Insert washer (84901).

5.2.1.2.14

Push impeller (15100) on shaft till it touches the washer.

5.2.1.2.15

Fix the impeller nut (33000) along with helicoil insert (47900) and gradually tighten it.

5.2.1.2.16

Place Can (17900) on casing cover putting in between gasket (51201) & fix Can cover (23100) on can the help of grub screws.

5.2.1.2.17

Rotate impeller and check there is no any abnormal sound present.

5.2.1.2.18

Take pump casing (10500) and put gasket (51101). Lubricate gasket with grease.

5.2.1.2.19

Insert completed casing cover assembly into the casing guide.

5.2.1.2.20

Mount lantern bracket (24800) on the casing cover guide putting in-between gasket (51302). Tighten all the nuts on casing studs firmly and evenly.

This will complete wet end assembly.

### Caution

5.2.1.2.21

Now slide dry end assembly on to the wet end assembly. Please note, because of magnetic forces between inner and outer magnets, there will be sudden jerk hence make use of crane to slide smoothly drive end assembly on wet end assembly. Tighten all the nuts on lantern bracket studs firmly and evenly.

5.2.1.2.19

Fit constant level oiler (44300), Breather cap (44400) & support foot (25100) to bearing housing.

5.2.1.2.20

Rotate shaft by hand and ensure free rotation.

5.2.1.2.21

Fit pump half coupling.

5.2.1.2.22

Fit all applicable accessories such as sealing and flushing liquid, casing drain piping etc.

5.2.1.2.23

Fit coupling spacer between pump half and motor half coupling in case of spacer type flexible couplings.

5.2.1.2.24

Mount motor on the base in case of standard flexible coupling and align the unit.

5.2.1.2.25

Fit coupling guard.



## SPECIAL IMPORTANT INSTRUCTIONS

- 1) The instructions given in this book are of general nature. This manual is to be read in contest with C/S (cross-sectional) drawing supplied against order.
  - 2) This drawing should be referred while commissioning of pumps and carrying out any maintenance work.
  - 3) Impeller nut (33000) together with helicoil mid grip insert should be treated as one part only. Please do not try to take out helicoil mid grip insert out of impeller nut. If helicoil mid grip insert is damaged, please replace impeller nut by new one. Spare impeller nut is always supplied with helicoil mid grip insert duly fitted in it.
  - 4) Inner bearing sleeve assembly, Outer bearing sleeve assembly, Thrust bearing sleeve assembly, Drive rotor assembly, Impeller rotor assembly sketches are attached at end of this manual. These should be treated as separate subassemblies. In case of found damage of any of above, same should be replaced as individual subassembly only.
- **Maintenance tools required:**  
Make use of Non-Magnetic tools for dismantling and reassembling to avoid injury as far as possible. Keep at safe distance all tooling after use. Toolbox containing a general set of tools such as different size ring spanners, torque wrenches, open ended spanners, light ball peen hammer, wooden mallet, various sizes Allen keys etc serves the purpose. It is important to ensure that the suitable lifting equipment is available and that the work is carried out in clean area.

### 5.3 PREVENTIVE MAINTENANCE:

Preventive maintenance schedule is the periodical checks and precautions by which possibilities of failures and breakdowns are minimized.

#### 5.3.1 Daily checks:

- 5.3.1.1 Hourly record of suction and delivery pressure, discharge quantity input to the pump driver should be maintained.
- 5.3.1.2 Bearing temperature, oil level, lantern bracket leakage, sealing / lubricating water inlet and outlet temperature if applicable should be checked. This gives an idea of mechanical performance of the pump.
- 5.3.1.3 Noise and vibrations are the first signs of impending troubles like cavitations, air lock, bearing failure, choking of impeller or casing and such other operating troubles. The pump performance should therefore be checked for noise and vibrations.

#### 5.3.2 Periodical checks:

- 5.3.2.1 The temperature of the bearing should be measured by thermometer. Safe maximum working temperature of the bearing is 80°C.
- 5.3.2.2 The lubricants of the bearing should be checked. The lubricant might get contaminated with foreign material or get blackened due to overheating. In such cases, bearings should be flushed and charged with fresh lubricants.
- 5.3.2.3 Check for the Lantern Bracket leakage.
- 5.3.2.4 The alignment of the pump unit should be checked. Due to operational vibrations, atmospheric temperature or stress induced by the weight of the piping, the alignment may get disturbed.
- 5.3.2.5 Sufficient quantity of suitable type of lubricant should be ready for daily and emergency use.



5.3.2.6 Calibrate the measuring instrument.

### 5.3.3 Annual checks:

- 5.3.3.1 The pump should be overhauled completely to check the clearance and to replace worn-out parts. Clearance between impeller wear rings and casing wear rings are very important. The bearings should be cleaned thoroughly and lubricated.
- 5.3.3.2 The effects of liquid handled on pump components should be checked. If abnormal corrosion, erosion is observed, the component should be replaced with that of suitable material.
- 5.3.3.3 The auxiliary pipelines and functioning of the auxiliary system should be checked. The main pipe also should be checked for scaling, leakage etc.
- 5.3.3.4 The measuring instruments, gauges etc should be recalibrated.
- 5.3.3.5 Full running test may be carried out to check whether there is any fault in the performance, in comparison with original performance.
- 5.3.3.6 Piping supports should be checked so that the pipes do not induce unwanted stresses on the pump.

### 5.3.4: SSiC Bearing assemblies in pump:

SSiC bearing assemblies are precision product having been subjected to quality control throughout all stages of manufacture. The bearings are designed to accommodate reasonable tolerances in the equipment, however in order to obtain the maximum life with trouble free performance, the equipment should be adequately maintained.

When bearings are functioning satisfactorily, the preventive maintenance is not advocated. While fitting the bearing subassemblies in the pump initially by KBL, due care is taken for its proper fitment.

Like other parts in the equipment the bearings are subject to wear at the mating faces of the rotating and stationary bushes. The rate of wear will differ with the operating conditions and various other factors such as lubricating property of the liquid pumped, the presence of impurities in liquid and other operating conditions. In view of this no firm recommendations can be given for renewal of individual subassemblies / complete subassemblies.

**External Lubrication / flushing:** The bearings are not designed to run in dry condition. Hence in case of external lubrication do not run the pumps without first starting external lubrication / flushing into the casing cover. Please refer pump cross section drawing and general arrangement drawing for flushing connection details, pressure and temperature details.

## 5.4 CORRECTIVE MAINTENANCE

### PUMP TROUBLE

When investigating trouble with Kirloskar pumps, always remember that pumps have been tested at the factory and are mechanically correct when sent out. Discounting the possibility of damage during transit, most of the trouble in the field is due to faulty installation. Investigation shows that the majority of troubles with centrifugal pumps result from faulty conditions on the suction side.

### BREAK DOWN-CAUSE-CHECK POINTS

In case of breakdown we recommend the location of the fault by referring the table for 'Break Down Check Points' given at the end of this manual.



## 6.0 TECHNICAL DATA:

### 6.1 Direction of rotation:

The direction of rotation is clockwise when viewed from driving end.

### 6.2 Specification of oil seal, quantity of oil, Bearing:

Description	Driving Unit no.	Driving Unit no.
	No 5	No 7
Oil seal DS	30DX42DX7T	35DX47DX7T
Oil seal PS	30DX42DX7T	35DX47DX7T
Quantity of oil in bearing housing (approximate)	0.5 Liter	0.7 Liter
Driving End	SKF-6306 (1 No.)	SKF-6307(1 No.)
Non Driving End	SKF-6306(1 No.)	SKF-6307(1 No.)

### 6.3 Bearings:

- Bearings of SKF make or equivalent and with C3 clearance are used. Bearings are oil lubricated. Oil level in the bearing housing should be maintained with the help of constant level oiler. Constant level oiler is a standard scope of supply.
- Maximum allowable temperature of bearings: 80°C
- In case of new bearings, renew the oil after about 200 hours for first 4 times and then about once a year, if the bearing temperature is always below 50°C and there is only small risk of contamination. If the bearing temperature is upto 80°C and if there is danger of contamination, the oil should be renewed about every six months.

### 6.4 Lubrication:

The oil used should be highly refined straight mineral product of high demulsibility, free from running and acid forming tendencies. Detergent oil may cause foaming and emulsion difficulties, hence should not be used. The oil should be filled in with the help of constant level oiler. For fitting and operating instructions, please refer instructions mentioned in this manual. The lubrication oil should confirm to the following grades of oil available in market.

Recommended oil grade for 10-50 degC ambient temperature is ISO VG68.

### 6.5 SSiC Bearings: -

The SSiC bearing arrangements are suitable for suction pressure less than 5 kg/cm<sup>2</sup>. For applications involving suction pressure above 5 kg/cm<sup>2</sup>, please refer to RO/Mktg. In case of external lubrication of SSiC bearings, for Quantity, temperature & pressure of external lubricating water please contact to RO/Mktg.

6.6 **Nozzle loads:-** Pump can be subjected to nozzle load according to ISO5199.

6.7 **Temperature:** Pumps are designed to handle temperature range from -50°C upto 180°C

### 6.8 Interchangeability:

Parts standardization is optimized utilizing interchangeable components to cover a very wide performance. This unique feature enables the customer to have a very low spare parts inventory even though he may have many sizes of these pumps. Refer Diagram.



Enriching Lives

BALL BEARING HOUSING  
DRIVE SHAFT  
IMPELLER SHAFT

OUTER MAGNET ROTOR ASSEMBLY  
INNER MAGNET ROTOR ASSEMBLY  
LANTERN BRACKET

CAN COVER  
CAN  
SIC BEARING ASSEMBLY

CASING COVER  
IMPELLER  
PUMP CASING

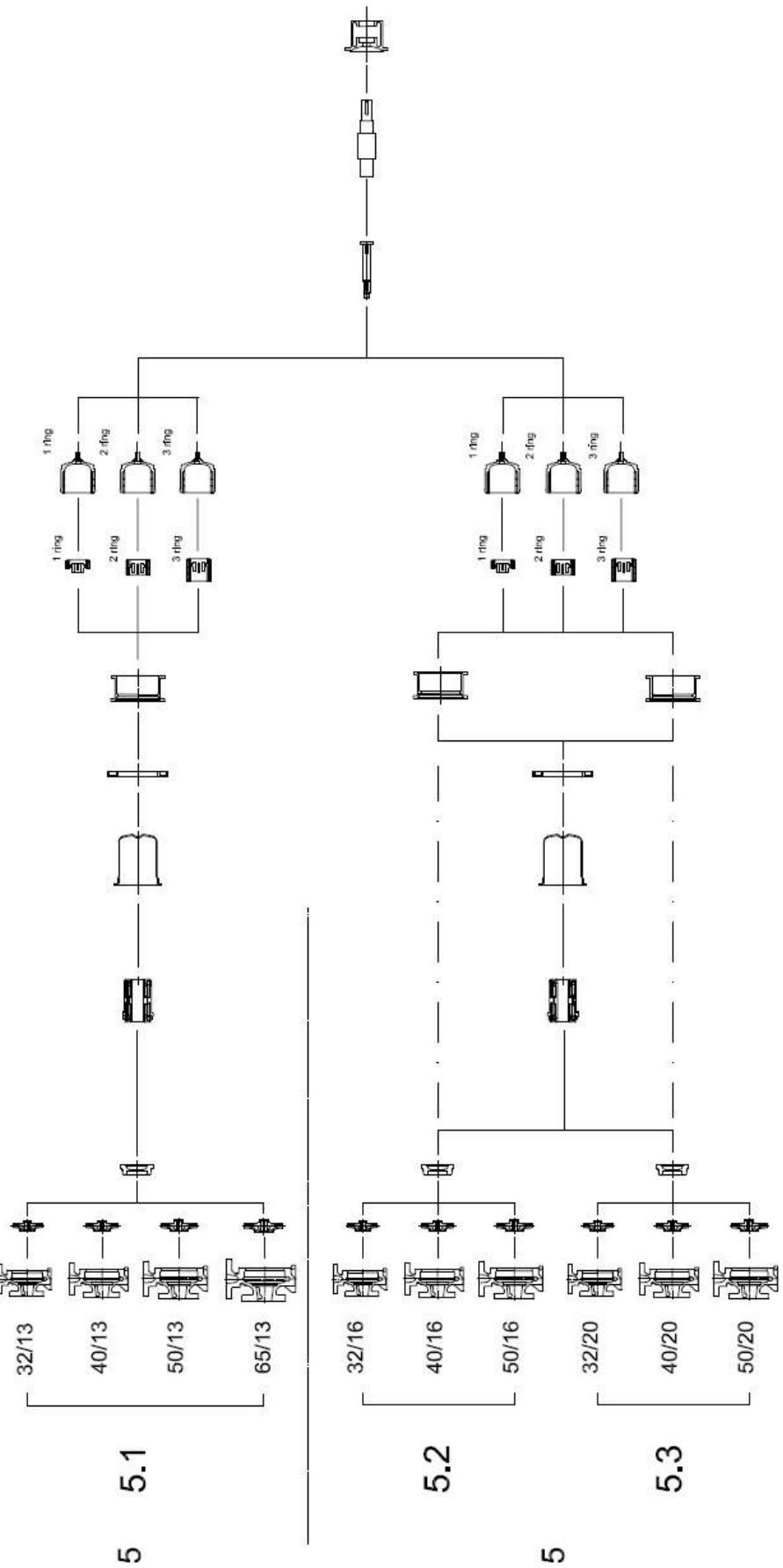

5 5.1

5 5.2

5 5.3



Enriching Lives

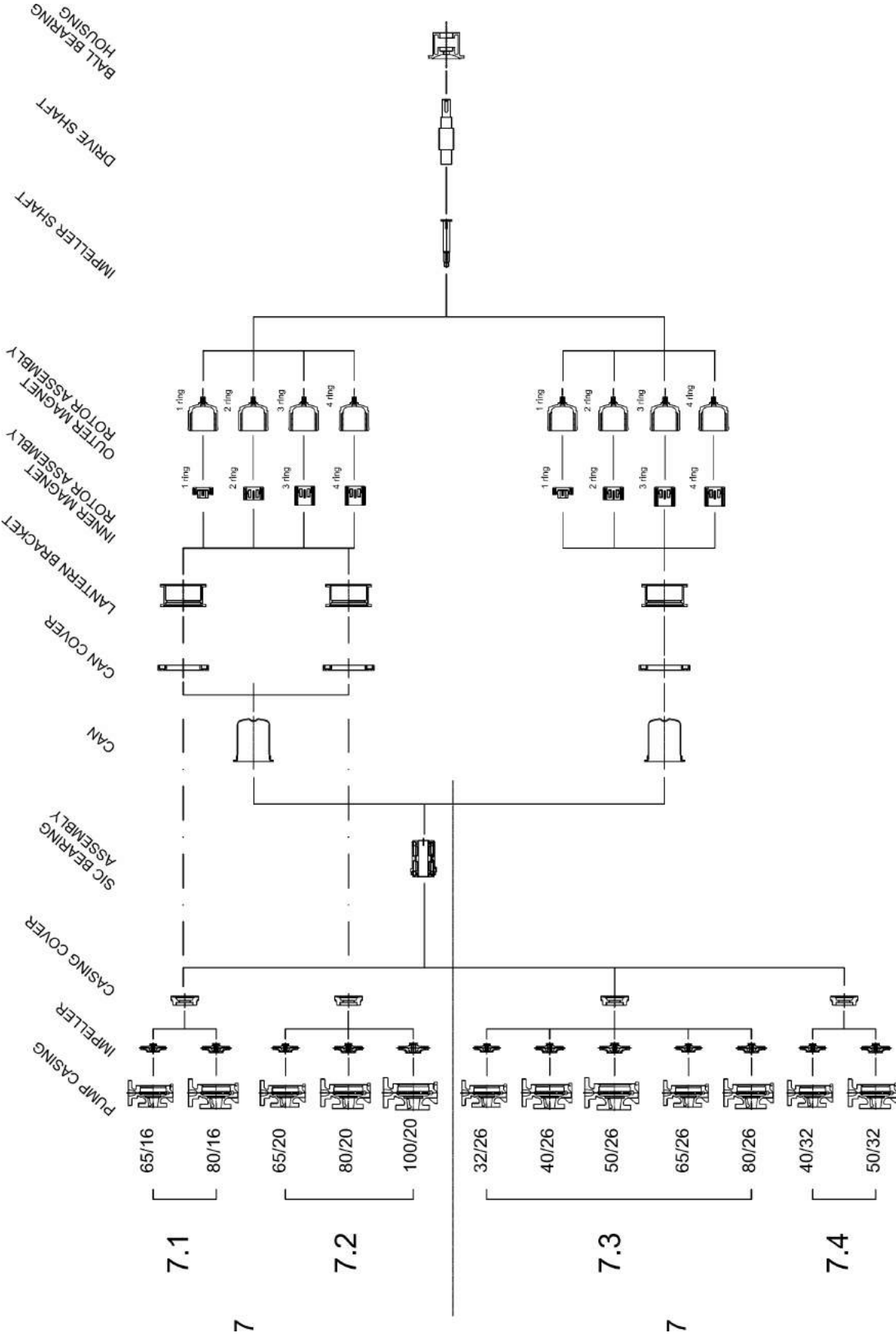



Enriching Lives

## 6.7 PART NUMBER AND DESCRIPTION

PART NO.	PART DESCRIPTION
10500	PUMP CASING (FOOT MOUNTED)
15100*	IMPELLER
169R1	IMPELLER ROTOR 1 RING SUBASSEMBLY
169R2	IMPELLER ROTOR 2 RING SUBASSEMBLY
169R3	IMPELLER ROTOR 3 RING SUBASSEMBLY
169R4	IMPELLER ROTOR 4 RING SUBASSEMBLY
169D1	DRIVE ROTOR 1 RING SUBASSEMBLY
169D2	DRIVE ROTOR 2 RING SUBASSEMBLY
169D3	DRIVE ROTOR 3 RING SUBASSEMBLY
169D4	DRIVE ROTOR 4 RING SUBASSEMBLY
17900	CAN
18000*	PUMP SHAFT
18600*	IMPELLER SHAFT
19000*	CASING RING (SUCTION SIDE)
19100*	CASING RING (DELIVERY SIDE)
19200*	IMPELLER RING (SUCTION SIDE)
19300*	IMPELLER RING (DELIVERY SIDE)
22000	CASING COVER
23100	CAN COVER
24000	BEARING HOUSING
247S1*	THRUST BEARING SUBASSEMBLY
24800	LANTERN BRACKET
25100	SUPPORT FOOT
25400	BEARING HOLDER
26000	DEEP GROOVE BALL BEARING (DE & NDE)
27000	BEARING COVER (DE & NDE)
311S1*	INNER BEARING SUBASSEMBLY
311S2*	OUTER BEARING SUBASSEMBLY
32001	KEY FOR IMPELLER
32002	KEY FOR PUMP ROTOR
32101	KEY FOR DRIVE ROTOR
32102	KEY FOR COUPLING
33000*	IMPELLER NUT
44300	CONSTANT LEVEL OILER
44400	OIL BREATHER
47900*	HELICOIL INSERT
48600*	EXTERNAL CIRCLIP FOR DRIVE ROTOR
49000	FLANGE FOR CASING DRAIN
50002*	OIL SEAL





Enriching Lives

PART NO.	PART DESCRIPTION
51101*	GASKET FOR CSG & CSG COVER (PTFE)
51201*	GASKET FOR CASING COVER & CAN
51301*	GASKET FOR LANTERN BRACKET & BEARING HOUSING
51302*	GASKET FOR CASING COVER & LANTERN BRACKET
51400*	GASKET FOR DE BEARING COVER
53300	PIPE NIPPLE
54200	ELBOW
55000	GATE VALVE
67000	DUTY NAME PLATE
68201*	GASKET BETWEEN IMPELLER & IMPELLER NUT (PTFE)
84901	WASHER FOR THRUST BEARING
57400	CAP SCREW FOR BEARING HOLDER
57800	CAP SCREW FOR CAN HOLDING
58100	HEX NUTS FOR CASING STUDS & LANTERN BRACKET
58101	HEX NUTS FOR CASING STUDS & CASING COVER
58201	HEX NUTS FOR STUDS RECEIV.LANT.BKT.& CSG.COVER
58600	HEX NUTS FOR STUDS RECEIV.BRG.HSG.& LANT.BKT.
59001	STUDS ON CASING TO RECEIV.CSG.COVER & LANT.BKT.
59100	STUDS ON PUMP CASING TO RECEIVE CASING COVER
59101	STUDS ON CASING COVER TO RECEIVE LANT.BKT.
59300	STUDS ON LANT.BRACKET TO RECEIVE BRG.HOUSING
63001	HEX RELEASE SCREW FOR CASING COVER
63002	HEX RELEASE SCREW FOR LANTERN BRACKET ON BRG HSG
63003	HEX RELEASE SCREW FOR CASING
63101	HEX SCREW FOR DE BEARING COVER
63200	HEX SCREW FOR SUPPORT FOOT

\* Recommended commissioning spares.

**ROMAK Subassemblies drawings:**

**a. Casing drain piping:**

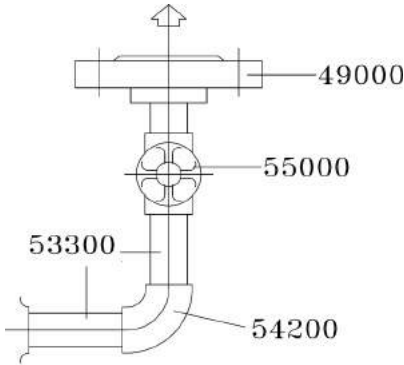

PLAN OF DRAIN PIPING  
(CASING DRAIN)

**b. Drive rotor assembly:**

Drive rotor with Outer magnet glued assembly.

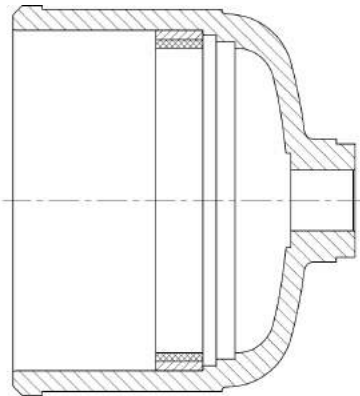

169D1 - DRIVE ROTOR  
ASSEMBLY with 1 MAGNET RING

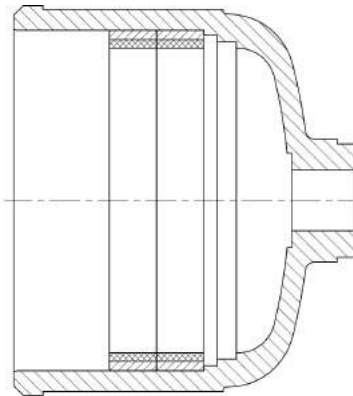

169D2 - DRIVE ROTOR  
ASSEMBLY with 2 MAGNET RING

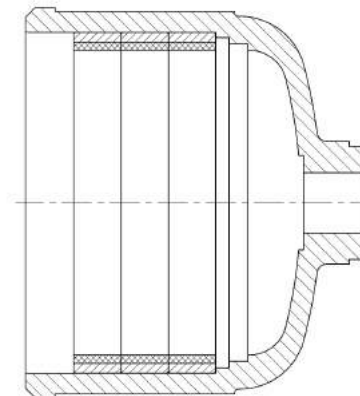

169D3 - DRIVE ROTOR  
ASSEMBLY with 3 MAGNET RING

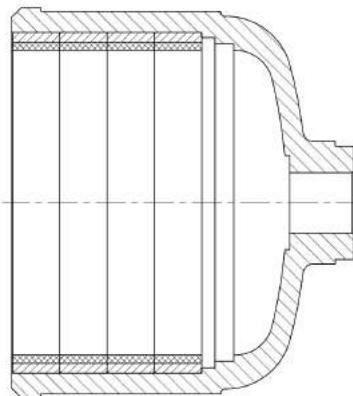

169D4 - DRIVE ROTOR  
ASSEMBLY with 4 MAGNET RING

**c. Impeller Rotor assembly: Impeller rotor with inner magnets.**

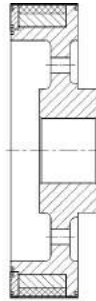

169R1 - IMPELLER ROTOR ASSEMBLY with 1 MAGNET RING



169R2 - IMPELLER ROTOR ASSEMBLY with 2 MAGNET RING

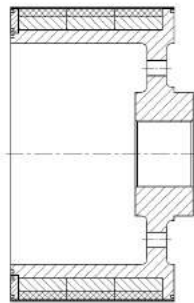

169R3 - IMPELLER ROTOR ASSEMBLY with 3 MAGNET RING

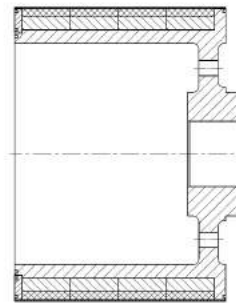

169R4 - IMPELLER ROTOR ASSEMBLY with 4 MAGNET RING

**d. Inner bearing sleeve assembly (311S1)**

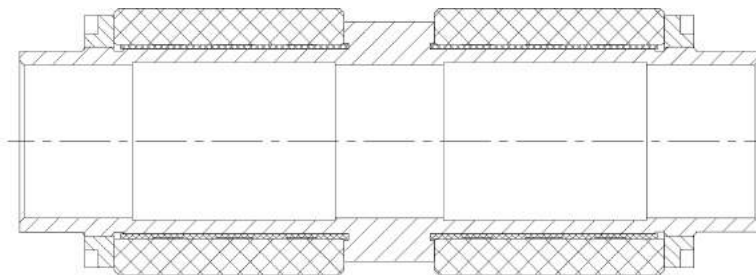

**e. Outer bearing assembly (311S2)**

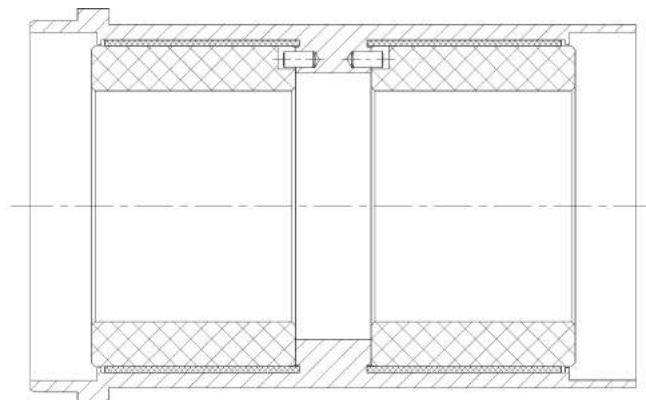

**f. Thrust bearing carrier assembly (247S1)**



**g. Typical general Wet end pump assembly**

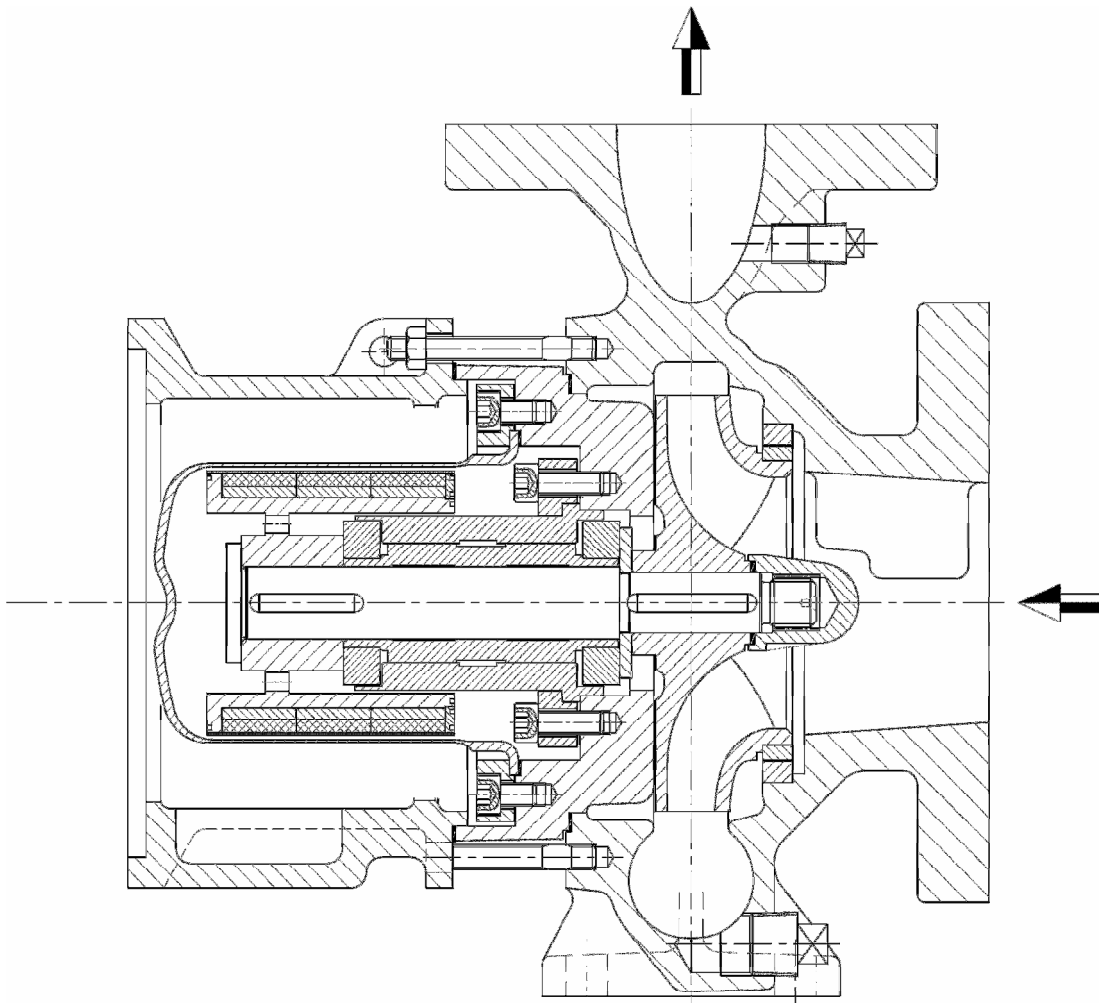

**h. Typical General Dry end assembly**

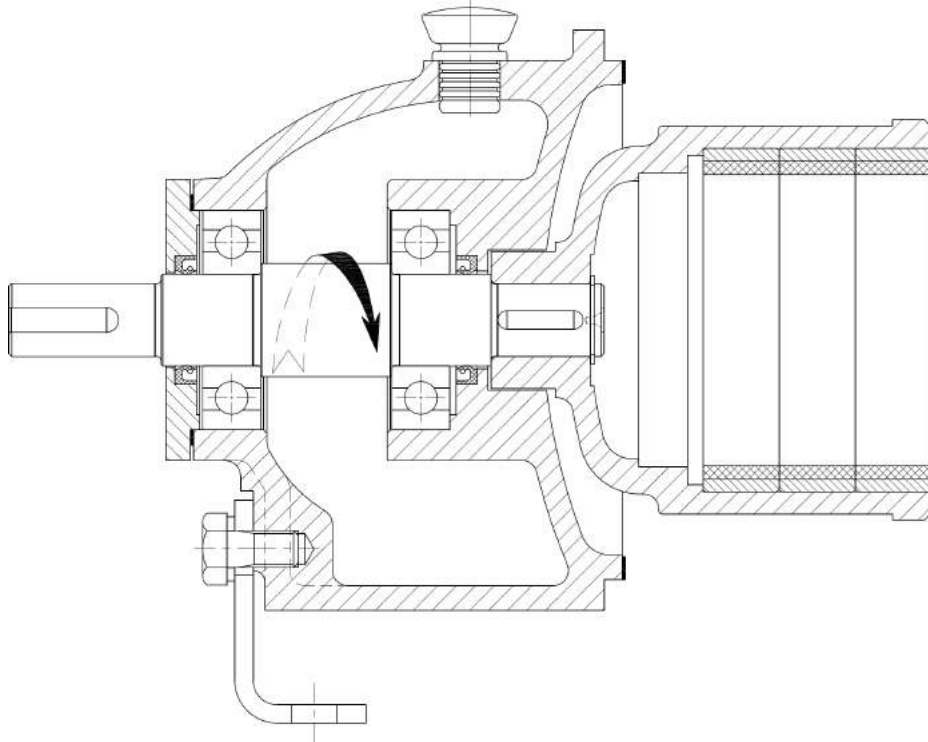



Enriching Lives

ROMAK driving unit 5 GENERAL CROSS-SECTIONAL drawing:

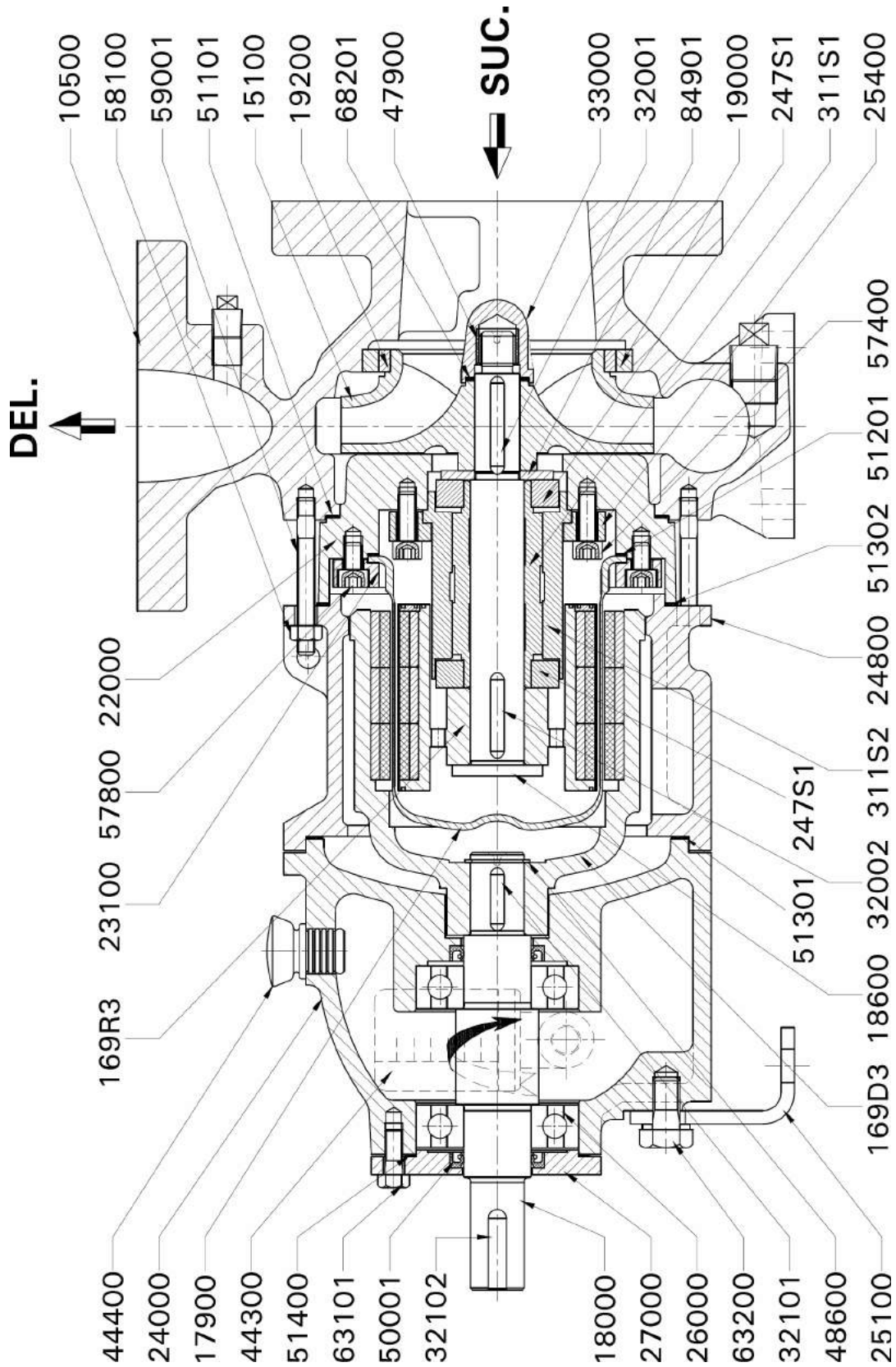



Enriching Lives

ROMAK driving unit 7 (Back vane design) GENERAL CROSS-SECTIONAL drawing:

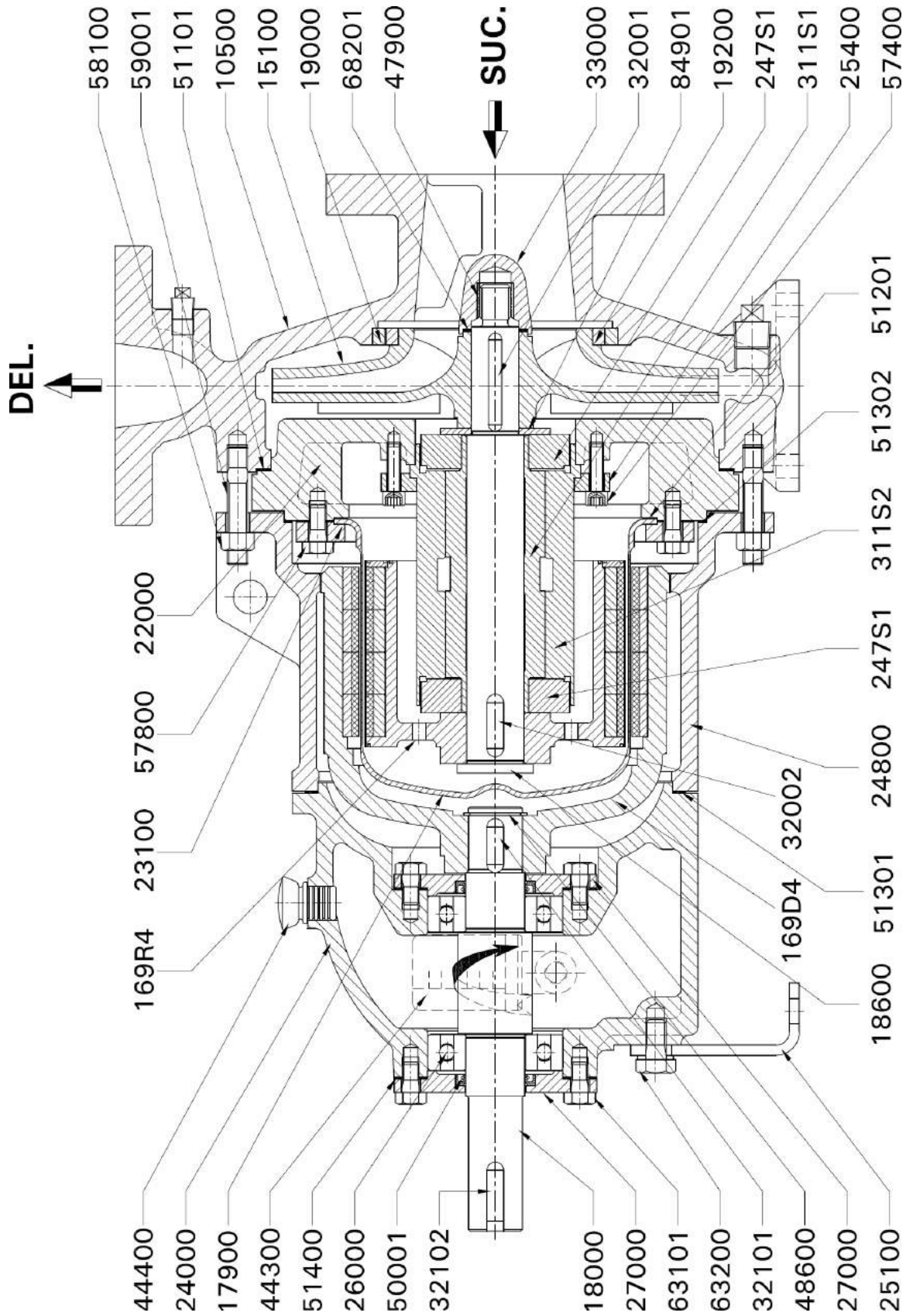



Enriching Lives

**ROMAK driving unit 7 (Back wear ring design) GENERAL CROSS-SECTIONAL drawing:**

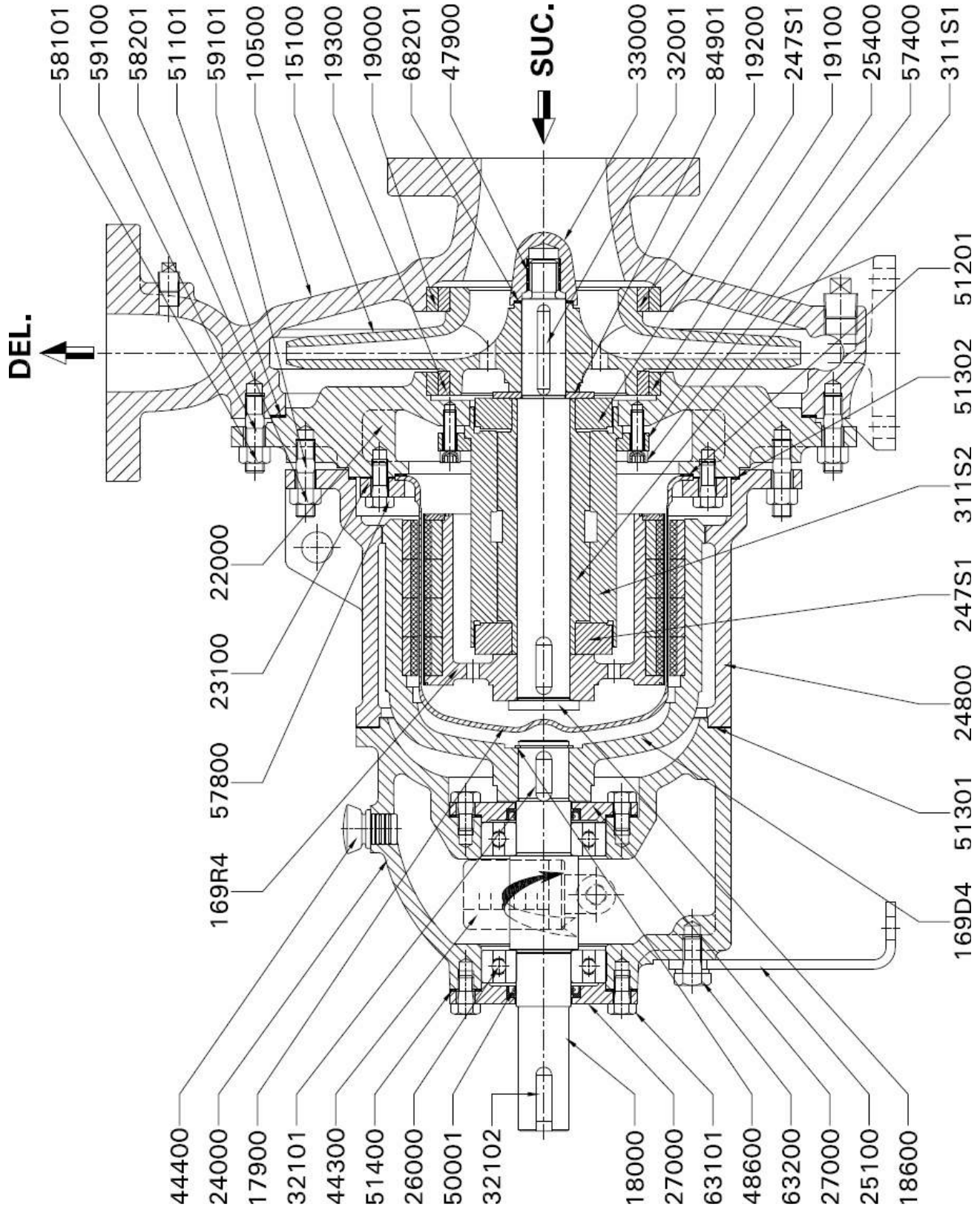



Exploded view of ROMAK driving unit 5 pump:

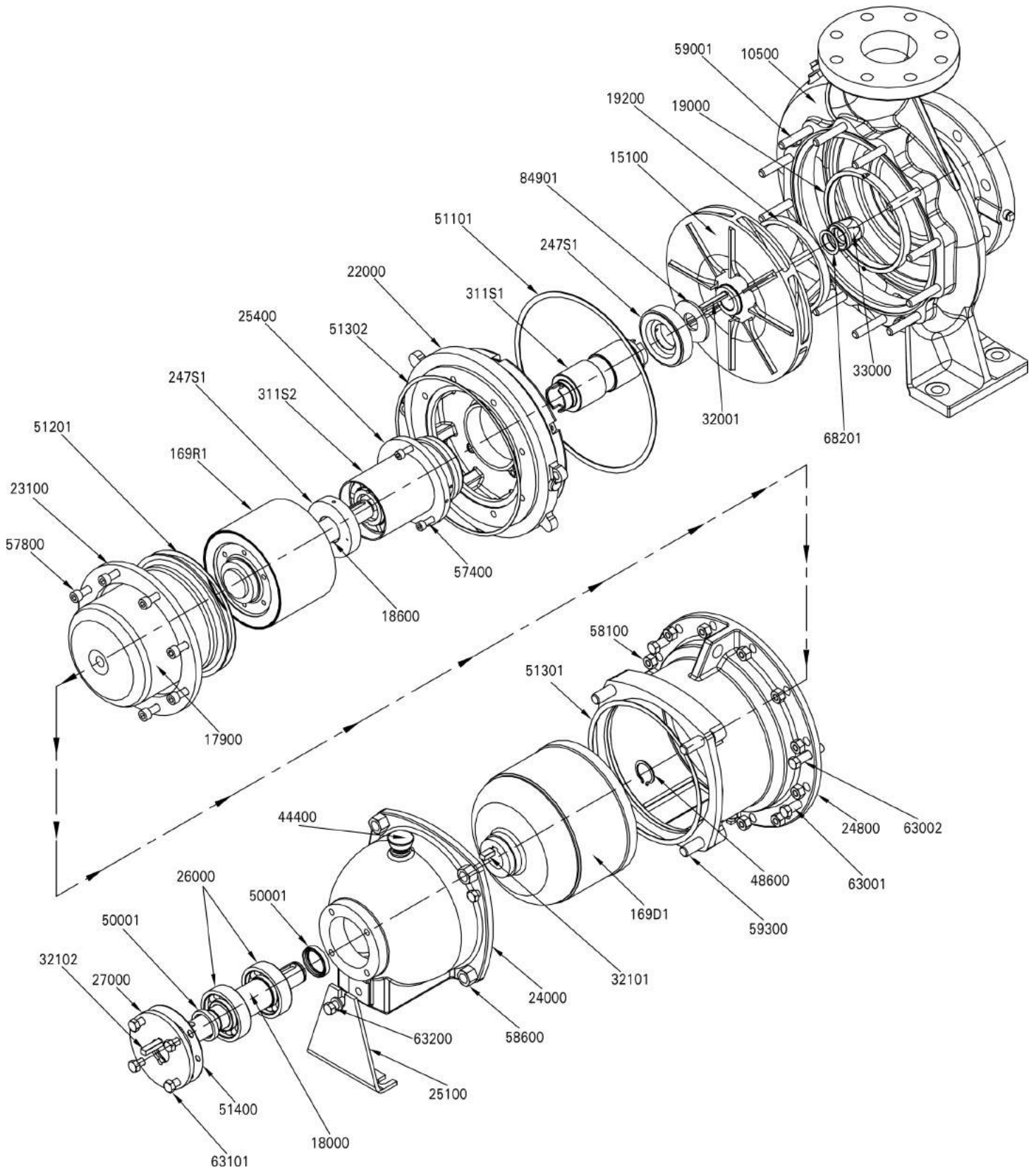

Exploded view of ROMAK driving unit 7 pump:

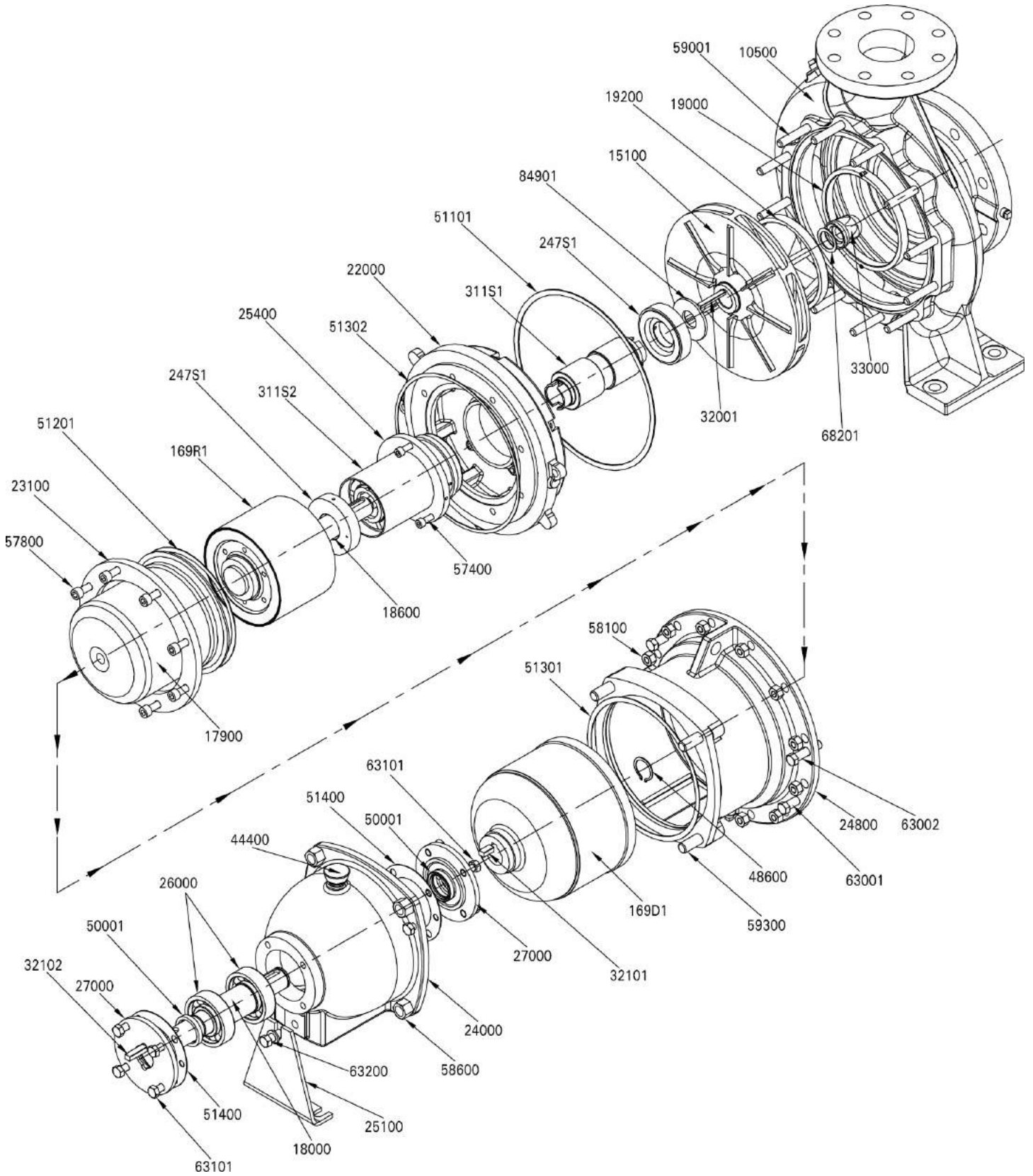

GENERAL OUTLINE DIMENSIONS:

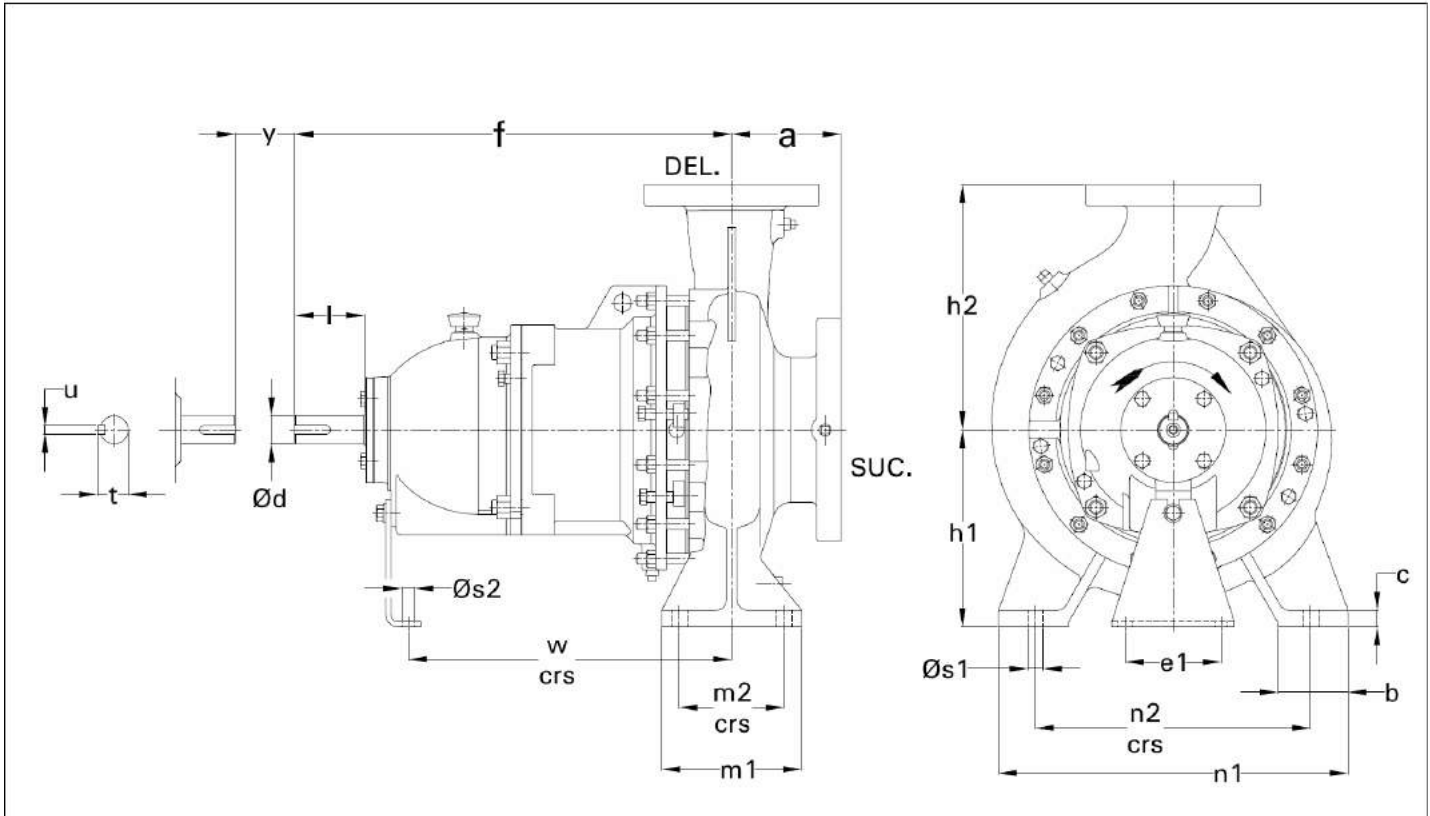

PUMP SIZE	PUMP UNIT	PUMP DIMENSIONS				FOOT DIMENSION										SHAFT END							
		DEL	SUC	a	f	h1	h2	b	c	m1	m2	n1	n2	w	Øs1	Øs2	e1	Ød	l	t	u	y	
32/13	5.1	32	50	80	385	112	140	50	14	100	70	190	140	285	14	15	110	24	50	27	8	100	
32/16,32/16A	5.2					132	160					240	190										
32/20,32/20A	5.3					160	180					265	212										
40/13	5.1	40	65	100	385	112	140	50	14	100	70	210	160	285	14	15	110	24	50	27	8	100	
40/16	5.2					132	160					240	190										
40/20,40/20A	5.3					160	180					265	212										
50/13	5.1	50	80	100	385	132	160	50	14	100	70	240	190	285	14	15	110	24	50	27	8	100	
50/16,50/16A	5.2					160	180					265	212										
50/20	5.3					160	200					265	212										
65/13	5.1	65	100	100	500	160	180	65	14	125	95	280	212	370	14	15	110	32	80	35	10	140	
32/26	7.3	32	50			180	225	65		14	125	95	320										250
40/26	7.3	40	65			200	250						65										14
50/26	7.3	50	80	180	225	65	14		125					95	320	250							
50/32	7.4			225	280			345		280													
65/16	7.1	65	100	100	500			160		200	80	16	160		120	280	212	370	14	15	110	32	80
65/20	7.2					180	225	320	250														
65/26	7.3					200	250	360	280														
80/16	7.1	80	125	125	500	180	225	80	16	160	120	320	250	370	14	15	110	32	80	35	10	140	
80/20	7.2					250	280					345	280										
80/26	7.3					225	280					400	315										
100/20	7.2	100	125	125	500	200	280	80	16	160	120	360	280	370	18	15	110	32	80	35	10	140	

NOTE: THESE ARE TENTATIVE DIMENSIONS. CERTIFIED DIMENSIONS SHALL BE SUBMITTED AGAINST ORDER.



Enriching Lives

## GENERAL INFORMATION & SAFETY INSTRUCTIONS

- 1.0 The products supplied by KBL have been designed with safety in mind. Where hazards cannot be eliminated, the risk has been minimized by the use of guards and other design features. Some hazards cannot be guarded against and the instructions below **MUST BE COMPLIED WITH** for safe operation. These instructions cannot cover all circumstances. Installation, operation and maintenance personnel must use safe working practices at all the times.
- 1.1 KBL products are designed for installation in designated areas, which are to be kept clean and free of obstructions that may restrict safe access to the controls and maintenance access points.  
A pump duty nameplate is fitted to each unit and must not be removed. Loss of this plate could make identification impossible. This in turn could affect safety and cause difficulty in obtaining spare parts. If accidental loss or damage occurs, contact KBL immediately.
- 1.2 Access to the equipment should be restricted to the person net responsible for installation, operation and maintenance and they must be trained, adequately qualified and supplied with appropriate tools for their respective tasks.
- 1.3 Most accidents involving product operation, maintenance and repair are caused by failure to observe safety rules or precautions. An accident can often be avoided by recognizing potentially situations before an accident occurs. A person must be aware of potential hazard associated in activities of installation, operation and maintenance of equipments.
- 1.4 KBL requires that, all personnel that are responsible for installation, operation or maintenance of the equipment, have access to and study the product instruction manual **BEFORE** any work is done and that they will comply with all local and industry based safety instructions and regulations.
- 1.5 Ear defenders should be worn where the specified equipment noise level exceeds locally defined safe levels. Safety glasses or goggles or face shield should be worn where working with pressurized systems and hazardous substances. Other personal protection equipment must be worn where local rules apply. Wear safety shoes, helmets and cotton overall [Apron] when you enter pump house. Noise level should not exceed 90 dbA and 110 dbA for motor driven and engine driven pumps, respectively.
- 1.6 Do not wear loose clothing or jewelry, which could catch on the controls or become trapped in the equipment.
- 1.7 Read the instruction manual before installation, operation or maintenance of the equipment. Check and confirm that you are referring relevant copy of the manual by comparing pump type on the nameplate and with that on the manual.
- 1.8 Note the "Limits of product application permissible use" specified in the manual. Operation of the equipment beyond these limits will increase the risk from hazards noted below and may lead to premature and hazardous pump failure.



Enriching Lives

- 1.9 Clear and easy access to all controls, gauges and dials etc must be maintained at all times. Hazardous or flammable materials must not be stored in pump rooms unless safe areas or racking and suitable container have been provided.
- 1.10 Use suitable earthing and tripping devices for electrical equipments.

## **2. IMPROPER INSTALLATION, OPERATION, MAINTENANCE, LUBRICATION, REPAIR OF THIS KBL PRODUCT COULD RESULT IN INJURY OR DEATH.**

If any tool, procedure, work method and operation technique is not recommended by KIRLOSKAR BROTHERS LIMITED is used or followed, it should be ensured that it is a safe for personnel around and others. It should also be ensured that the product will not be damaged or made unsafe by the operation, lubrication and maintenance or repair procedures you choose.

## **3. SAFETY INSTRUCTIONS WHILE HANDLING AND STORAGE**

When lifting the pump, use the lifting points specified on general arrangement drawing, if provided. Use lifting equipment having a safe working load rating suitable for the weight specified. Use suitable slings for lifting pump, which is not provided, with lifting points. The use of forklift truck and chain crane sling equipment is recommended but locally approved equipment of suitable rating may be used. While lifting, the equipment adjusts the center of gravity, so that it is balanced properly.

Do not place fingers or hands etc into the suction or discharge pipe outlets and do not touch the impeller, if rotated this may cause severe injury. To prevent ingress of any objects, retain the protection covers or packaging in place until removal is necessary for installation. If the packaging or suction and discharge covers are removed for inspection purposes, replace afterwards to protect the pump and maintain safety.

## **4. SAFETY INSTRUCTIONS WHILE ASSEMBLY & INSTALLATION**

Shaft alignment must be checked again after the final positioning of the pump unit and connection to pipework as this may have disturbed the pump or motor mounting positions. If hot liquids [above 80°C] are being pumped, alignment should be checked and reset with the pump and motor at their normal operating temperature. If this is not possible, KBL can supply estimated initial offset figures to suit extreme operating temperatures.

Failure to support suction and delivery pipework may result in distortion of the pump casing, with the possibility of early pump failure.

## **5. SAFETY INSTRUCTIONS WHILE COMMISSIONING & OPERATION**

Never attempt adjustments while the pump is running, unless otherwise specified in the operation, maintenance manual.

Do not touch any moving or rotating parts. Guards are provided to prevent access to these parts, where they have been removed for maintenance they must be replaced before operating the equipment.

Check that pump is primed. Pump should never be run dry as the pumped liquid acts as lubricant for the close running fits surrounding impeller and damage will be incurred.

Failure to supply the stuffing box or mechanical seal with cooling or flush water may result in damage and premature failure of the pump.



Enriching Lives

Do not touch surfaces, which during normal running will be sufficiently hot to cause injury. Note that these surfaces remain hot after the pump has stopped, allow sufficient time for cooling before maintenance. Be cautious and note that other parts of the pump may become hot if a fault is developing.

Do not operate water pumps in temperatures below freezing point, without first checking that the pumped fluid is not frozen and the pump is free to turn. Pumps in these environments should be drained down during inactivity and re-primed before starting.

In addition to local or site regulations for noise protection, KBL recommend the use of personal ear protection equipment in all enclosed pump rooms and particularly those containing diesel engines. Care must be taken to ensure that any audible alarm or warning signal can be heard with ear defenders worn.

Be aware of the hazards relating to the pump fluid, especially the danger from inhalation of noxious and toxic gases, skin and eye contact or penetration. Obtain and understand the hazardous substance data sheets relating to the pumped fluid and note the recommended emergency and first aid procedures.

## 6. SAFETY INSTRUCTIONS WHILE MAINTENANCE & SERVICING

Do not attempt repairs of the pump or its accessories which you do not know. Use proper tools.

Before attempting any maintenance on a pump particularly if it has been handling any form of hazardous liquid, it should be ensured that the unit is safe to work on. The pump must be flushed thoroughly with suitable cleaner to purge away any of the product left in the pump components.

This should be carried out by the plant operator and a certificate of cleanliness obtained before starting work. To avoid any risk to health it is also advisable to wear protective clothing as recommended by the site safety officer especially when removing old packing, which may be contaminated.

Isolate the equipment before any maintenance work is done. Switch off the main supply, remove fuses, apply lockouts where applicable and affix suitable isolation warning signs to prevent inadvertent reconnection. In order to avoid the possibility of maintenance personnel inhaling dangerous fumes or vapours locations by removal of bearing housing and shaft assembly to a suitable maintenance area.

Check and ensure that the pump operates at below the maximum working pressure specified in the manual or on the pump nameplate and before maintenance, ensure that the pump is drained down.

Wear a suitable mask or respirator when working with packing and gasket contain fibrous material, as these can be hazardous when the fibrous dust is inhaled. Be cautious, if other supplier's components have been substituted for genuine KBL parts, these may then contain hazardous materials.

Store all oily rags or other flammable material in a protective container in a safe place. Do not weld or flame cut on pipes/tubes that contains flammable fluids. Clean them thoroughly with nonflammable solvent before welding or flame cutting on them. Use solvent/chemical resistant gloves for hand protection.

**Dispose of all wastes like gaskets, gland packing, oil, batteries, packing material etc in accordance with local regulations. Normally this would involve incineration of liquid waste and controlled landfill of polymerized material.**

Adequacy of suitable crane should be checked before lifting the pump/pump components. Also condition of pulleys, chain and lifting shackles should be checked before use.

### GENERAL INSTRUCTIONS FOR INSTALLATION, OPERATION & MAINTENANCE OF KIRLOSKAR CENTRIFUGAL PUMPS

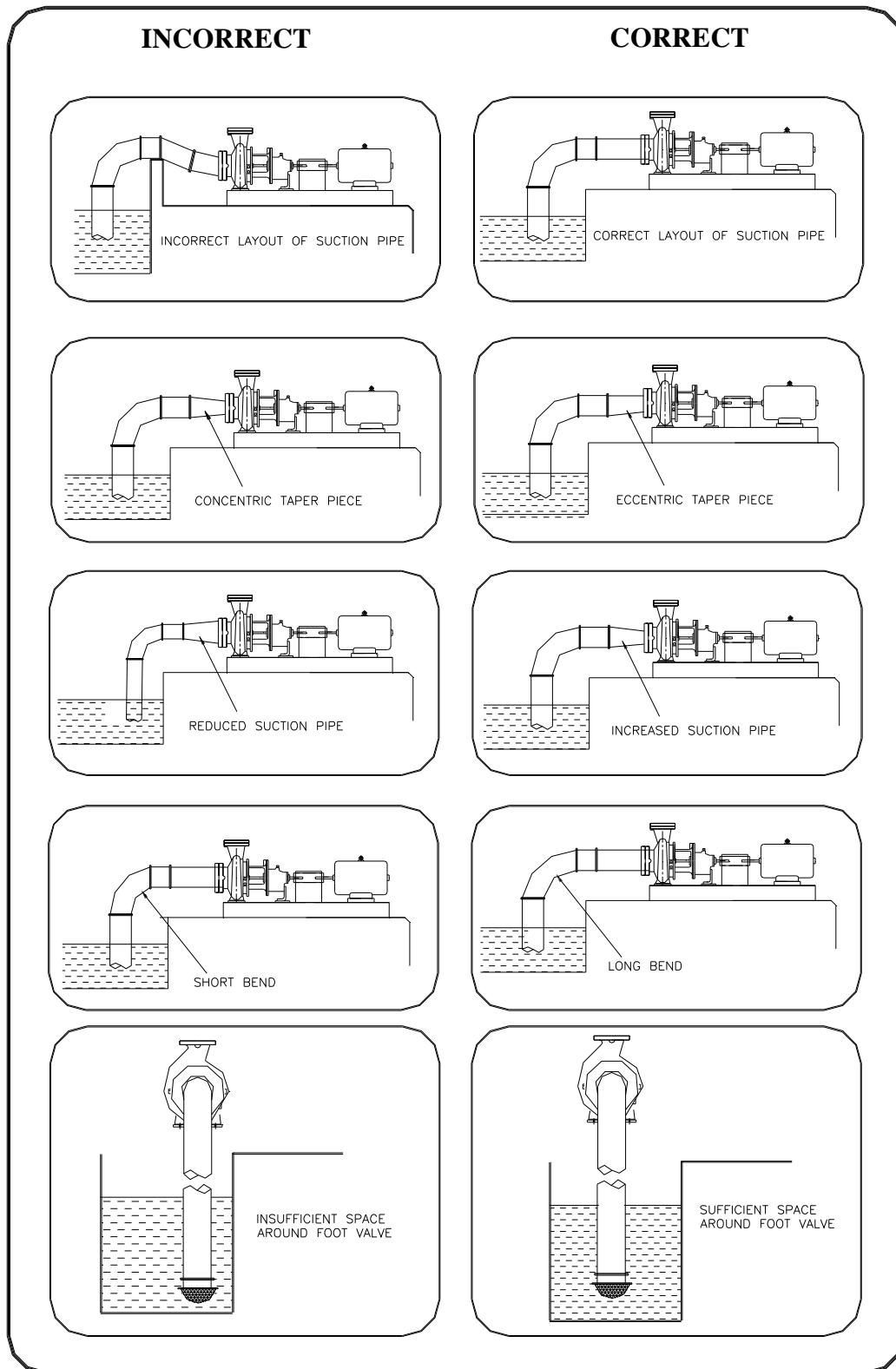



Enriching Lives

## GENERAL INSTRUCTIONS FOR INSTALLATION, OPERATION & MAINTENANCE OF KIRLOSKAR CENTRIFUGAL PUMPS

### WARNING

The equipment supplied is designed for specific capacity, speed pressure and temperature. Do not use the equipment beyond the capacities for which it is manufactured. The equipment manufactured is also shop tested for satisfactory performance and if it is operated in excess of the conditions for which it is manufactured, the equipment is subjected to excessive stresses and strains.

### LOCATION

The pump should be located as near the liquid source as possible. This will minimize suction lift and pump will give better performance.

Ample space should be provided on all the sides so that the pump can be inspected while in operation and can be serviced whenever required.

### FOUNDATION

The foundation should be sufficiently substantial to sustain any vibrations and to form a permanent rigid support for the base plate. This is important in maintaining the alignment of a directly connected unit. A concrete foundation on a solid base is advisable. Foundation bolts of the proper size should be embedded in the concrete located by a drawing or template. A pipe sleeve of two and one half diameter larger than the bolt should be used to allow movement for the final position of the foundation bolts. Earthing is required to be provided to the base plate.

### ALIGNMENT

Pumps and the drivers supplied by the manufacturers, mounted on a common base plate are accurately aligned before dispatch. However as the alignments are likely to be disturbed during transit to some extent and hence must not be relied upon to maintain the factory alignment. Re-alignment is necessary after the complete unit has been leveled on the foundation and again after the grout has been set and foundation bolts have been tightened. The alignment must be checked after the unit is piped up and re-check periodically.

### FLEXIBLE COUPLING

A flexible coupling will not compensate for the misalignment of the pump and driver shafts. The purpose of the flexible coupling is to compensate for temperature changes and to permit the movement of the shafts without interference with each other while transmitting power from the driver to the pump. There are two types of misalignments.

- 1) Angular misalignment – shaft with axis concentric, but not parallel.  
Maximum allowable misalignment is 1°

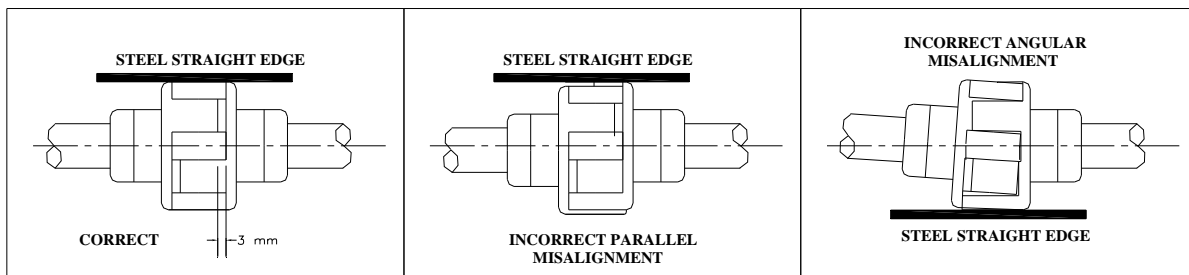

- 1) Parallel misalignment – shaft with axis parallel, but not concentric.  
Maximum allowable misalignment is 0.2 mm





Enriching Lives

### **LEVELING THE UNIT**

When the unit is received with the pump and driver mounted on the base plate, it should be placed on the foundation and the coupling halves disconnected. The coupling should not be reconnected until all misalignment operations have been completed. The base plate must be supported evenly on wedges inserted under the four corners so that it will not be distorted or sprung by the uneven distribution of the weight. Adjust the wedges until the shafts of the pump and the driver are in level. Check the coupling faces, suction and discharge flanges for the horizontal and vertical position by means of spirit level.

### **FLEXIBLE COUPLING ALIGNMENT**

The two halves of the coupling should be at least 3 mm apart so that they cannot touch each other when the driver shaft is rotated. Necessary tools for approximately checking are straight edge or an outside caliper. A check for parallel misalignment is made by placing a straight edge across both coupling periphery at the top, bottom and both the sides. The unit will be in parallel alignment when the straight edge rests evenly on the coupling periphery at all the positions. Care must be taken that the straight edge must be parallel to the axis of the shaft.

### **GROUTING**

When the alignment is correct, the foundation bolts should be tightened evenly but not too firmly. The unit can then be grouted by working soft concrete under the edges. Foundation bolts should not be fully tightened until the grout is hardened, usually 48 hours after pouring.

### **FACTORS THAT MAY DISTURB ALIGNMENT**

The unit should be periodically checked for alignment. If the unit does not stay in line after being properly installed, the following are possible causes:

1. Setting, seasoning of the foundation.
2. Pipe strains distorting or shifting the machines.
3. Wear of the bearing.

### **PIPING**

Both suction and delivery pipes and accessories should be independently supported near the pump, so that when the flanges, bolts are tightened no strains will be transmitted to the pump casing. It is usually advisable to increase the size of both the suction and delivery pipe at the pump nozzles in order to decrease the loss of head due to friction and for the same reason piping should be arranged with minimum possible bends as possible, or it should be made with long radius wherever possible. The pipe lines should be free from scales, welding residuals etc., and have to be mounted in such a way that they can be connected to suction and delivery flanges without any stress on the pump. It can be achieved by supporting the pipelines at appropriate locations.

### **SUCTION PIPE**

The suction pipe should be as short as possible. This can be achieved by placing the pump near the liquid to be pumped. The suction pipe must be kept free from air leakages. This is particularly important when the suction lift is high. A horizontal suction line must have a gradual rise to the pump. Any high point in the pipe will be filled with air and thus prevent proper operation of the pocket in the top of the reducer and the pipe. Use an eccentric piece instead.

The end of the suction pipe must be well submerged to avoid whirlpools and ingress of air but must be kept clear of any deposits of mud, silt grit etc. The pipe must be away from any side of the wall by 450 mm. the end of the strainer must be provided with a strainer of sufficient open area.



Enriching Lives

### **DELIVERY PIPE**

A check (non return) valve and a gate or sluice valve (regulating valve) should be installed in the discharge line. The check valve placed between the pump and the gate valve is to protect the pump from excessive pressure and to prevent water running back through the pump in case of failure of the driving machine.

Discharge piping should be provided with a sluice valve adjacent to the delivery flange to control the discharge if required.

### **VACUUM EQUALIZING LINE (AND LIQUID LINE)**

If the pump draws from a system under vacuum an equalizing pipe must be carried from the highest point of the suction line, however as close to the suction flange of the pump as possible, to the top of the feed tank to keep gas bubbles that might have been entrapped in the flow from entering the pump. The line should be fitted with an isolating valve which should be closed only for maintenance work on the pumpset.

Apply sealing liquid (external sealing) to the shaft seal cage to prevent entry of air in the case of the pumps with packed stuffing box. It is convenient to tap the sealing liquid from the delivery line above the non-return valve.

### **FOOT-VALVE**

It is advisable to install a foot-valve to facilitate priming. The foot-valve should have sufficient clear passage for water. Care must be taken to prevent foreign matter from being drawn in to the pump or choking the foot-valve and for this purpose an efficient strainer should be provided.

### **STUFFING BOXES AND PACKING (only for gland packed pump)**

Stuffing boxes should be carefully cleaned and packing placed in them. Be sure that sufficient packing is placed at the back of the water seal cage. If the water to be pumped is dirty or gritty, sealing water should be piped to the stuffing boxes from clean outside source of supply in order to prevent damage to the packing and shaft. In placing the packing, each packing ring should be cut to the proper length so that ends come together but don't overlap. The succeeding rings of packing should not be pressed too tight, as it may result in burning the packing and cutting the shaft. If the stuffing box is not properly packed, friction in stuffing box prevents turning the rotor by hand. On starting the pump it is well to have the packing slightly loose without causing an air leak, and if it seems to leak, instead of putting too much pressure on the gland, put some heavy oil in the stuffing box until the pump works properly and then gradually tighten up the gland. The packing should be occasionally changed.

### **BALL BEARINGS**

Correct maintenance of ball bearings is essential. The bearing manufacturers give the following as a guide to re-lubrication periods under normal condition for Grease lubricated bearings.

Three monthly when on continuous duty.

Six monthly when on eight hour per day duty.

The bearings and housings should be completely cleaned and recharged with fresh grease after 2500 hrs. or the nearest pump overhaul time.

### **PRIMING**

No pumping action occurs unless the pump casing is filled with the liquid. Pump casing and suction pipe must therefore be completely filled with liquid and thus all air removed before the pump is started. Several different priming methods can be used depending on the kind of installation and service involved.

- 1) Liquid level above pump level.



Enriching Lives

- Pump is set below liquid level of source of supply, so that liquid always flows to pump under positive head.
- 2) Priming with foot-valve.
    - a. When pump is installed on suction lift with foot valve at the end of suction line, fill pump with water from some outside source till all air is expelled and water flows through the air vent.
    - b. When there is liquid under some pressure in the discharge pipe, priming can be effected by bypassing the pressured liquid around the check and gate valve. Of course, the initial priming must be effected from some outside source.

**Note:** In this case, the foot-valve must be capable of withstanding pump pressure and possible surge.
  - 3) Priming by ejector  
An ejector operated by steam, compressed air or water under pressure and connected to air vent at the top of casing can be used to remove air from pump and prime the pump on suction lift installations.
  - 4) Priming by dry vacuum pump  
A hand or power pump sucks in all the air from the casing and the suction pipe, and thus primes the system.

### **STARTING**

The pump must not be started without being primed. Be sure that the driver rotates in the proper direction as indicated by a direction arrow on the pump casing.

### **RUNNING**

On account of its simple construction, the centrifugal pump requires practically no attention while running. Lubrication at the bearings and manipulation of the glands are the only things that need attention from the operator.

### **STOPPING**

Before stopping the pump; close the gate valve. This will prevent water hammer on the check valve.

### **STUFFING BOXES (only for gland packed pump)**

Do not tighten the glands excessively. A slight dripping of water from the stuffing boxes when pump is running keeps packing in good condition.

### **CASING RINGS**

Casing rings are fitted in the casing to reduce the quantity of water leaking back from the high pressure side to the suction side. These casing rings are fitted to maintain a small clearance and depend on the water in the pump for lubrication. When the rings are worn out, the clearance becomes greater and more water passes back into the suction side. The rings must be replaced from time to time to restore the pump efficiency to its normal value.

### **SPARE PARTS**

A set of ball bearings, a set of casing rings and a set of gland packing rings / mechanical seal must always be kept at hand to ensure uninterrupted service from the pump. While ordering for spare parts, always give type, size and serial number of the pump as stamped on the number plate.

### **PUMP TROUBLE**

When investigating trouble with Kirloskar pumps, always remember that pumps have been tested at the factory and are mechanically correct when sent out. Discounting the possibility of damage during transit, most of the trouble in the field is due to faulty



Enriching Lives

installation. Investigation shows that the majority of troubles with centrifugal pumps result from faulty conditions on the suction side.

### BREAK DOWN-CAUSE-CHECK POINTS

In case of breakdown we recommend the location of the fault by using the following table. In any below case, pump should be stopped immediately otherwise it will lead to heavy loss of product, components, production and can extent to personal injuries.

### BREAKDOWN CHECK POINTS

Pump does not deliver	1 7 8 9 10 11 12 14 15 17 18 19 26 50 51 52 57 58
Pump delivers at reduced capacity	1 2 3 4 5 6 7 8 9 10 11 12 13 14 15 17 18 19 20 21 22 50 51 52
Delivery performance deteriorates	1 3 7 9 10 11 12 13 14 19 20 21 22 47 51 56
Pump delivers too much	16 50 51 52
Delivery is interrupted	1 3 6 7 8 9 10 11 12 13 14 15 16 19 22 26 50 51 52 56 58
After stopping pump runs in reverse direction	46
Very noisy	1 2 5 6 7 8 11 12 13 15 19 20 22 26 48 49 50 51 56
Unsteady running of pump	19 20 22 26 27 29 31 32 33 34 35 36 37 38 41 42 43 44 45 48 49 52
Lantern bracket leakage	59
Pump rotor locked in standstill position	22 24 25 26 39 40 44
Pump is heating up and seizing	23 24 25 26 27 29 30 36 39 41 42 43 44 48 58
Ball Bearing temperature increases	19 20 21 22 27 28 29 30 31 32 33 34 35 36 37 38 39 40 41 42 43 45 48 49 52
Motor not starting	54
Motor gets hot or burns out	14 22 23 24 25 26 27 36 37 44 49 50 51 52 53 54 55
Motor is difficult to start	14 22 27 39 40 44 52 53 54

### CHECK POINTS

1. Suction pipe, foot valve choked.
2. Nominal diameter of suction line too small.
3. Suction pipe not sufficiently submerged.
4. Too many bends in the suction line.
5. Clearance around suction inlet not sufficient.
6. Shut off valve in the suction line in unfavorable position.
7. Incorrect layout of suction line (formation of air pockets).
8. Valve in the suction line not fully open.



Enriching Lives

9. Joints in the suction line not leak-proof.
10. Air leaking through the suction line, Can gasket etc.
11. Suction lift too high.
12. Suction head too low (difference between pressure at suction connection and vapor pressure too low).
13. Delivery liquid contains too much gas and/or air.
14. Delivery liquid too viscous.
15. Insufficient venting.
16. Number of revolutions too high.
17. Number of revolutions too low.
18. Incorrect direction of rotation (electric motor incorrectly connected, leads of phases on the terminal block interchanged).
19. Impeller clogged.
20. Impeller damaged.
21. Casing rings worn out.
22. Separation of crystals from the flow of pumping liquid (falling below the temperature limit/equilibrium temp).
23. Lubricating liquid line obstructed.
24. Lubricating liquid contaminated.
25. Lubricating liquid omitted.
26. Plain SSiC Bearings got damaged or worn out.
27. Ball Bearing worn out.
28. Specified oil level not maintained.
29. Insufficient lubrication of bearings.
30. Ball bearings over-lubricated.
31. Oil quality unsuitable.
32. Ball bearing incorrectly fitted.
33. Axial stress on ball bearings.
34. Ball Bearings dirty.
35. Ball Bearings rusty (corroded).
36. Axial thrust too great because of worn casing rings.
37. Alignment of coupling faulty or coupling loose.
38. Elastic element of coupling worn.
39. Pump casing under stress.
40. Pipeline under stress.
41. Shaft runs untrue.
42. Shaft bent.
43. Rotor parts insufficiently balanced.
44. Rotor parts touching to the Casing, Can
45. Vibration of pipe work.
46. Non-return valve gets caught.
47. Contaminated delivery liquid.
48. Obstruction in delivery line.
49. Delivery flow too great.
50. Pump unsuitable for parallel operation.
51. Type of pump unsuitable.
52. Incorrect choice of pump for existing operating conditions.
53. Voltage too low/power supply overloaded.
54. Short circuit in the motor.
55. Setting of starter of motor too high.
56. Temperature of delivery liquid too high.
57. Motor starting torque too high.
58. Magnet decoupled.
59. Can holding screws gets loose.



Enriching Lives

## KIRLOSKAR BROTHERS LIMITED

A Kirloskar Group Company  
Established 1888

### GLOBAL HEADQUARTERS

“Yamuna”, S. No. 98/3 to 7, Baner, Pune - 411045, India  
Phone: +91-20-27214444 Email: kblin@kbl.co.in

### REGISTERED OFFICE

Udyog Bhavan, Tilak Road, Pune - 411002, India  
Phone: +91-20-24440156 Fax: +91-24440156

### GLOBAL PRESENCE

Cambodia | Egypt | India | Lao PDR | Senegal | South Africa | Thailand | The Netherlands  
| United Arab Emirates | United Kingdom | United States of America | Vietnam

[www.kirloskarpumps.com](http://www.kirloskarpumps.com)

### OUR COMPANIES



United Kingdom



U.S.A.



South Africa



India



The Netherlands